

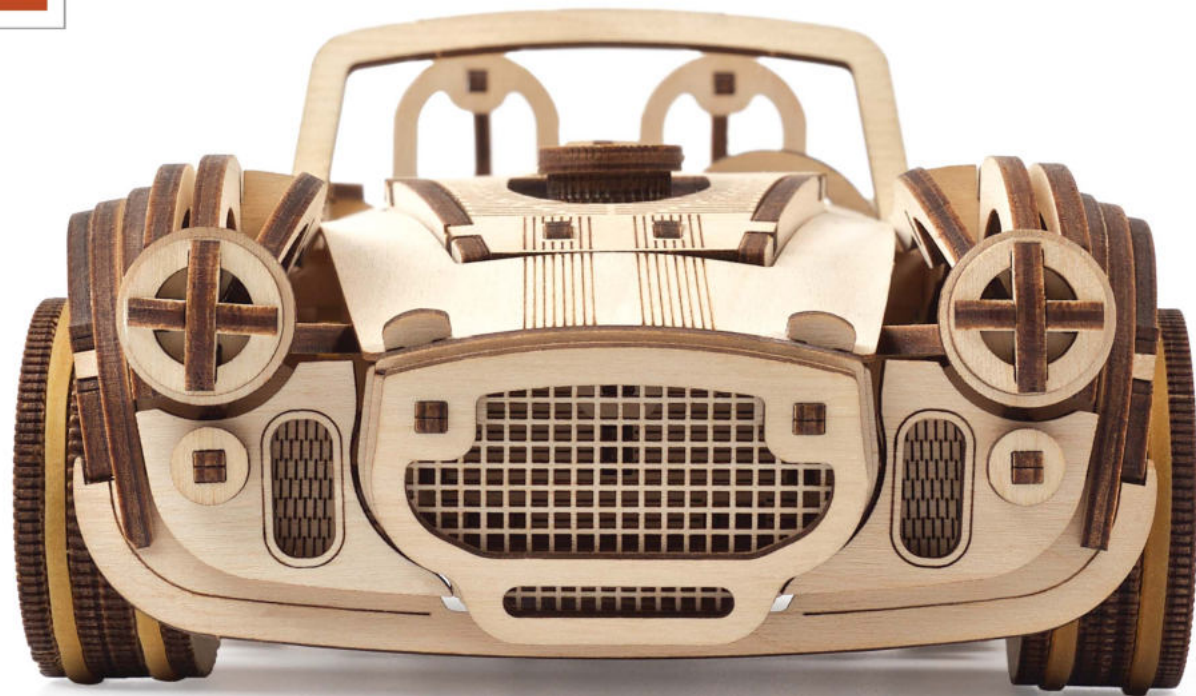

Find out MORE

Assemble Me.
Burn tires!



UGEAR'S®

Mechanical models

Model Drift Cobra Racing Car Модель Дрифт Кобра Гоночный автомобиль

FRA Modèle Modèle Voiture de course Cobra Drift

DEU Modell Cobra Drift Rennwagen

SPA Modelo Coche deportivo Cobra Drift

ITA Modello Macchina da corsa Drift Cobra

JPN モデル ドリフトコブラレーシングカー

CHI 模型 漂移眼镜蛇赛车

RUS Модель Дрифт Кобра Гоночный автомобиль

POL Model Wścigowy samochód Drift Cobra

KOR 모델 코브라 드리프트 레이싱카

FRA Notice d'assemblage. DEU Aufbauanleitung.

SPA Instrucciones de montaje. ITA Istruzioni di montaggio.

JPN 組み立て説明書 CHI 装配说明书 RUS Инструкция по сборке.

POL Instrukcja montażu. KOR 조립 설명서.



MECHANICAL
МЕХАНІЧНІ



NO GLUE CONNECTION
БЕЗ КЛЕЮ



PLYWOOD
З ФАНЕРИ

ENG

Assembly instructions:
Remove model parts from the hanger board as illustrated below. Careful not to break parts. If a part does not remove easily, carefully cut it out with a knife. This model is intended for self-assembly without glue. If you have difficulty installing the axles, try waxing them with a regular candle. All moving parts can also be waxed during assembly to reduce friction when operating the model.

CHI

装配说明
将模型部件按插图示，从胶合板取下。小心不要损坏件。如果取下时候有难度，请用小刀小心的切割连接点。这个产品不需要胶水粘接。如果安装转轴的时候有难度，请用普通的蜡加以润滑。所有的转动部分也需要打蜡润滑。

UKR

Інструкція зі складання:
Витягніть з дошки позначені на схемі деталі. Намагайтеся їх не зламати. Якщо деталь не виймається, надсічіть перемички ножом. Конструкція збирається без клею. У разі виникнення труднощів з протягуванням вісі в отвір, потріть деталь об звичайну свічку. Також можна змастити свічкою всі деталі механізму, що рухаються, щоб зменшити тертя при обертанні.

RUS

Инструкция по сборке:
Вынимайте из доски обозначенные на схеме детали. Старайтесь их не сломать. Если деталь не извлекается, надрежьте перемычки ножом. Конструкция собирается без клея. Если возникли трудности с установкой деревянной оси, перед установкой потрите детали об обычную свечу. Для лучшего скольжения смазывайте движущиеся детали механизма обычной свечой во время сборки.

FRA

Notice d'assemblage:
Faites sortir de la planche les pièces comme indiquées sur le schéma. Tâchez de ne pas les casser. Si la pièce ne sort pas, incisez les collages/fixations avec un couteau. La construction est à assembler sans colle. Si il est difficile d'introduire l'axe en bois dans l'orifice, frottez de préalable l'axe ou les pièces contre une bougie. Pour améliorer le glissement, traitez les pièces de frottement mobiles du mécanisme avec une bougie au cours d'assemblage.

POL

Instrukcja montażu:
Delikatnie wyciągaj z deseczki wskazane w schemacie detale, starając się nie potać elementów. Jeśli detal nie poddaje się, podetnij wiązadła nożem. Konstrukcje składa się bez kleju. Jeśli napotkasz trudności z instalacją drewnianej osi w otwór, potrzyj na początku oś lub detale o woskową świecę. Dla lepszego poślizgu polecano smarowanie ruchomych części mechanizmu zwykłą świecą podczas montażu.

DEU

Aufbauanleitung:
Bitte die in der Zeichnung angegebenen Teile aus der Platte herausnehmen. Versuchen Sie bitte diese nicht zu brechen. Wenn sich ein Teil nicht herausnehmen lässt, schneiden Sie die Stege mit dem Messer leicht an. Das Modell wird ohne Klebstoffe zusammgebaut. Lässt sich eine Achse nur schwer in eine Öffnung einführen, reiben Sie diese mit einer Kerze etwas ein. Für besseres Gleiten schmieren Sie alle beweglichen Teile mit einer Kerze.

KOR

조립 설명:
부품이 손상되지 않도록 주의하여 보드에서 떼어냅니다. 만약 부품이 잘 떨어지지 않으면 연결 부분을 칼로 절단 한 후 떼어내면 쉽게 떼어 낼 수 있습니다. 본 제품은 접착제가 없이 조립이 가능하도록 설계되어 있습니다. 만약 축이 잘 끼워지지 않는 경우 양초를 축에 바른 후 끼워 보세요. 모든 구동 부위는 제품 구동 시 원활한 작동이 가능하도록 조립 과정에서 윤활제(양초)양초를 발라 주세요.

SPA

Instrucciones de montaje:
Saque de la tabla las piezas marcadas en el esquema. Trate de no romperlas. Si una pieza no se saca, haga una incisión. La construcción va sin pegamento. Si tiene dificultades con la instalación del eje de madera en un agujero, frote primero el eje o las piezas contra una vela. Para un mejor deslizamiento, lubrique durante el montaje las piezas móviles del mecanismo con una vela común.

ITA

Istruzioni di montaggio:
Estrarre dal telaio i particolari indicati nello schema. Fare attenzione a non romperli. Se un particolare non si stacca, tagliare delicatamente gli elementi di collegamento con un coltello. L'assieme viene realizzato senza colla. In caso di difficoltà nell'inserimento di un perno in legno, è necessario sfregare il perno o il particolare con un po' di cera. Per uno scorrimento migliore incerare le parti mobili del meccanismo durante l'assemblaggio.

JPN

組み立て説明書:
部品に傷をつけないように注意しながらボードから外してください。部品が外れにくい場合は連結部分をカッターで切ってから外すと外しやすいです。本製品は、接着剤がなくても組み立てができるように設計されています。もしアクスル(駆動部)が、歯車の動きがにぶい場合は、口ウソクをアクスルに塗ってください。全ての駆動部分は製品を動かす時、滑らかに動くように潤滑剤である口ウソクを塗りながら組み立てます。

ENG Warning! UKR Увага! FRA Attention! DEU Achtung! SPA Precaución! ITA Attenzione! JPN 注意! CHI 注意! RUS Внимание! POL Uwaga! KOR 주의!



ENG Do not use a lighted candle! **UKR** Не підпалювати!
FRA Ne pas brûler! **DEU** Nicht anzünden!
SPA ¡No encender! **ITA** Non dare fuoco!
JPN 火のついた口ウソクの使用はお止めください。
CHI 请勿点燃，请勿靠近火源！ **RUS** Не поджигать!
POL Nie podpalać! **KOR** 불이 붙은 초를 이용하지 마세요!



ENG Caution! Axles have sharp points! **UKR** Обережно! Гострі деталі!
FRA Attention: certaines pièces sont pointues! **DEU** Vorsicht! Spitze Teile!
SPA ¡Atención! Piezas afiladas! **ITA** Attenzione! Particolari appuntiti!
JPN アクスル(駆動部)の鋭い部分にご注意ください。 **CHI** 舍尖锐部件!
RUS Осторожно! Острые детали! **POL** Ostrożnie! Ostre części!
KOR 축의 뾰족한 부분에 주의하세요! 注意!



ENG Wax the part with a regular candle (rub with a candle). **UKR** Змастіть деталь звичайною свічкою (потріть об свічку). **FRA** Lubrifiez la pièce avec une bougie ordinaire (frottez contre la bougie). **DEU** Reiben Sie das Teil mit einer einfachen Kerze etwas ein. **SPA** Engrasa la pieza con una vela común (frote con una vela). **ITA** Incerare il componente (Sfregare con la cera). **JPN** された部分に潤滑油としてろうソックスを塗ってください。 **CHI** 用普通蜡烛涂沫润滑部件 **RUS** Смажьте деталь обычной свечкой (потрите о свечку). **POL** Przesmaruj zwykłą świecą. **KOR** 표시된 부분에 윤활을 위해 촛을 칠해 주세요.



ENG Sand to remove burrs. **UKR** Видаліть задирки. **FRA** Éliminez les bavures. **DEU** Grate entfernen. **SPA** Quite las rebabas. **ITA** Togliere le bave. **JPN** バリ取りのサンドペーパー **CHI** 磨掉毛刺 **RUS** Удалите заусенцы. **POL** Usuń zadziorły. **KOR** 거친 부분을 다듬어 주세요.



ENG Pay attention. Check position of the part. **UKR** Зверніть увагу. Перевірте розташування елемента. **FRA** Faites attention. Vérifiez la disposition de l'élément. **DEU** Bitte Beachten. Prüfen Sie die Einbaulage des Elements. **SPA** Atención. Compruebe la situación del elemento. **ITA** Prestare attenzione. Controllare la posizione del componente. **JPN** 方向及び位置に注意して組み立ててください。 **CHI** 注意! 检查部件方向和位置 **RUS** Обратите внимание. Проверьте расположение элемента. **POL** Zwróć uwagę. Sprawdź lokalizację elementu. **KOR** 방향 또는 위치에 주의해서 조립해 주세요.



ENG Check the mechanism for smoothness and accuracy of movement. Operate the mechanism so the part would seat in. **UKR** Переверте механізм на плавність і точність ходу. Розробіть механізм. **FRA** Vérifiez si le mécanisme fonctionne en douceur et avec précision. Faites fonctionner le mécanisme jusqu'à son fonctionnement normal. **DEU** Prüfen Sie den Mechanismus bezüglich der Laufruhe und der Genauigkeit des Ganges. Betätigen Sie den Mechanismus mehrmals. **SPA** Verifique la suavidad y precisión del mecanismo. Desarrolle el mecanismo. **ITA** Controllare la scorrevolezza e la precisione del movimento. Far funzionare il meccanismo. **JPN** 駆動部分が滑らかに動くかを確認しながら作業をすすめます。 **CHI** 检查机构的运行平稳度和精确度。请整机构。 **RUS** Проверьте механизм на плавность и точность хода. Разработайте механизм. **POL** Sprawdź płynność i dokładność ruchu mechanizmu. Dopracuj mechanizm. **KOR** 구동 부분의 원활한 작동과 정확한 움직임을 확인하세요.



ENG Do not fully press the outer parts (structural frame) together until checking for fit and alignment of internal parts. **UKR** Дев'ять час не притискайте сильно деталі (рамки конструкції). **FRA** Ne pas forcer sur les pièces (cadre de la construction). **DEU** Drücken Sie die Teile (die Rahmen der Konstruktion) momentan nicht stark. **SPA** No presione temporalmente con fuerza las piezas (marco de la estructura). **ITA** Non stringere provvisoriamente i componenti con forza (base della costruzione). **JPN** 内部部品がしっかりと組み立てられる前に外部部品は強く押しながら固定してはいけません。 **CHI** 在检查内部零件的配合和对准之前, 请暂时不要将外部零件 (结构框架) 完全压在一起。 **RUS** Временно сильно не прижимайте детали (рамки конструкции). **POL** Tymczasowo nie dościsłaj elementów (ramy konstrukcji). **KOR** 아직은 외부의 틀을 완전히 눌러서 고정하면 안 됩니다. 다른 부품을 먼저 끼우세요.



ENG Press the parts as far as they will go. **UKR** Притисніть деталі до упору. **FRA** Pressez les pièces à fond. **DEU** Drücken Sie die Teile bis zum Anschlag. **SPA** Pulse para detener las piezas. **ITA** Stringere bene i componenti. **JPN** 部品をできる限り押しつけてください。 **CHI** 用力紧密结合部件 **RUS** Прижмите детали до упора. **POL** Przycisnąć element, aż do oporu. **KOR** 부품을 양쪽에서 눌러서 고정해 주세요.



ENG The part should be easily rotated (moved). **UKR** Деталь повинна легко крутяться (рукатися). **FRA** La pièce doit tourner (se déplacer) aisément. **DEU** Der Teil soll leicht gedreht (bewegt) werden. **SPA** La pieza debe ser fácil de girar (mover). **ITA** Il componente deve girare (muoversi) facilmente. **JPN** 部品はしっかりと動かなければなりません。 **CHI** 此部件必须容易的旋转 (移动) **POL** Element powinien łatwo się kręcić (poruszać się). **RUS** Деталь должна легко крутиться (двигаться). **KOR** 알맞게 움직일 수 있어야 합니다.



ENG Break off or cut out. **UKR** Відламайте або відріжте. **FRA** Coupez ou cassez. **DEU** Abbrechen oder Abschneiden. **SPA** Rompa o corte. **ITA** Staccare o tagliare. **JPN** 切ってください。 **CHI** 切断 **RUS** Отломайте или отрежьте. **POL** Odłam lub odetnij. **KOR** 잘라내 주세요.



+ **ENG** Specified details come with spare duplicates. **UKR** Зазначені деталі є на дошках як запасні. **FRA** Les détails spécifiés sont fournis avec des doublons de rechange. **DEU** Die angegebenen Details werden mit Ersatzduplikaten geliefert. **SPA** Los detalles especificados vienen con duplicados de repuesto. **ITA** I dettagli specificati vengono forniti con duplicati di riserva. **JPN** 指定された詳細には予備の複製が付属しています。 **CHI** 指定的細節帶有備用副本。 **RUS** Указанные детали поставляются с запасными дубликатами. **POL** Zapasowe elementy są zaznaczone na desce. **KOR** 명시된 세부 사항은 여분의 복사본과 함께 제공됩니다.

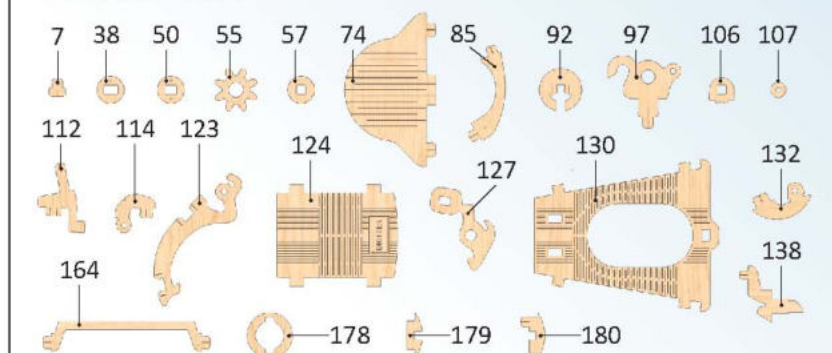

ENG This is not a structural component; it is a tool for measurement and assembly. **UKR** Це не деталь конструкції, а допоміжний інструмент для складання або вимірювання відстаней. **FRA** Cette pièce ne fait pas partie de la construction mais constitue un outil annexe pour l'assemblage ou la mesure des distances. **DEU** Es ist kein Teil der Konstruktion, sondern ein Hilfselement für den Zusammenbau oder für das Messen der Abstände. **SPA** No es una pieza de la construcción sino un instrumento auxiliar para montar o para medir distancias. **ITA** Non è un componente del modello, ma un'attrezzatura aggiuntiva per il montaggio o il rilievo delle quote. **JPN** この部品は完成時の部品ではなく、組み立てをサポートしたり測定する道具です。 **CHI** 这不是装配零部件, 是一种测量及安装辅助工具。 **RUS** Это не деталь конструкции, а вспомогательный инструмент для сборки или измерения расстояний. **POL** To nie detal konstrukcji, a pomocnicze narzędzie dla montażu i wymiaru odległości. **KOR** 이 부품은 조립을 위한 부품이 아니고 조립을 돕거나 측정을 위한 도구입니다.

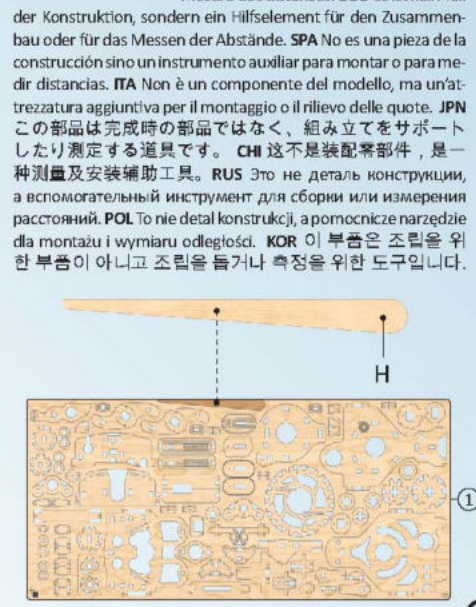

Mechanical models

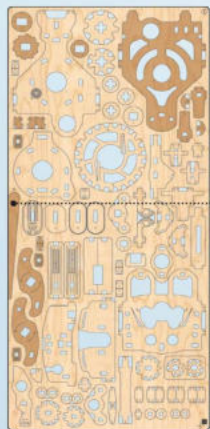

ENG It's easier to pull out some parts with the «helper (H)». UKR Буде легше видавити готові деталі за допомогою «helper (H)». FRA Il est plus facile de retirer certaines pièces avec la pièce-outils (H). DEU Es ist einfacher, einige Teile mit dem "Helper (H)" herauszunehmen. Siehe Beispiel: SPA Para separar algunas partes resulta más fácil utilizando la ayuda del elemento "H". ITA È più facile estrarre alcuni elementi utilizzando l'«aiuto (H)». JPN ある部品は「helper (H)」を使うと取り外しやすいです。CHI 使用「helper (H)」可以更容易地拉出某些零件。RUS Будет легче выдавить готовые детали с помощью «helper (H)». POL Niektóre części łatwiej jest wyciągnąć za pomocą «pomocnika (H)». KOR 일부 부품은 'H' 도구를 이용하여 떼어내면 쉽습니다.

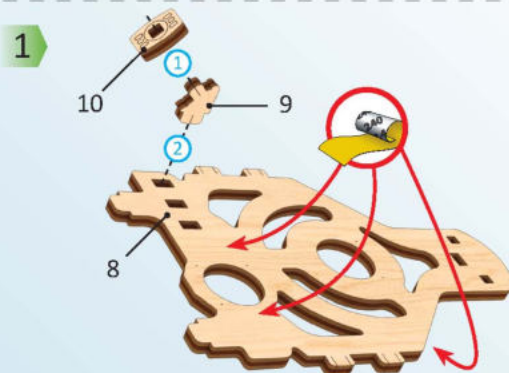
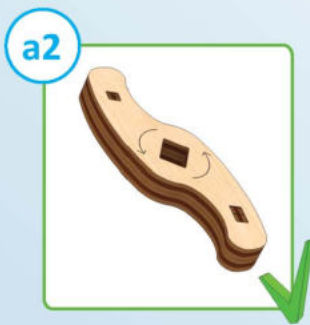
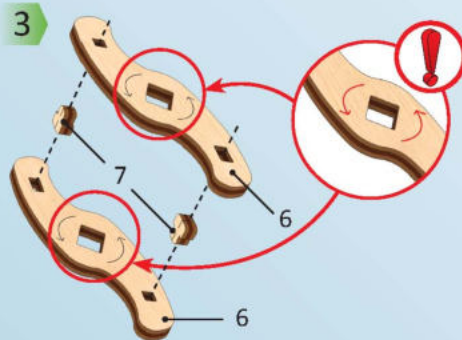
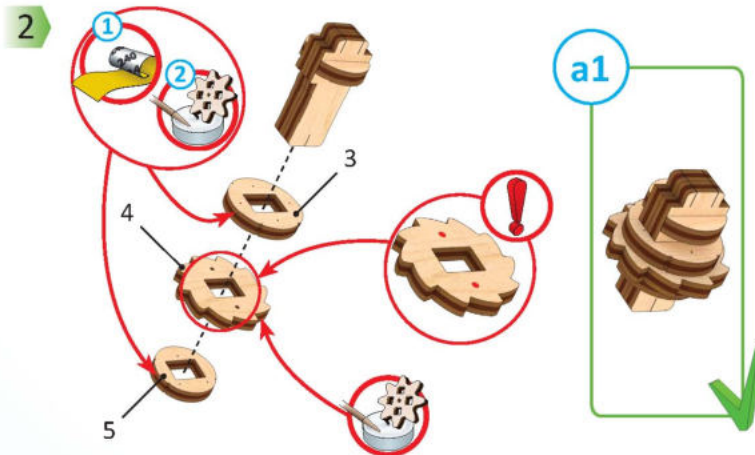
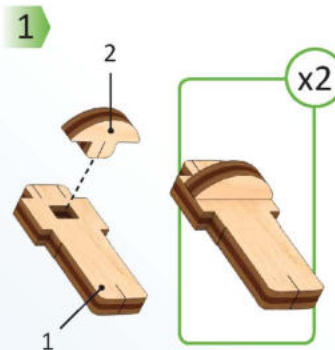

ENG Pay attention. Check position of the part. UKR Зверніть увагу. Переверіть розташування елемента. FRA Faites attention. Vérifiez la disposition de l'élément. DEU Bitte Beachten. Prüfen Sie die Einbaulage des Elementes. SPA Atención. Compruebe la situación del elemento. ITA Prestare attenzione. Controllare la posizione del componente. JPN 方向及び位置に注意して組み立てて下さい。CHI 注意！检查部件方向和位置。RUS Обратите внимание. Проверьте расположение элемента. POL Zwróć uwagę. Sprawdź lokalizację elementu. KOR 방향 또는 위치에 주의해서 조립해 주세요.

ENG Wax the part with a regular candle (rub with a candle). UKR Змастіть деталь звичайною свічкою (потріть об свічку). FRA Lubrifiez la pièce avec une bougie ordinaire (frottez contre la bougie). DEU Reiben Sie das Teil mit einer einfachen Kerze etwas ein. SPA Engrase la pieza con una vela común (frote con una vela). ITA Incerare il componente (sfregare con la cera). JPN された部分に潤滑剤として口ウソクを塗ってください。CHI 用普通蠟燭塗抹潤滑部件。RUS Смажьте деталь обычной свечкой (потрите о свечку). POL Przesmaruj zwykłą świecą. KOR 표시된 부분에 윤활을 위해 촛를 칠해 주세요.

ENG Sand to remove burrs. UKR Видаліть задирки. FRA Éliminez les bavures. DEU Grate entfernen. SPA Quite las rebabas. ITA Togliere le bave. JPNバリ取りのサンドペーパー。CHI 磨掉毛刺。RUS Удалите заусенцы. POL Usuń zadziory. KOR 거친 부분을 닦아주세요.

3

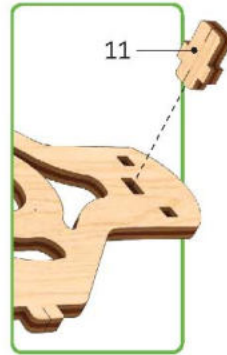

4

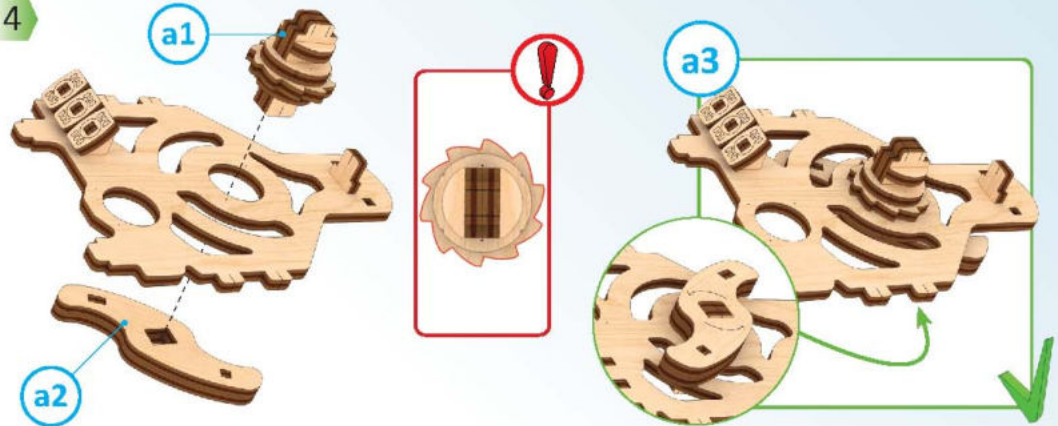

3

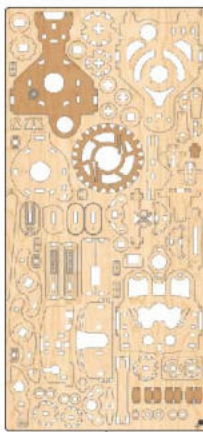
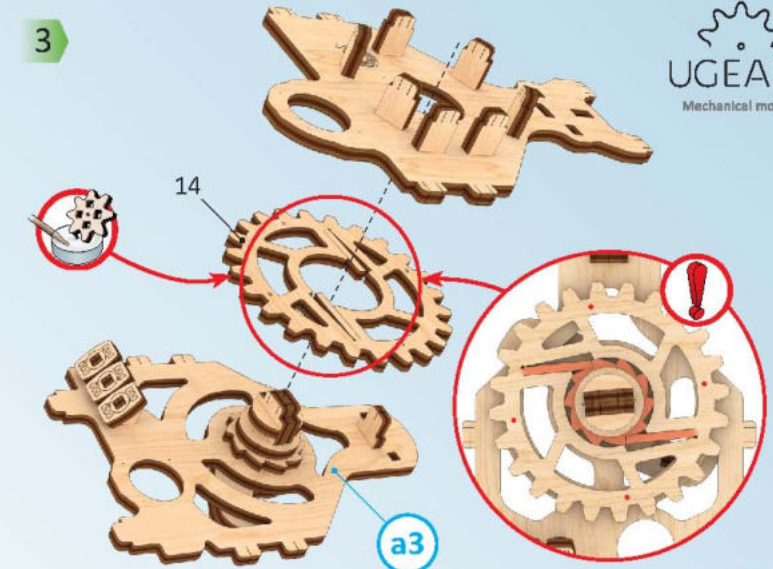

1

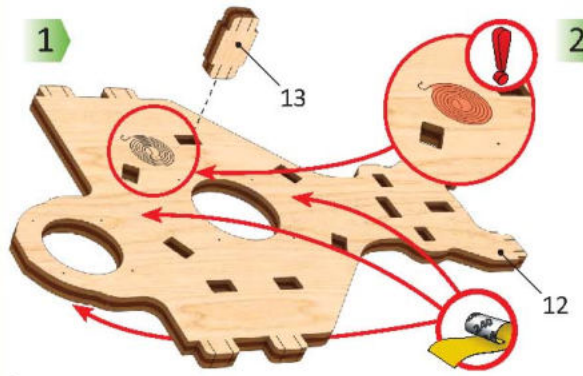

2

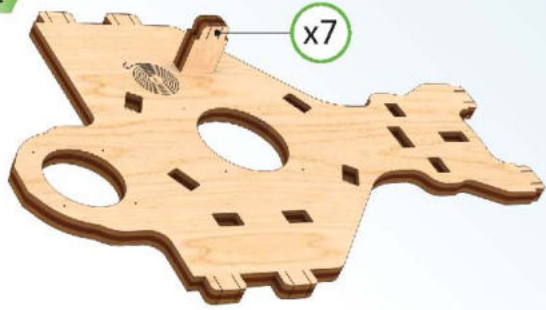

ENG Check the mechanism for smoothness and accuracy of movement. Operate the mechanism so the parts would seat-in. **UKR** Перевірте механізм на плавність і точність ходу. Розробіть механізм. **FRA** Vérifiez si le mécanisme fonctionne en douceur et avec précision. Faites fonctionner le mécanisme jusqu'à son fonctionnement normal. **DEU** Prüfen Sie den Mechanismus bezüglich der Laufruhe und der Genauigkeit des Ganges. Betätigen Sie den Mechanismus mehrmals. **SPA** Verifique la suavidad y precisión del mecanismo. Desarrolle el mecanismo. **ITA** Controllare la scorrevolezza e la precisione del movimento. Far funzionare il meccanismo. **JPN** 駆動部分が滑らかに動くかを確認しながら作業をすめます。 **CHI** 检查机构的运行平滑度和精确度。调整机构。 **RUS** Проверьте механизм на плавность и точность хода. Разработайте механизм. **POL** Sprawdź płynność i dokładność ruchu mechanizmu. Dopracuj mechanizm. **KOR** 구동 부분의 원활한 작동과 정확한 움직임을 확인하세요.

1

5

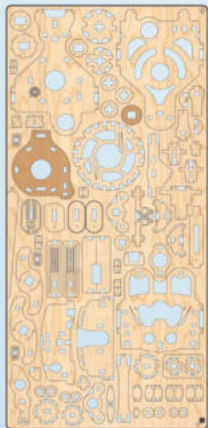

4

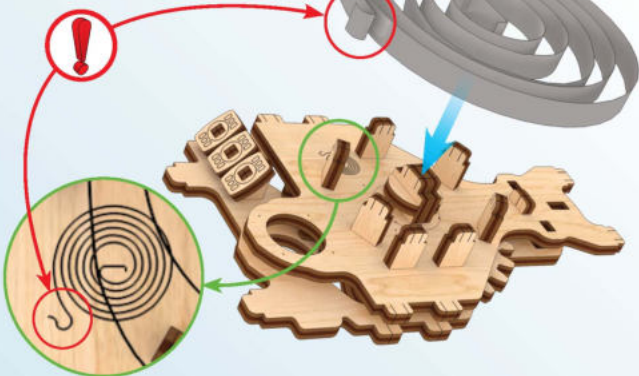

5

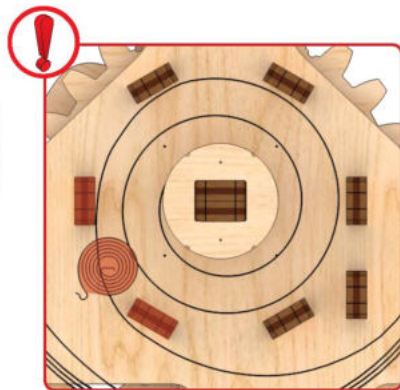
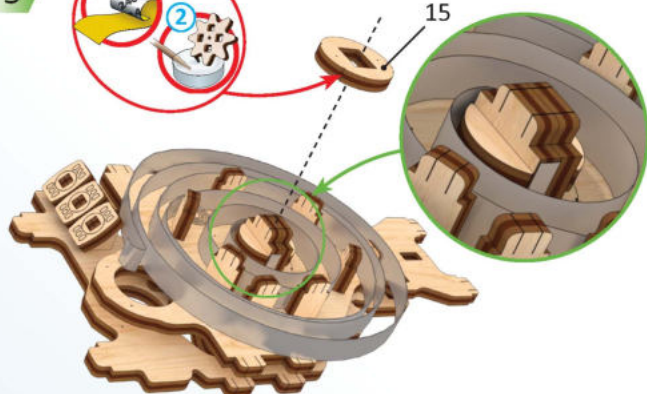

6

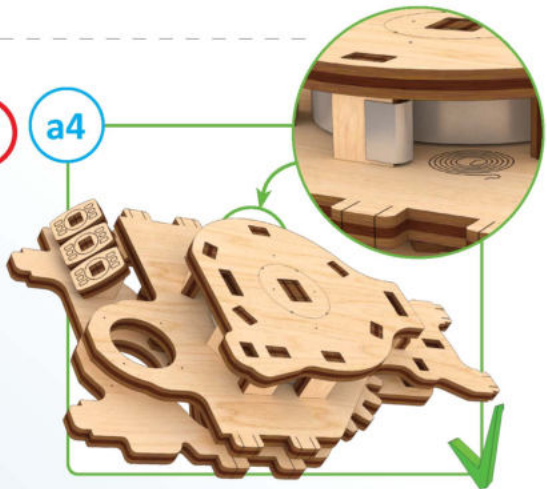
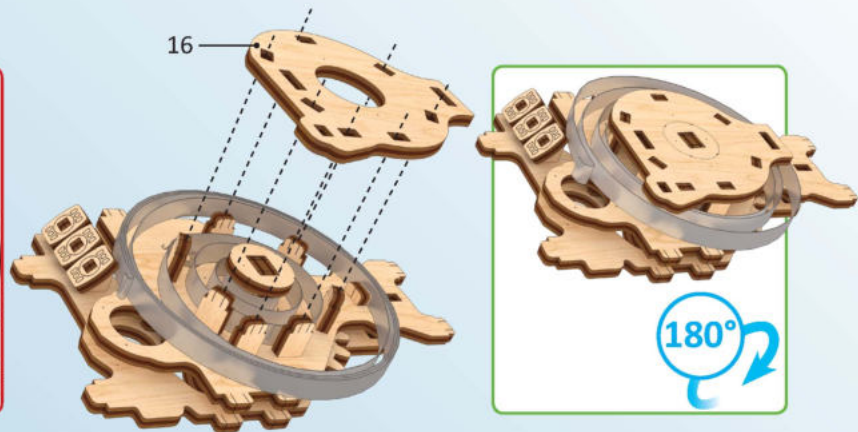
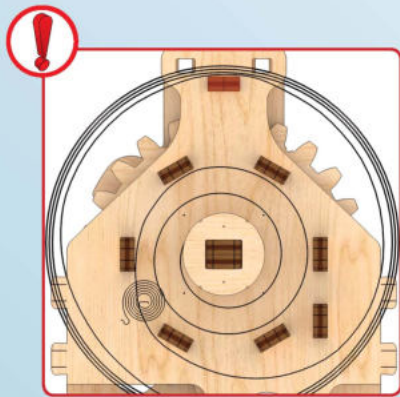

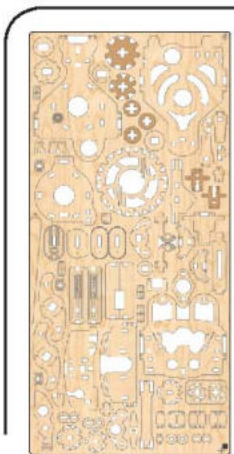

①

1

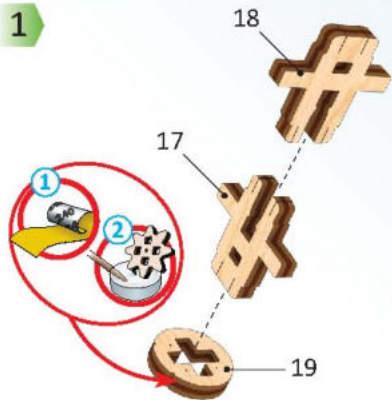

2



3



4

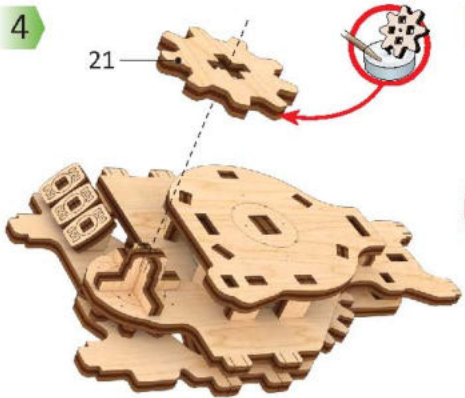

5

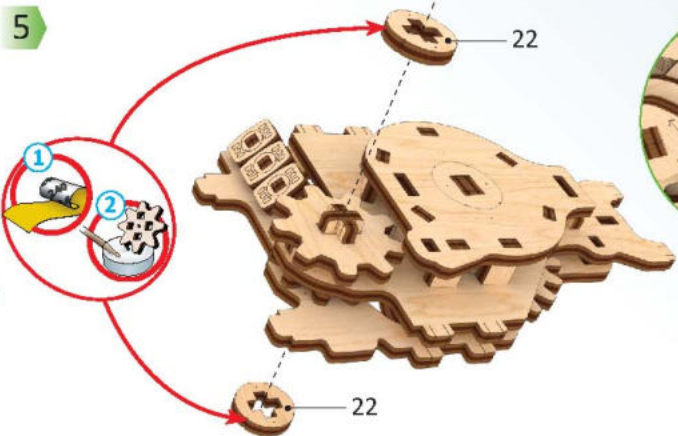

a5



7

Mechanical models

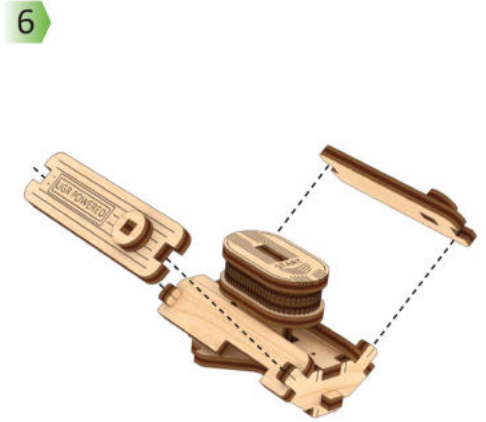
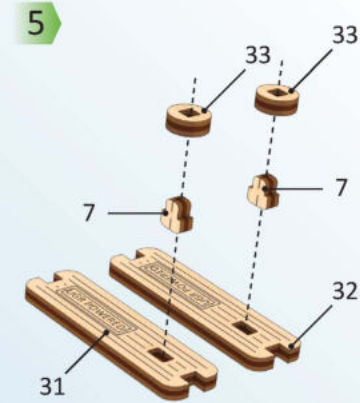
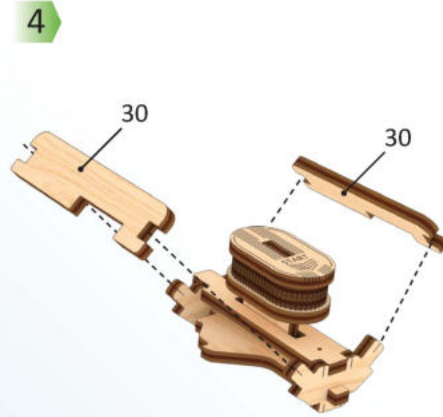
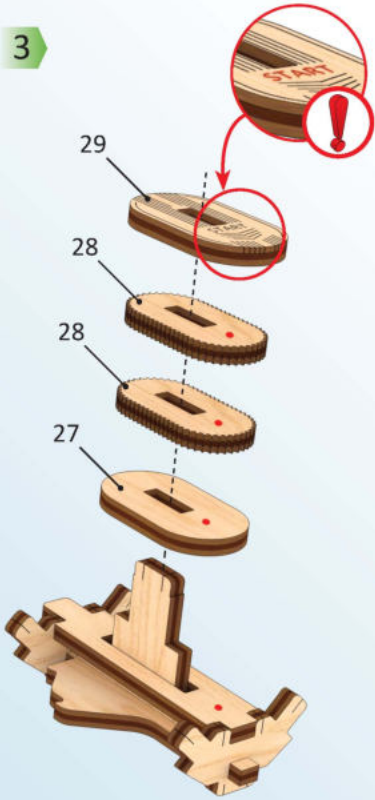
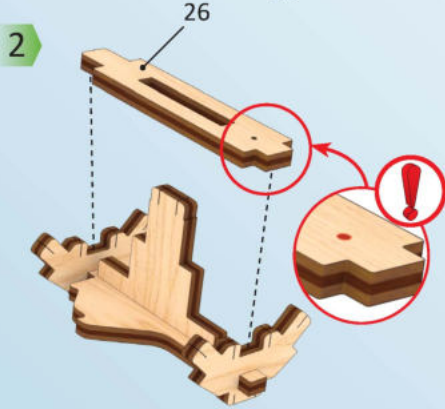
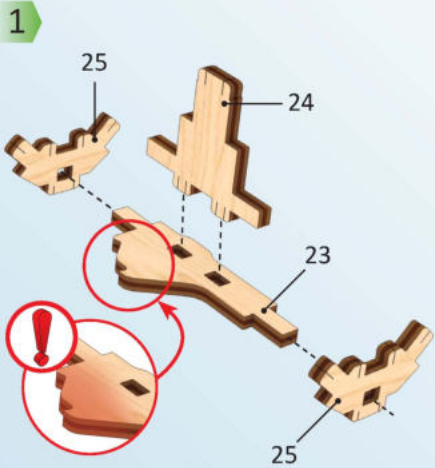
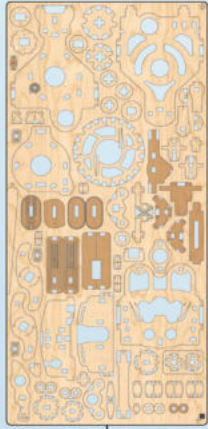

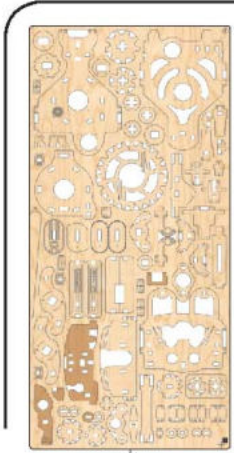

1

1

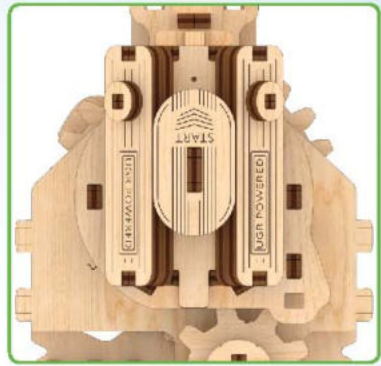
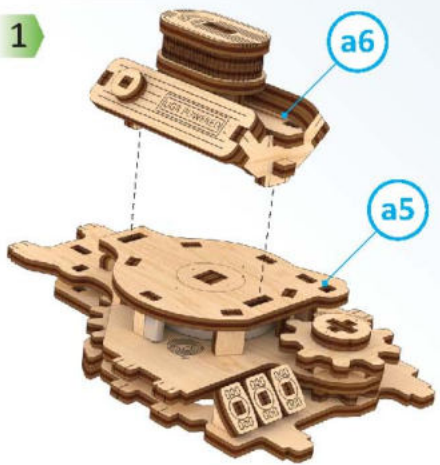

2

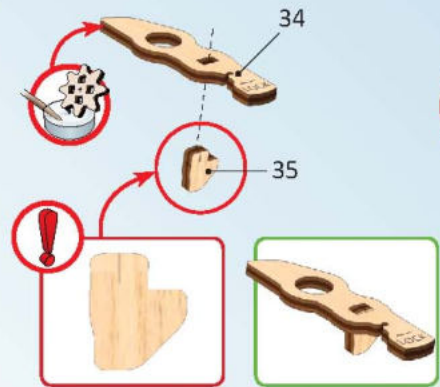

3



4

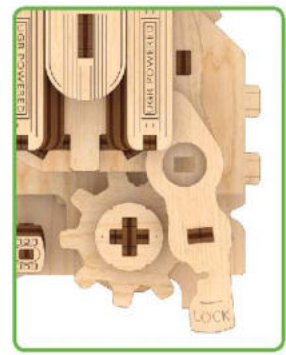

5

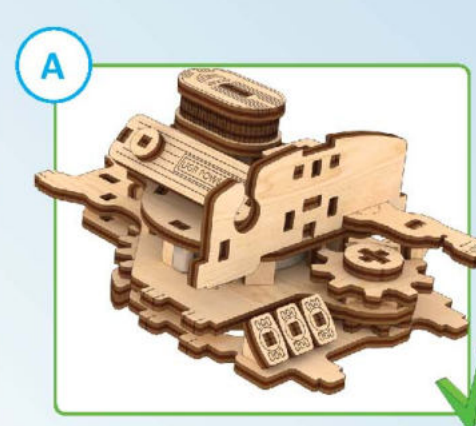
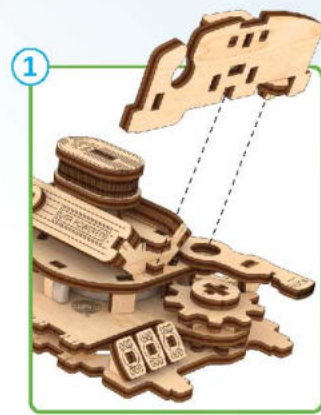

9

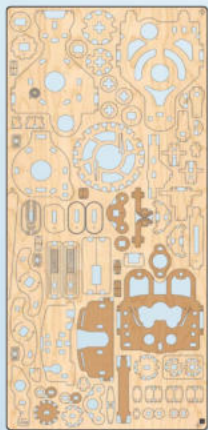

1

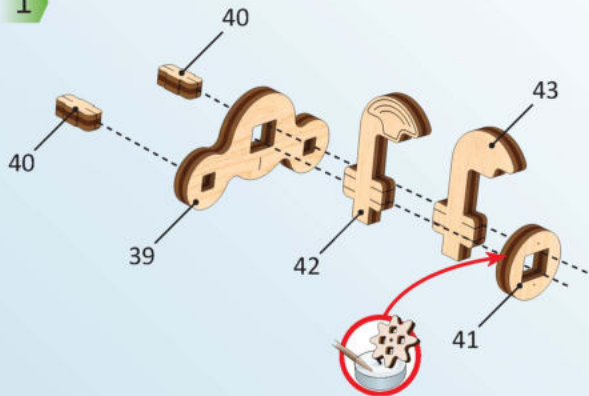

1

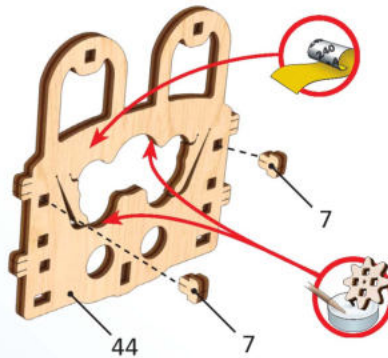

2

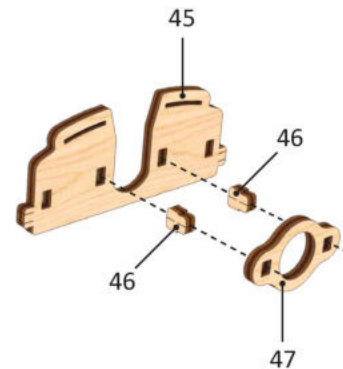

3

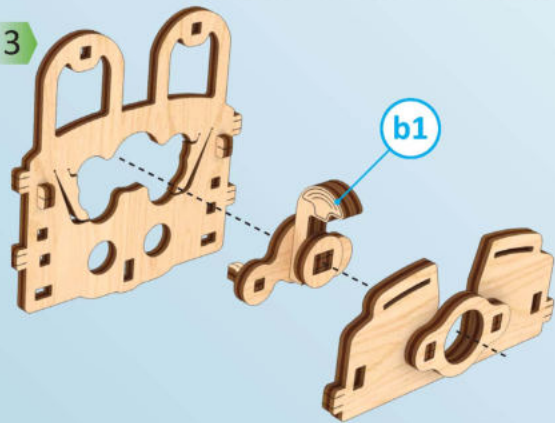

b1

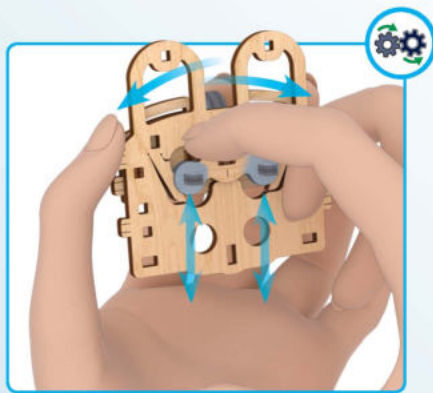

4

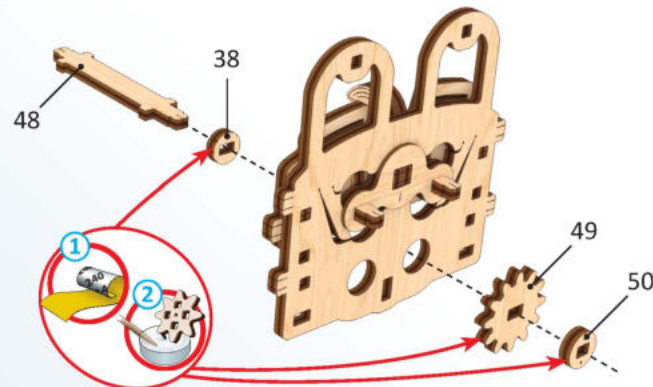

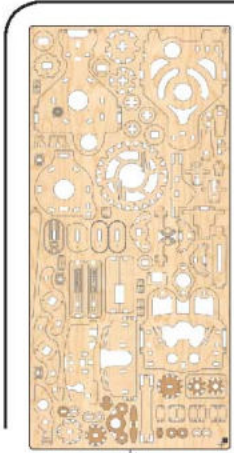

①

5

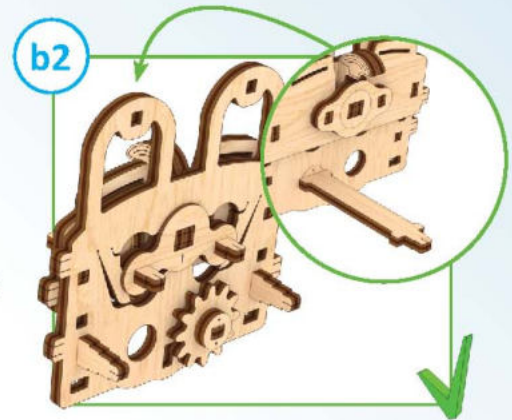
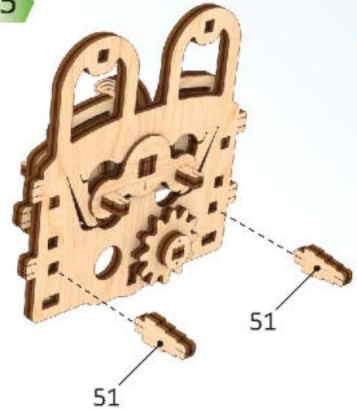

1

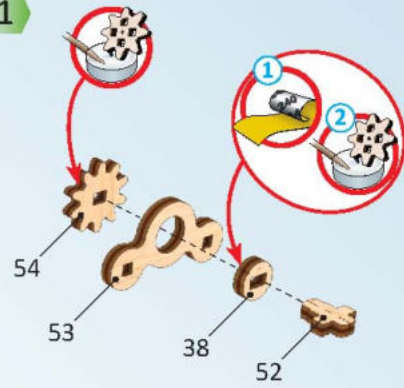

2

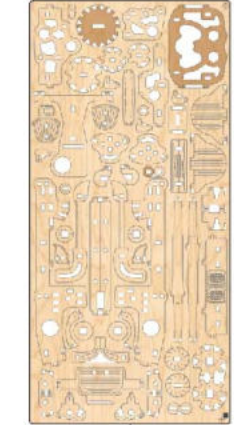
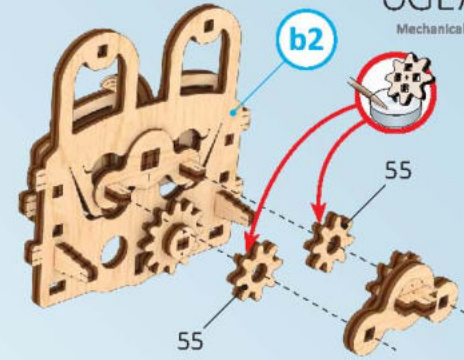

②

3

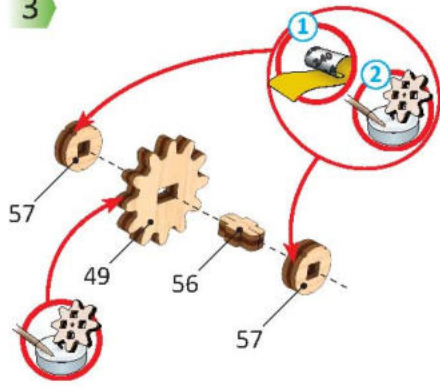

4

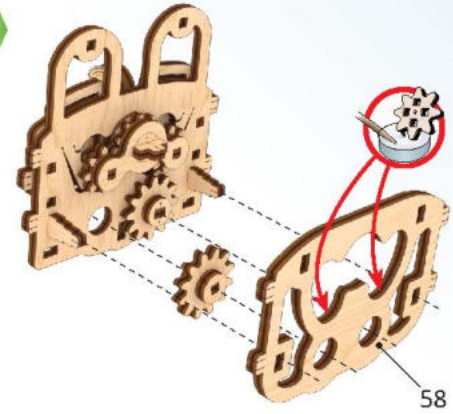

5

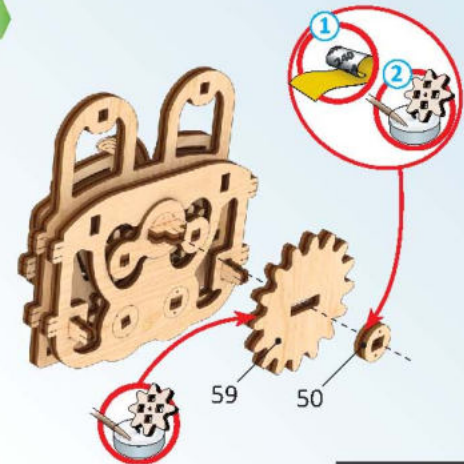

b3



1

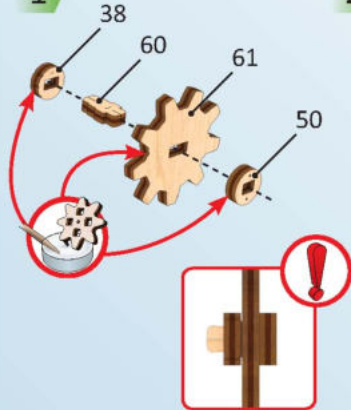

2

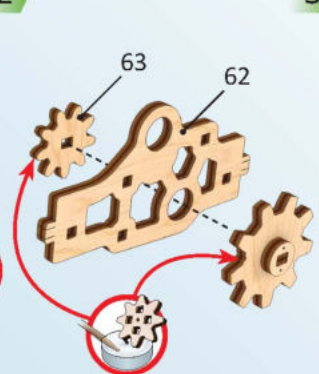

3

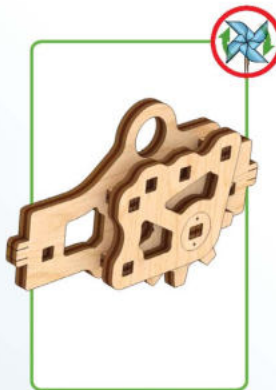
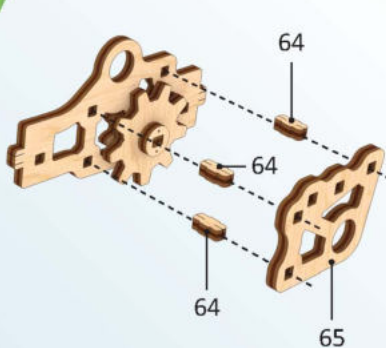

4

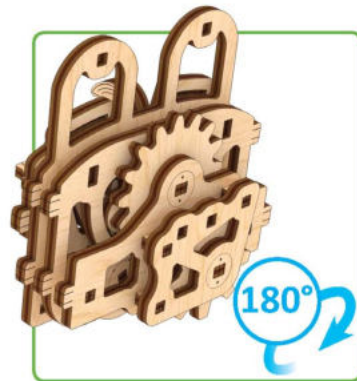
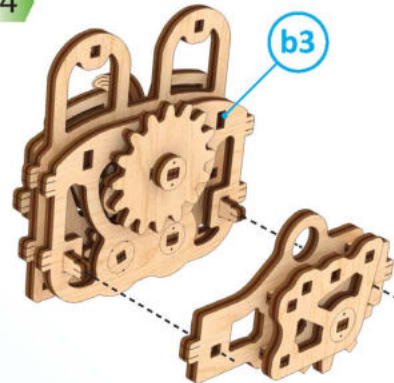

5

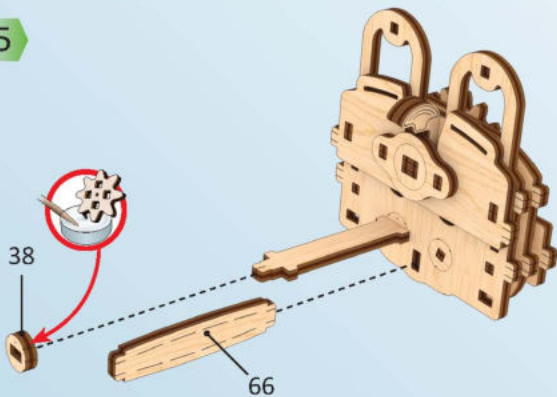

6

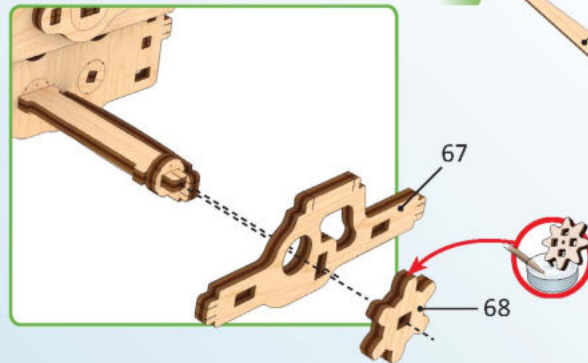

7

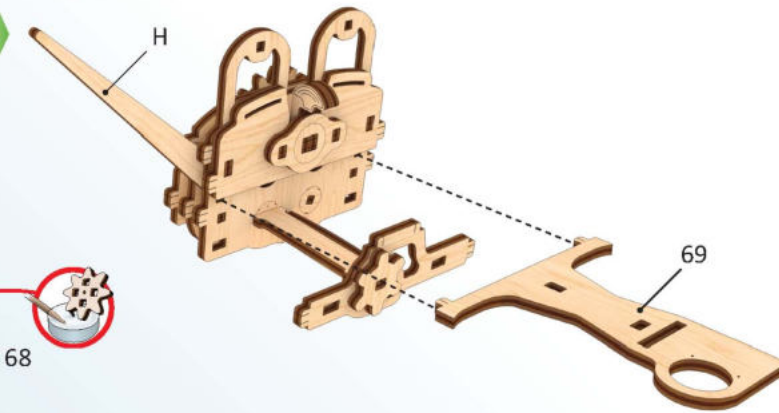

ENG The part should be easily rotated (moved). UKR Деталь повинна легко крутитися (рухатися). FRA La pièce doit tourner (se déplacer) aisément. DEU Der Teil soll leicht gedreht (bewegt) werden. SPA La pieza debe ser fácil de girar (mover). ITA Il componente deve girare (muoversi) facilmente. JPN 部品はしっかりと動かなければなりません。CHI 此部件必须容易的旋转 (移动) POL Element powinien łatwo się kręcić (poruszać się). RUS Деталь должна легко крутиться (двигаться). KOR 활하게 움직일 수 있어야합니다.

8

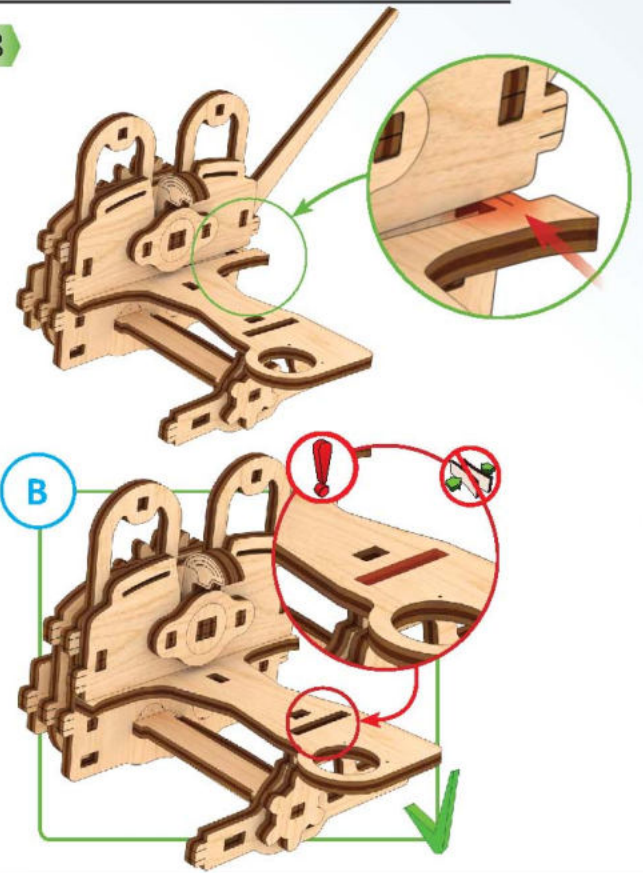

1

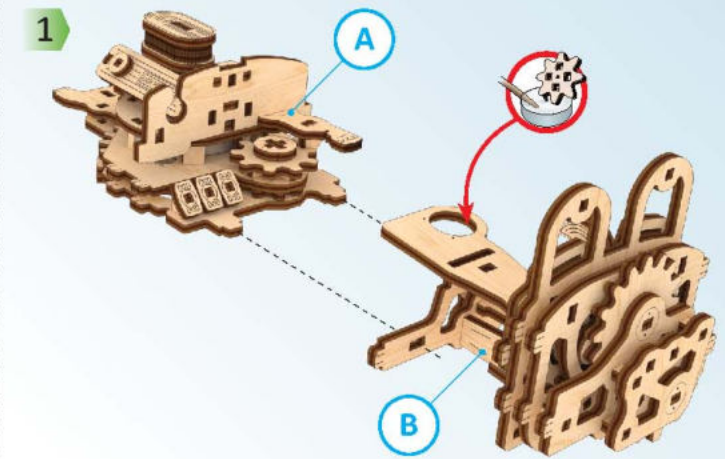

2

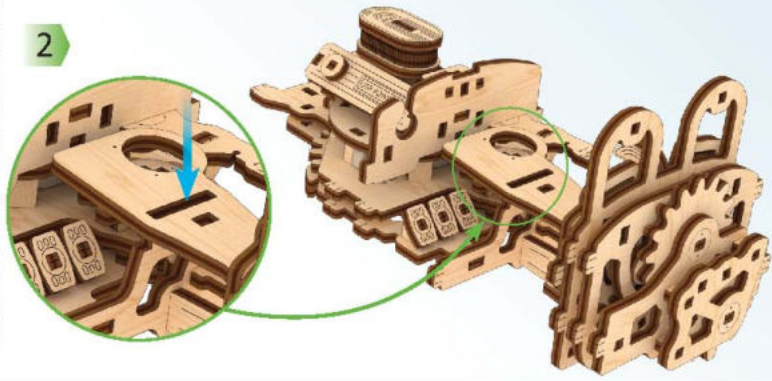

C

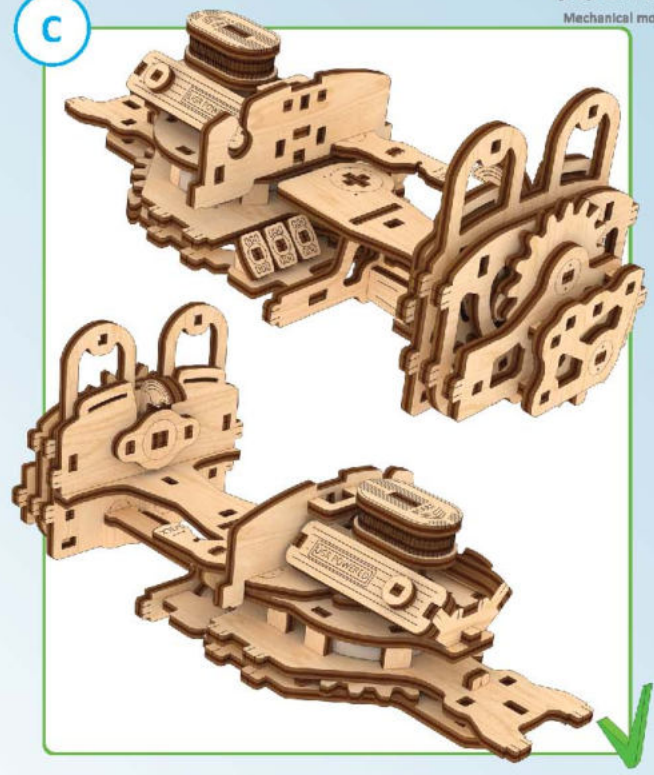

ENG Do not fully press the outer parts (structural frame) together until checking for fit and alignment of internal parts. UKR Деліть час не притискайте сильно деталі (рамки конструкції). FRA Ne pas forcer sur les pièces (cadre de la construction). DEU Drücken Sie die Teile (die Rahmen der Konstruktion) momentan nicht stark. SPA No presione temporalmente con fuerza las piezas (marco de la estructura). ITA Non stringere provvisoriamente i componenti con forza (base della costruzione). JAP 内部部品がしっかりと組み立てられる前に外部部品は強く押しながら固定してはいけません。CHI 在檢查內部零件的配合和对准之前，请暂时不要将外部零件（结构框架）完全压在一起。RUS Временно сильно не прижимайте детали (рамки конструкции). POL Tymczasowo nie dociskaj elementów (ramy konstrukcji). KOR 아직은 외부의 틀을 완전히 눌러서 고정하면 안됩니다. 다른 부품을 먼저 끼우세요.

Mechanical models

1

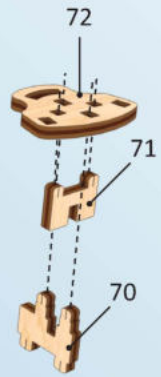

2



3

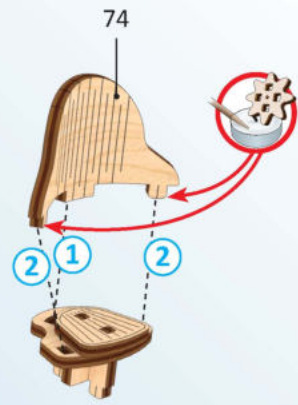

x2



4



5

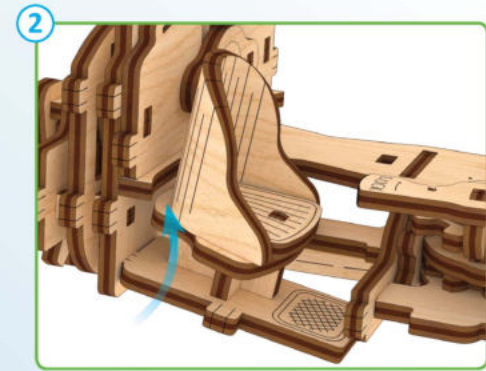
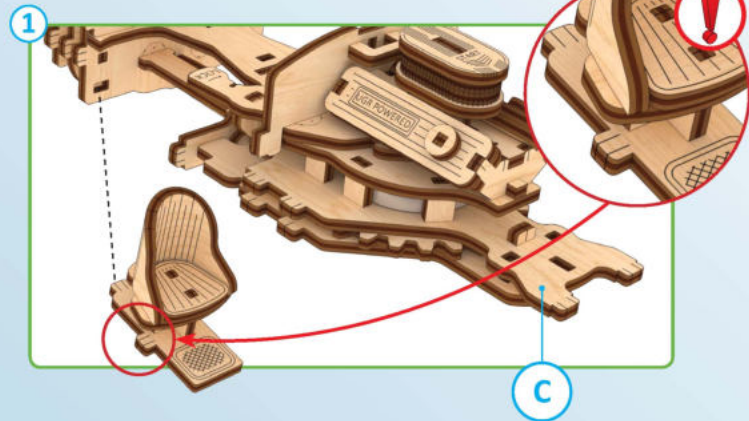
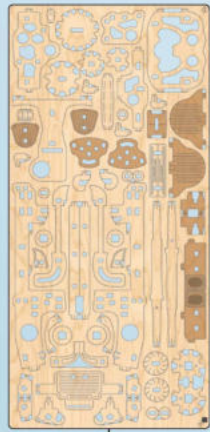

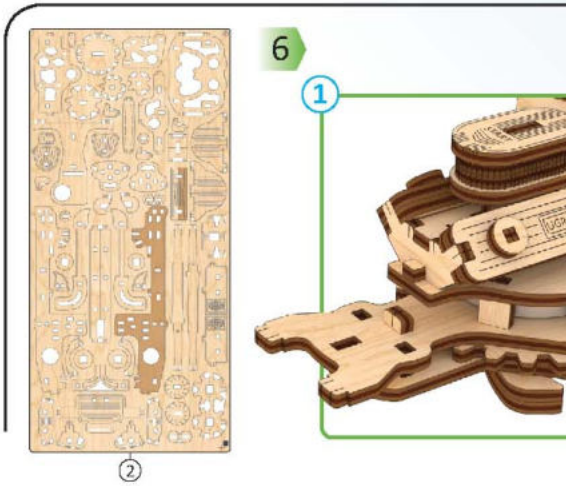

6

1

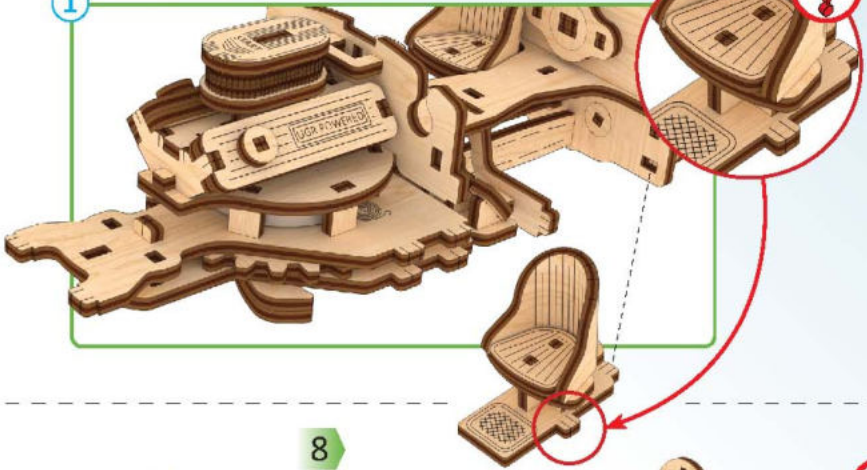

2



7

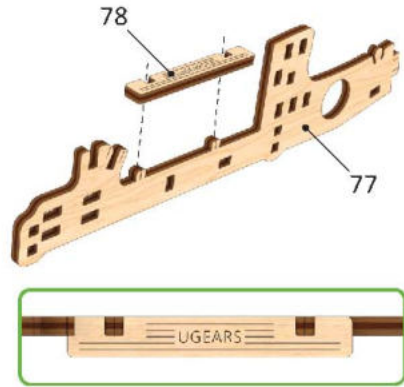

8

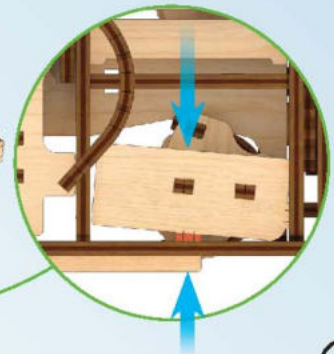
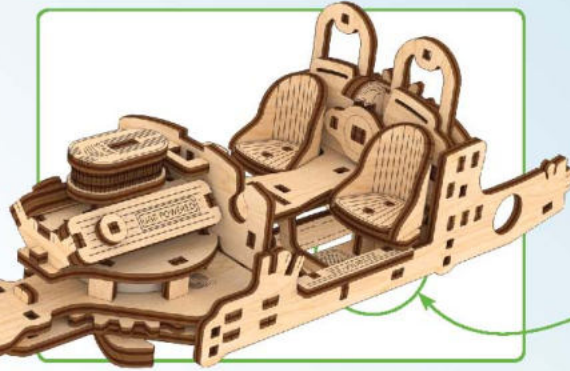
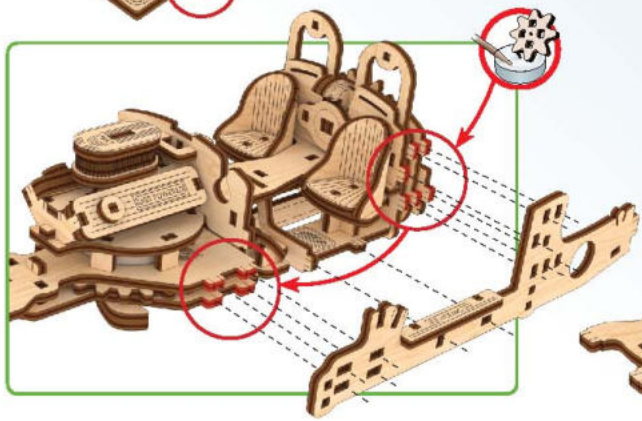

Mechanical models



9

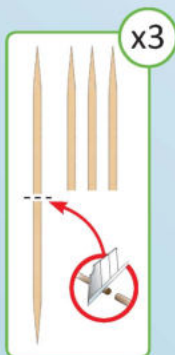
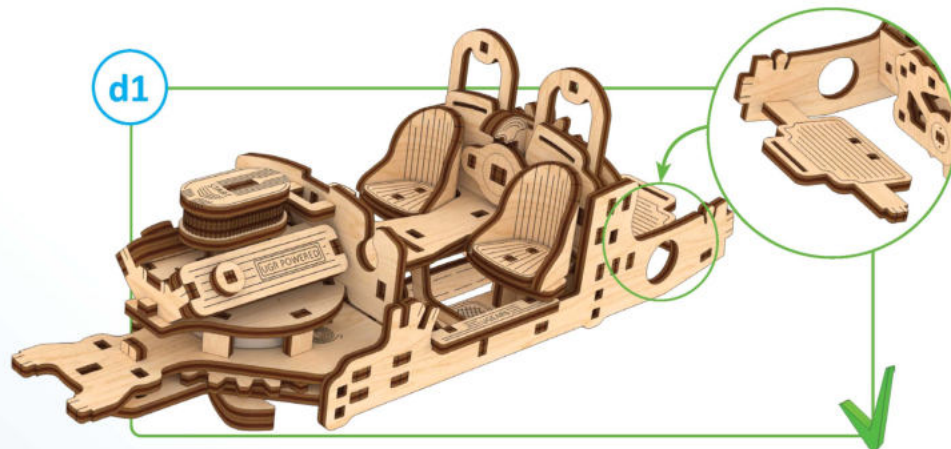
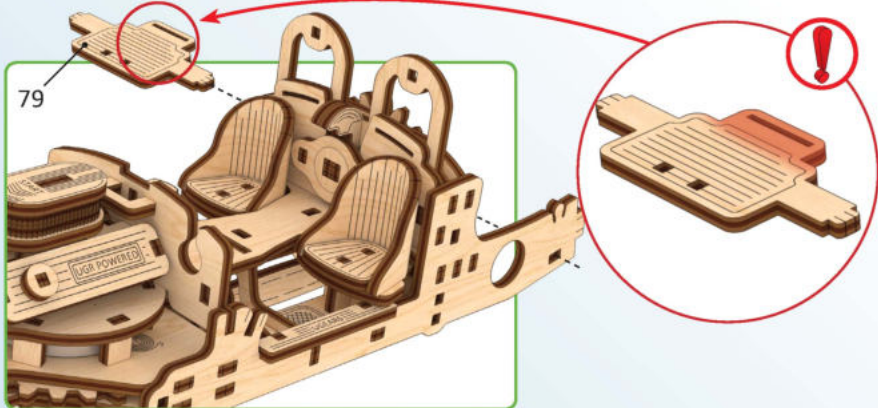

1

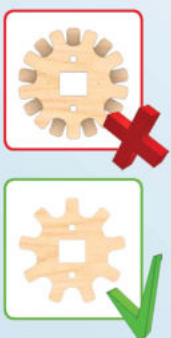
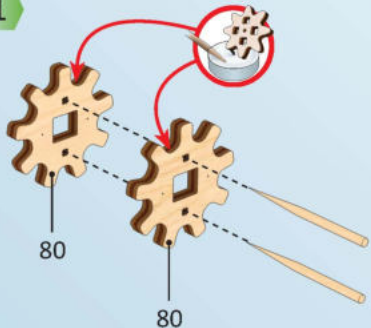

2

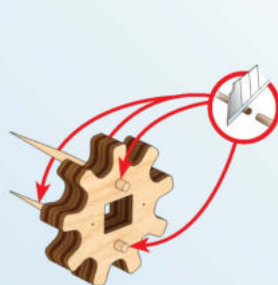

3

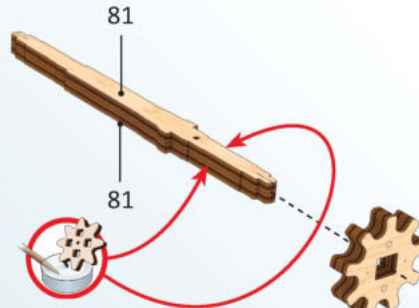

4

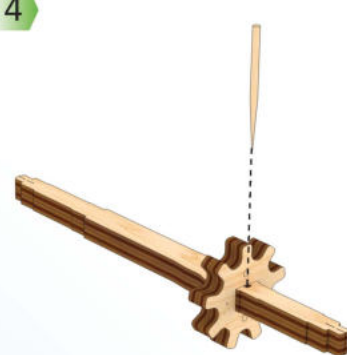

5

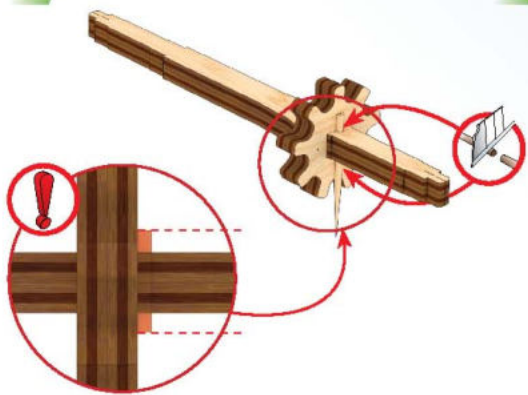

6

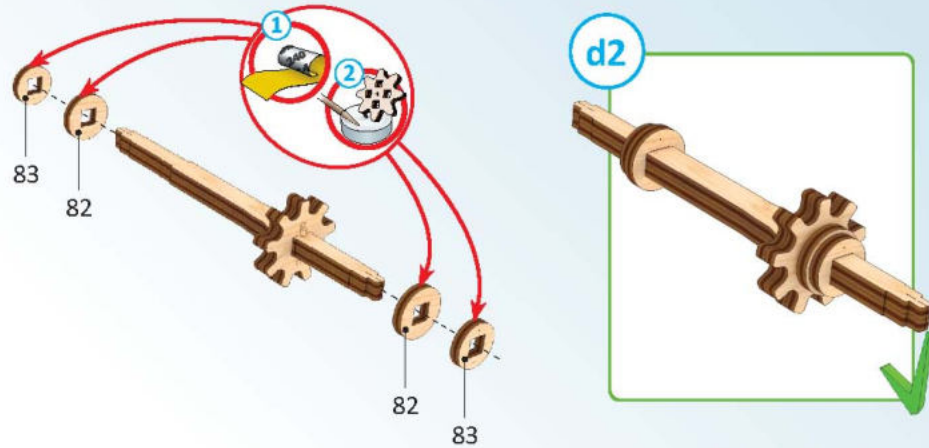

1

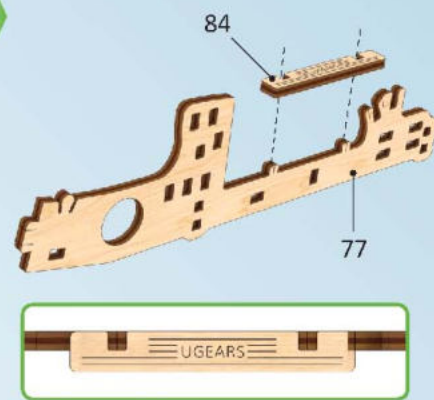

2

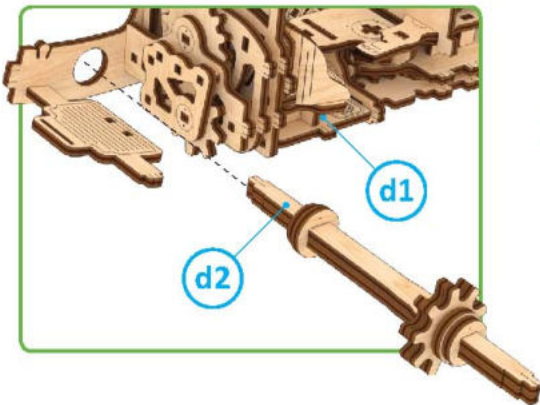

3

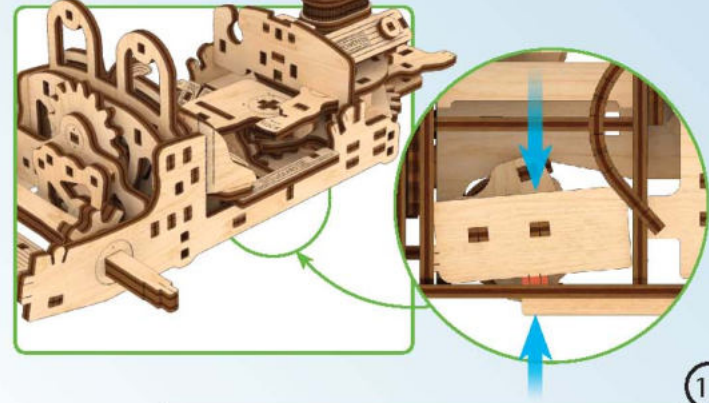
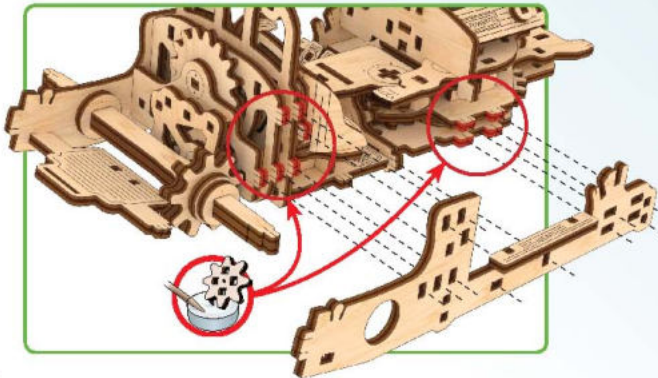

4

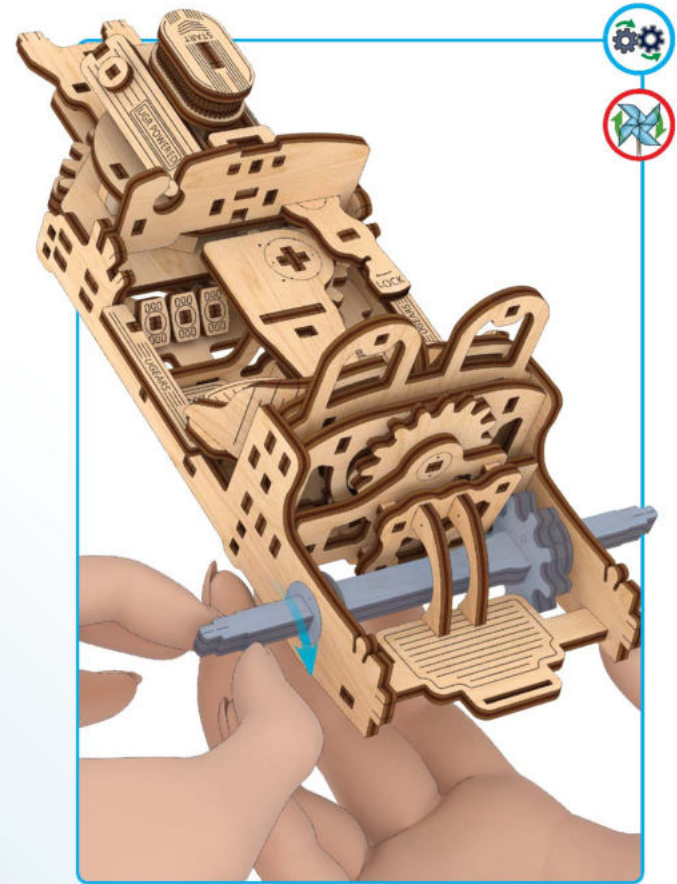
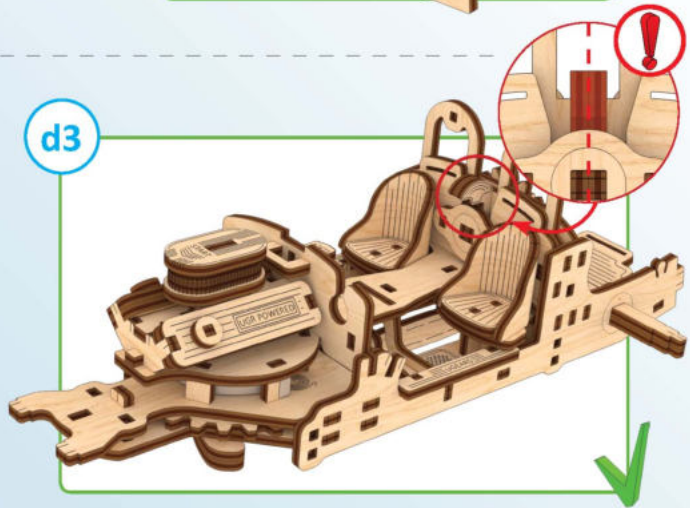
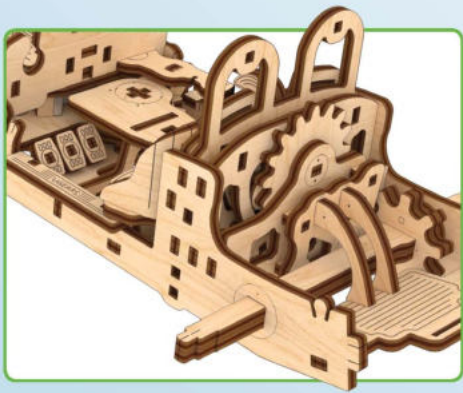
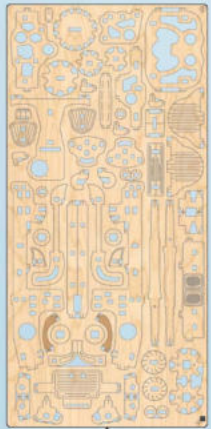
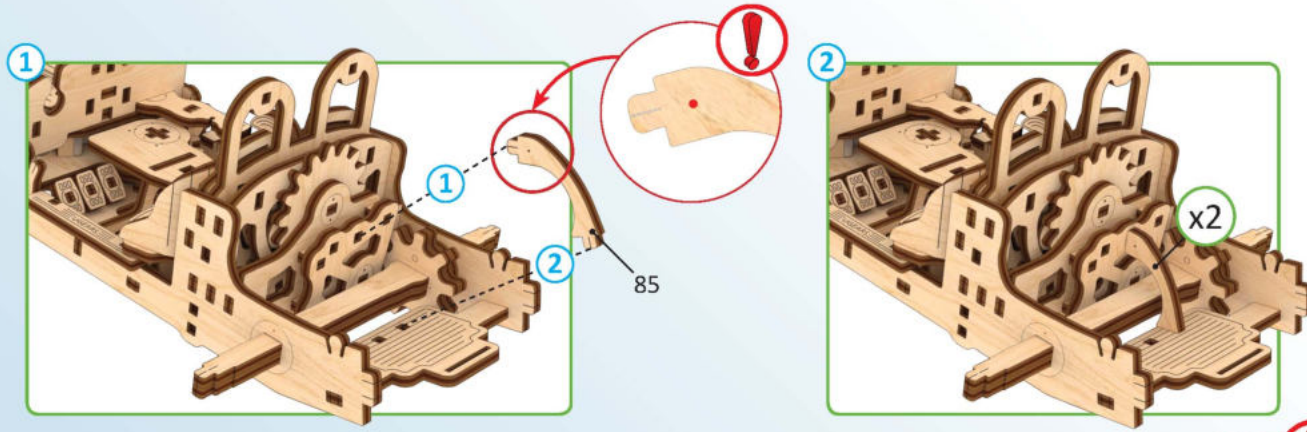

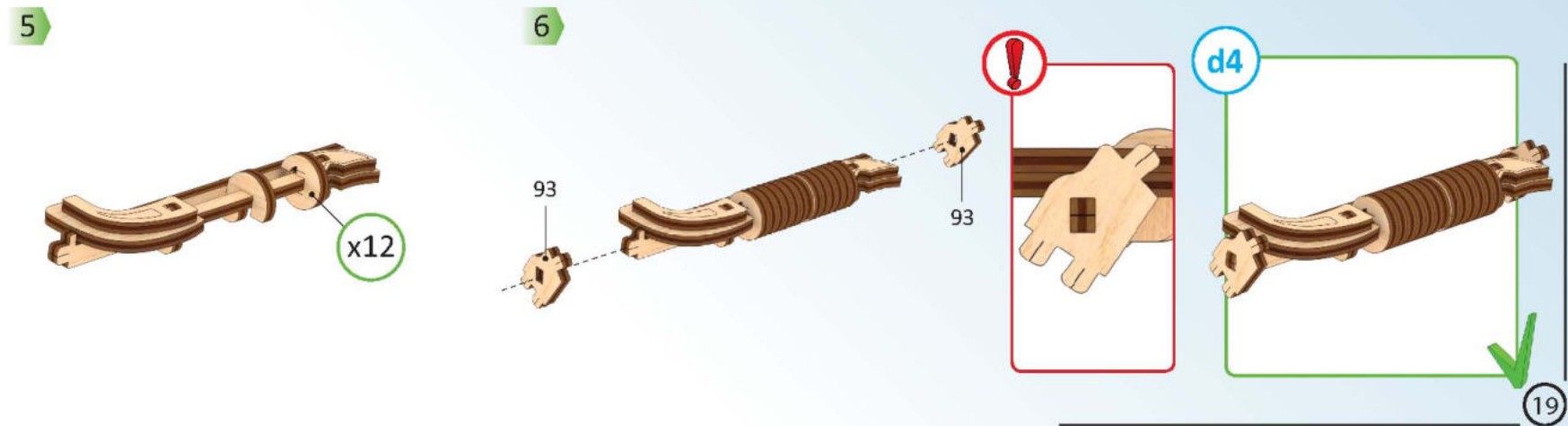
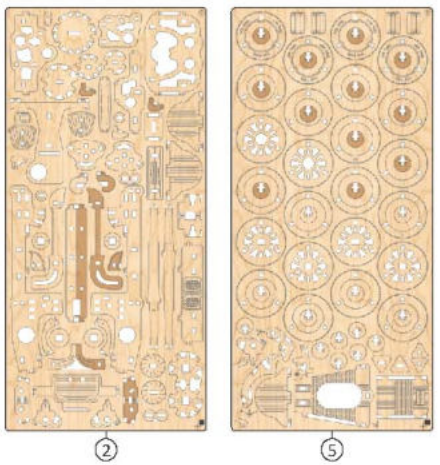
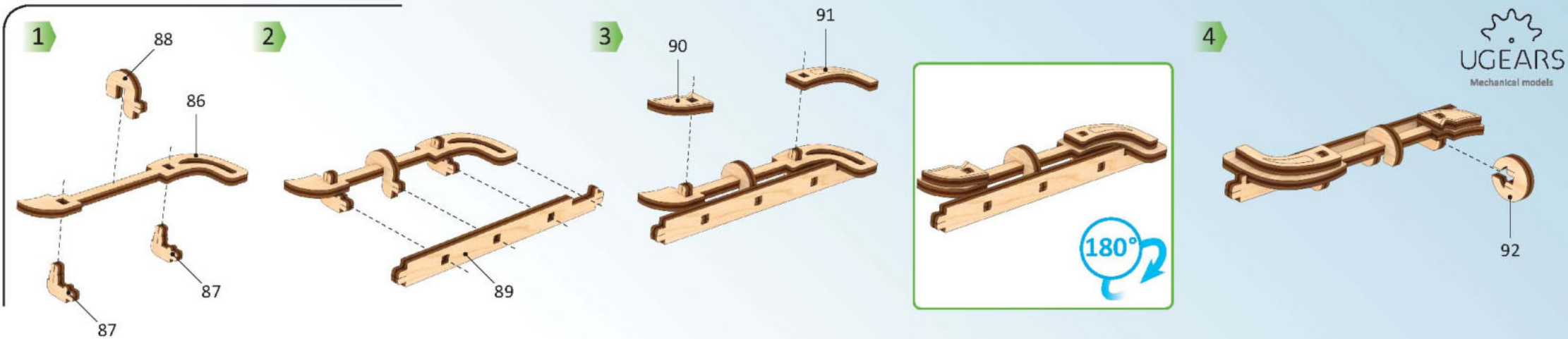

1

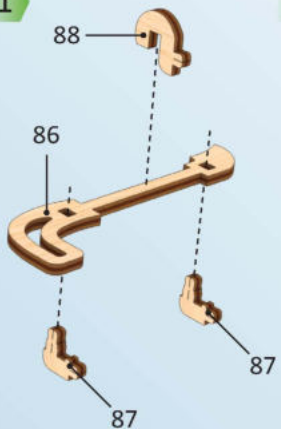

2

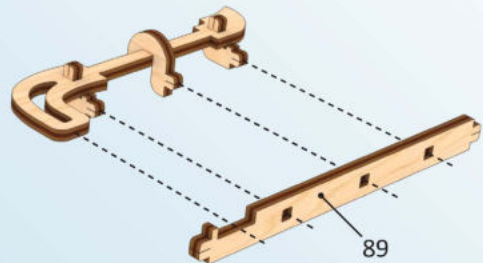

3

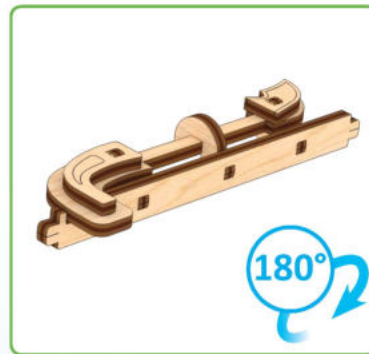
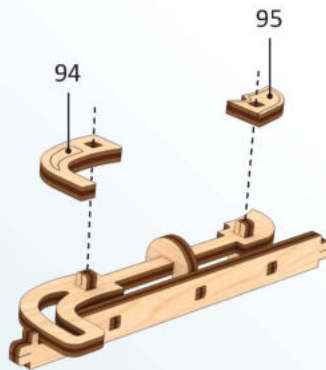

4

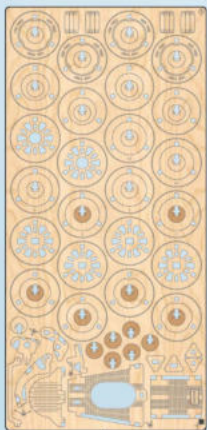
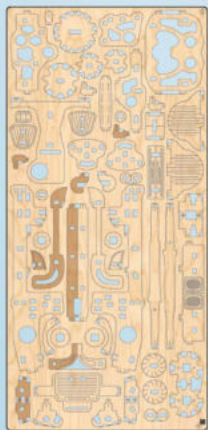
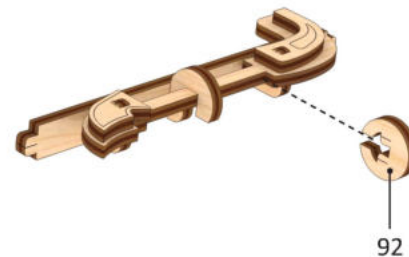

5

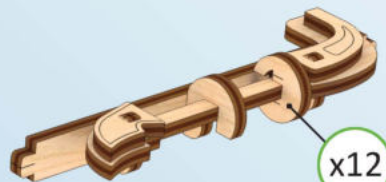

6

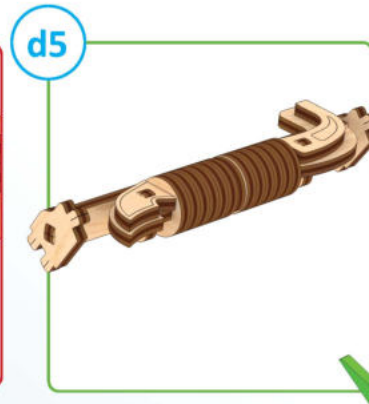

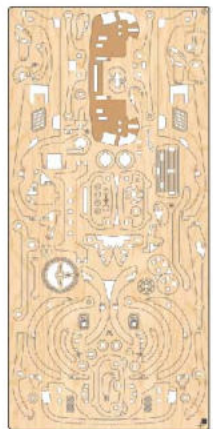

1

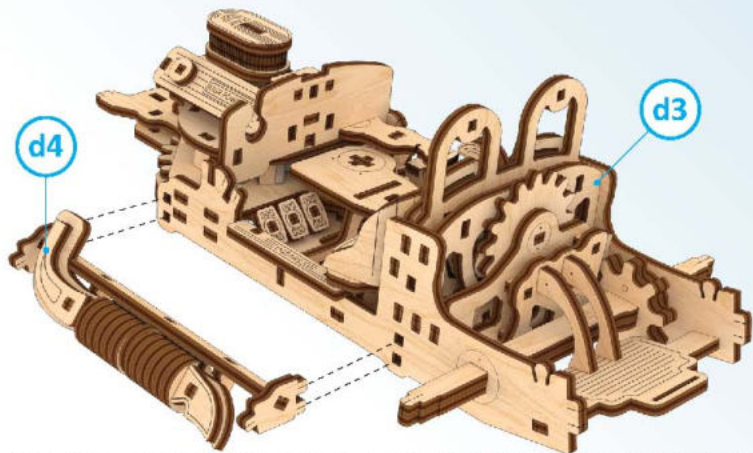

2

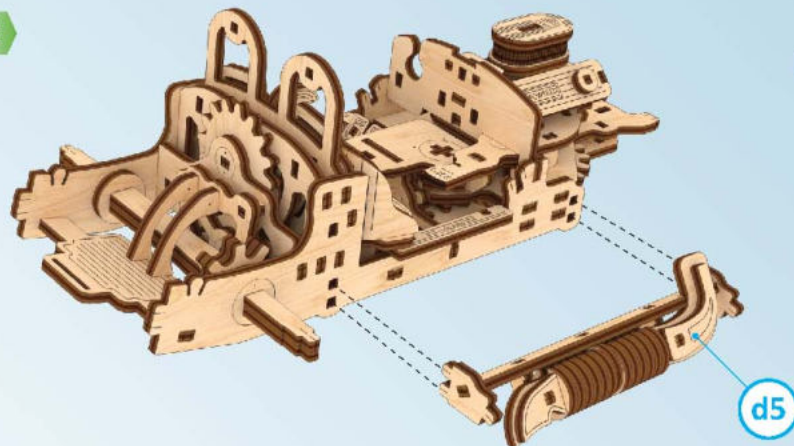

3

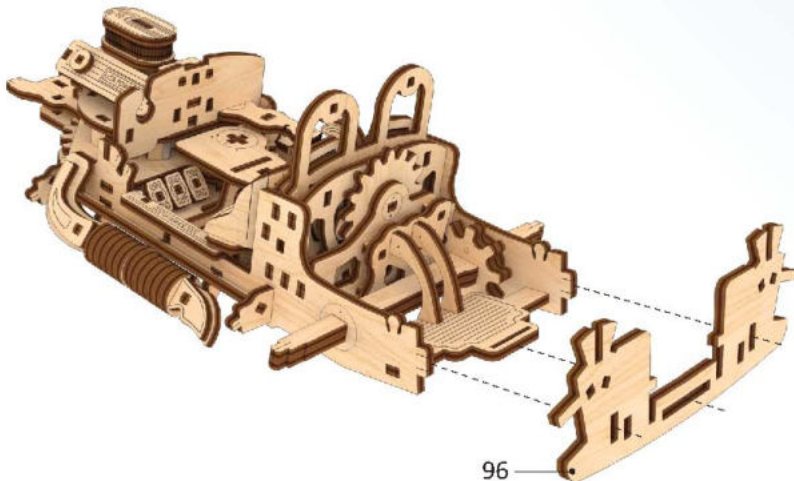

D

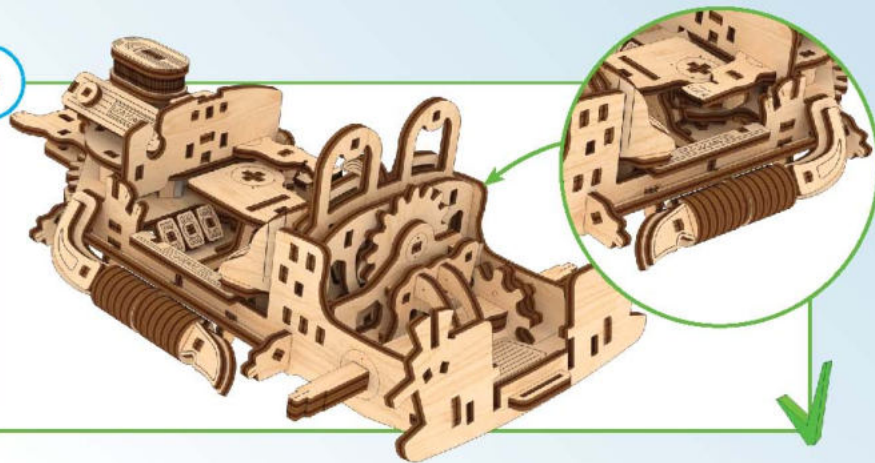

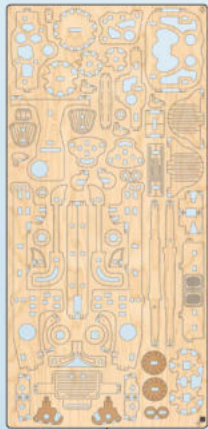

②

1

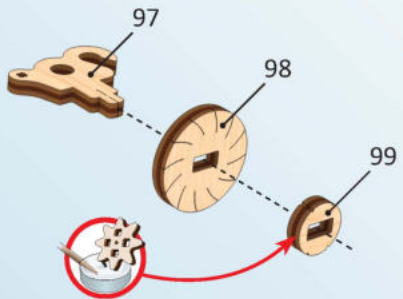

2

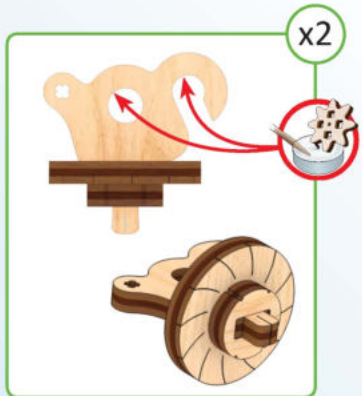

3

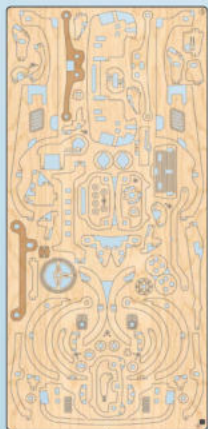
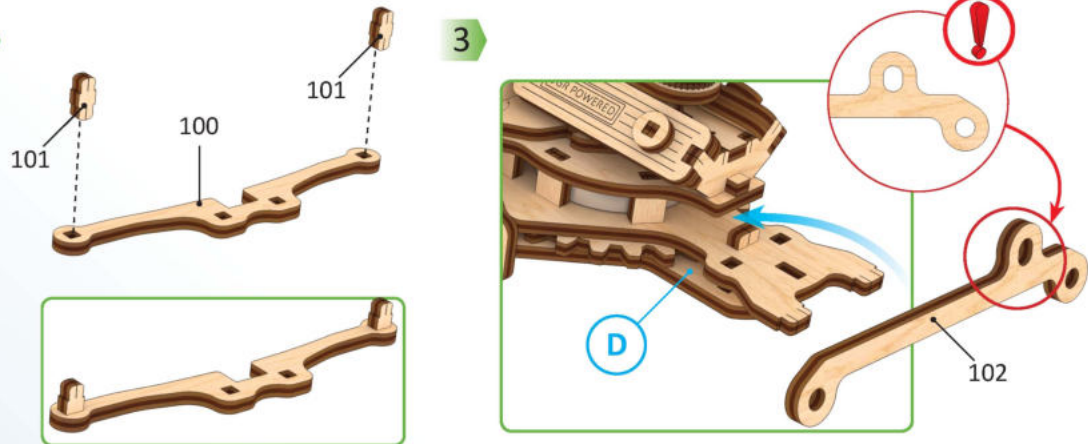

③

4

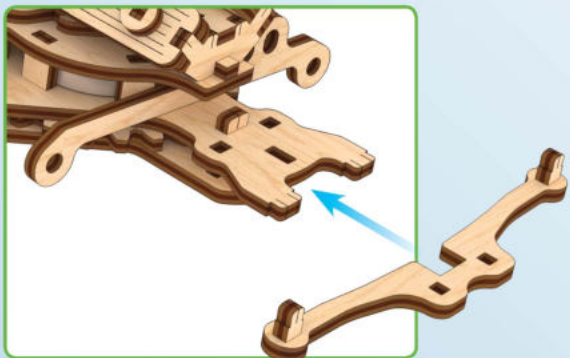

5

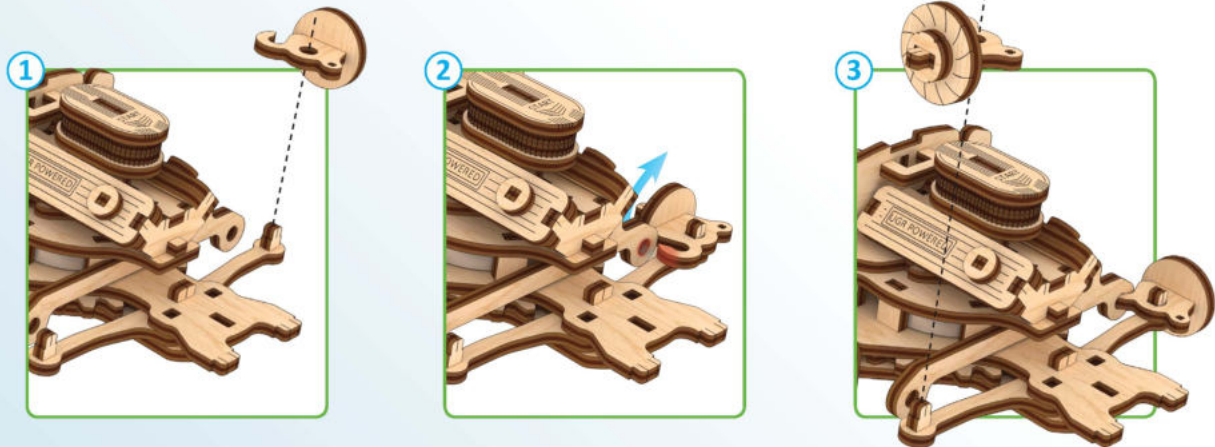

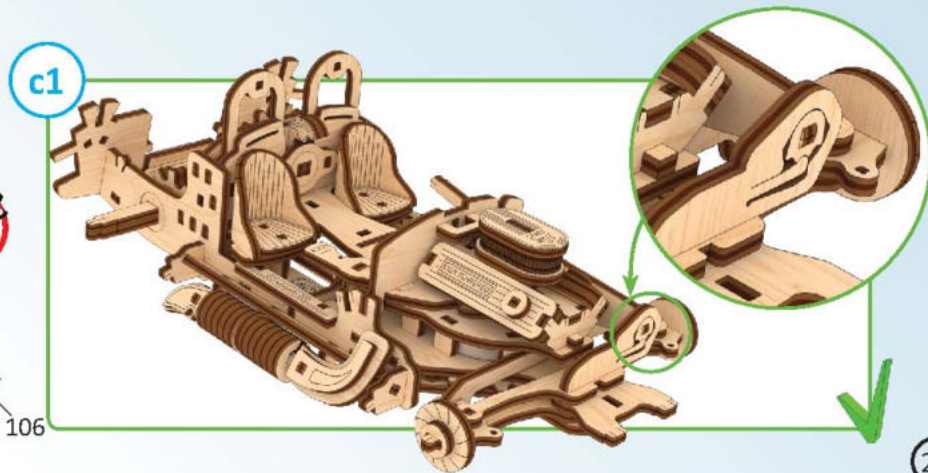
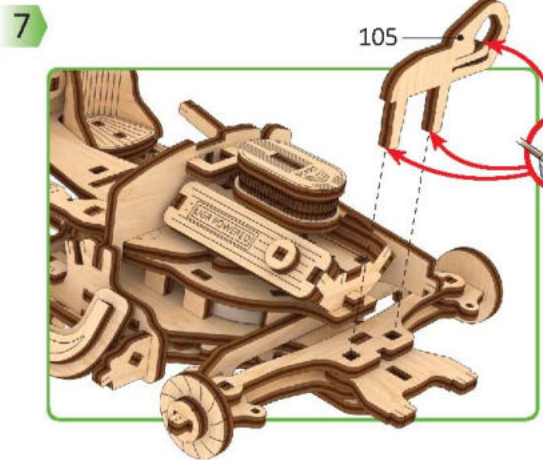
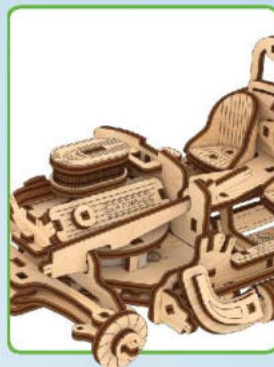
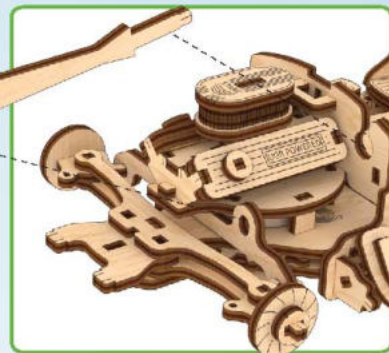
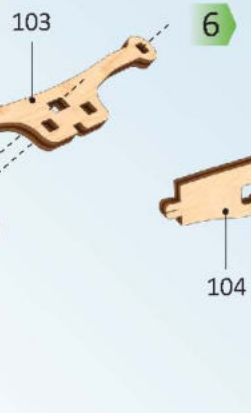
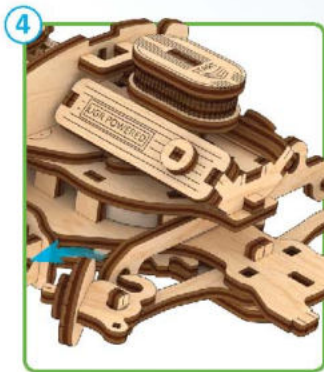
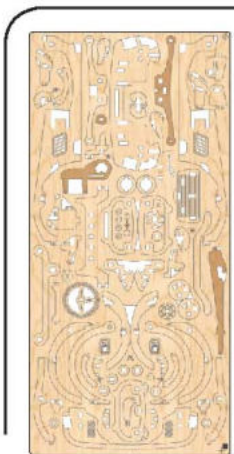

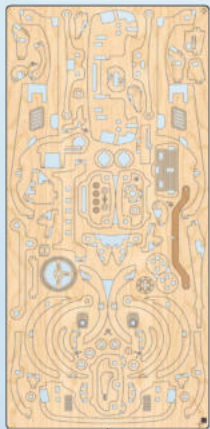

③

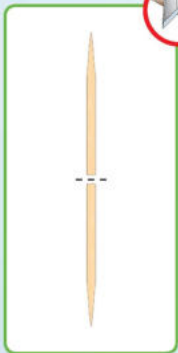

1

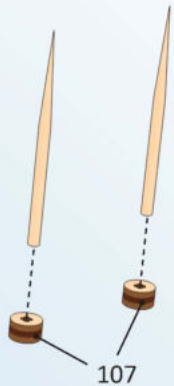

107

2

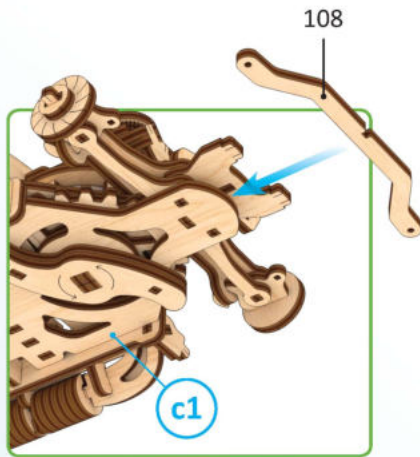

108

c1

3



4

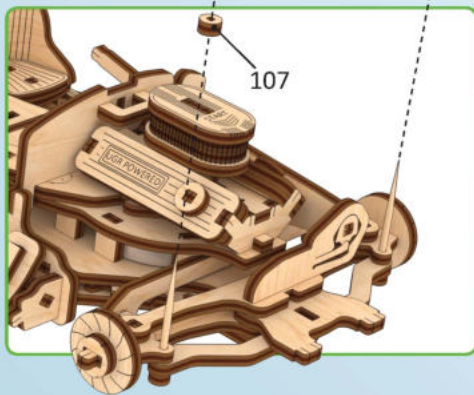

107

107

5

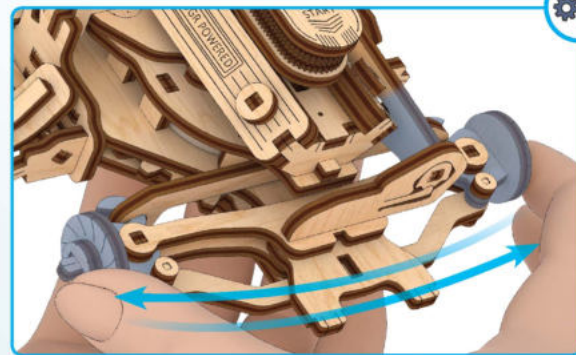
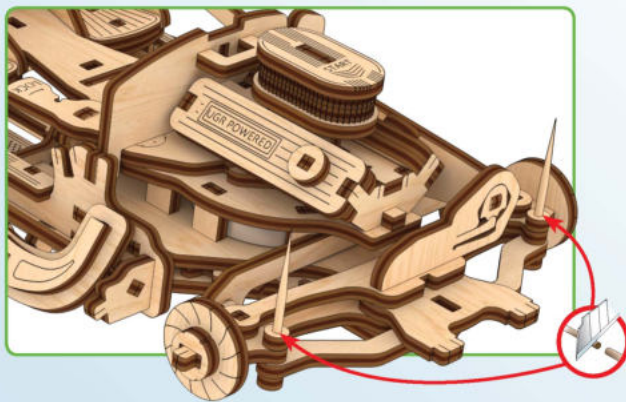

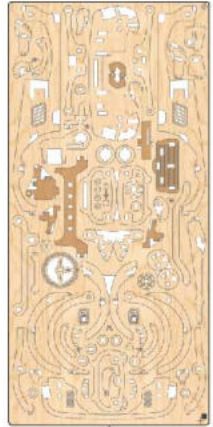

③

6

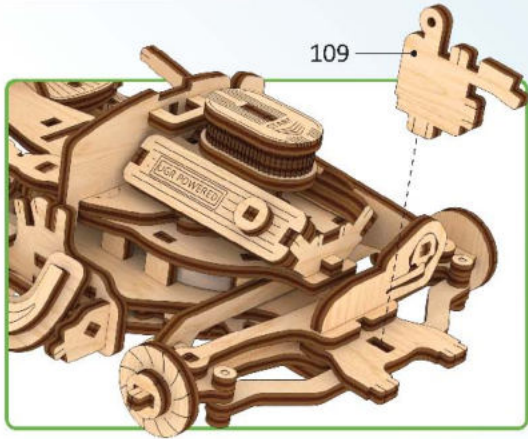

7

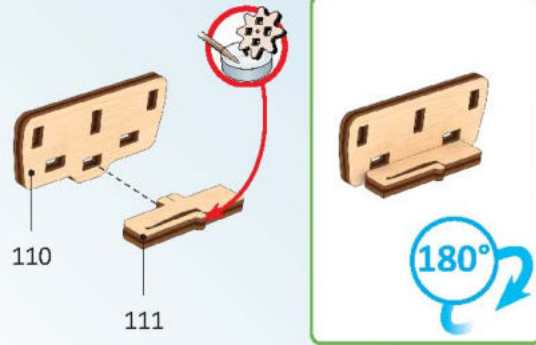

8

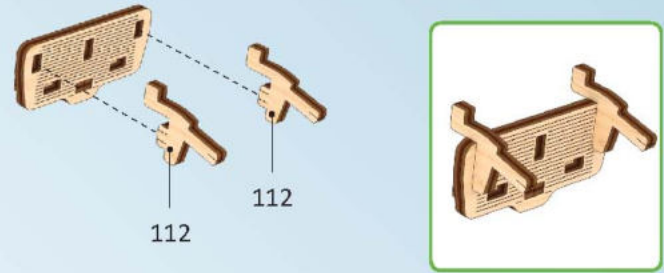

9

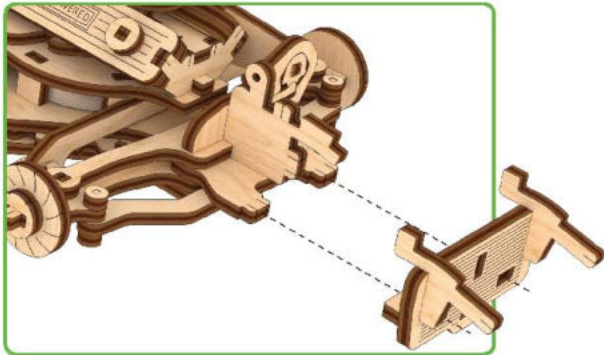

10

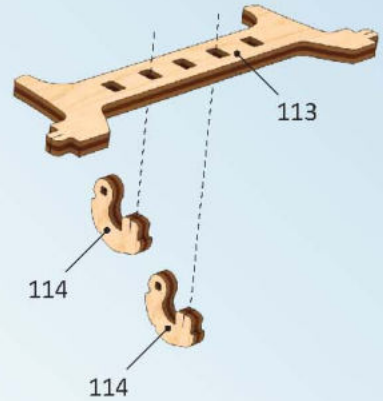

11

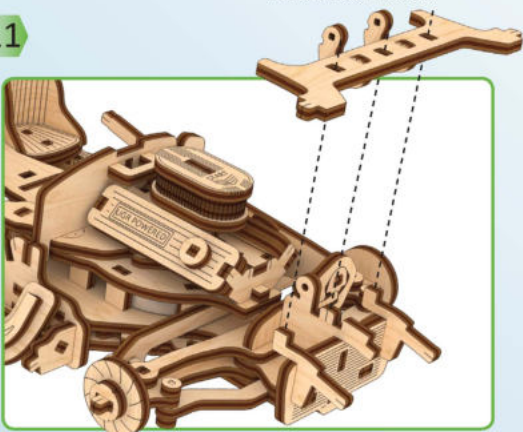

12

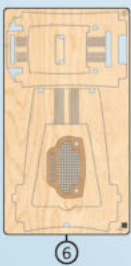
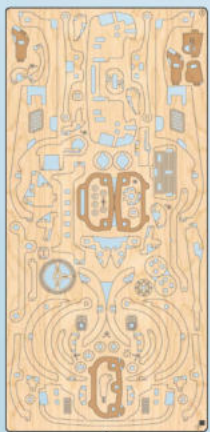
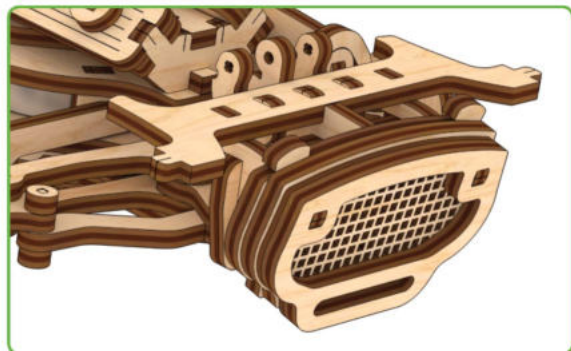
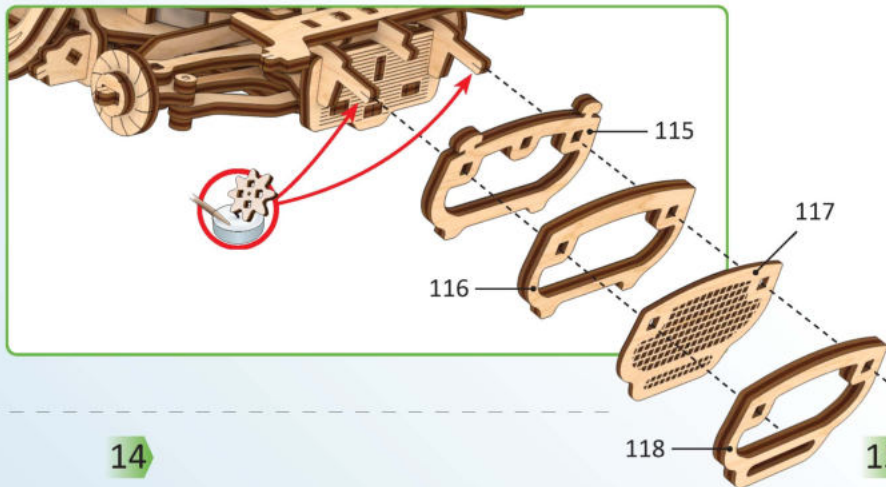

13

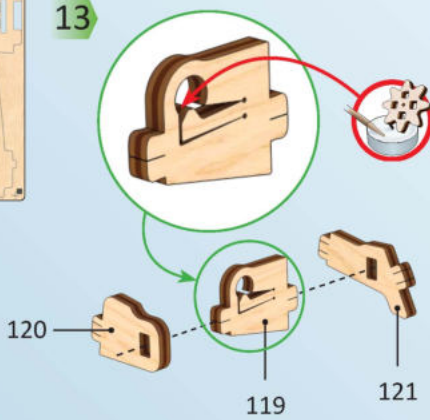

14



15

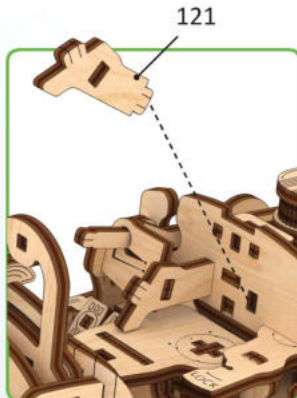

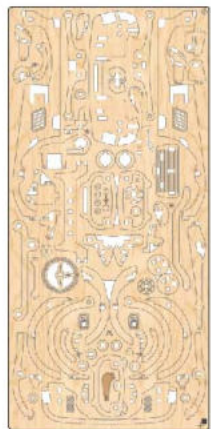

3

16

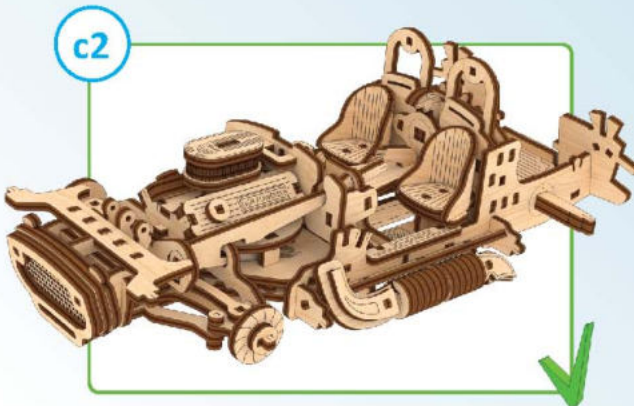
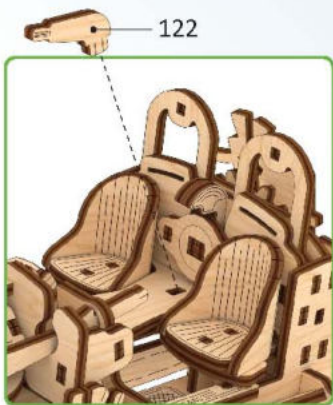

1

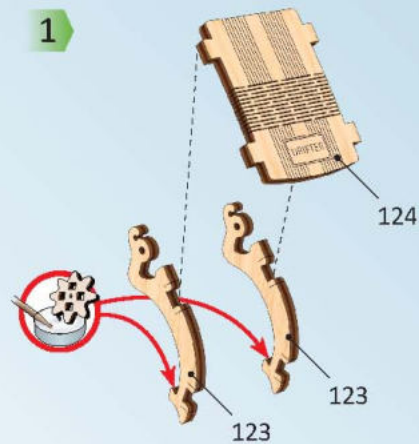

2

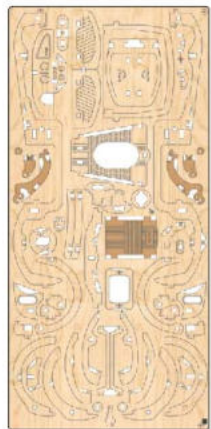
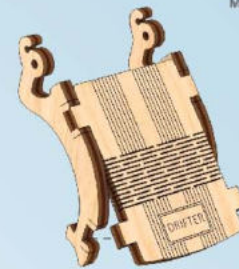

4

3

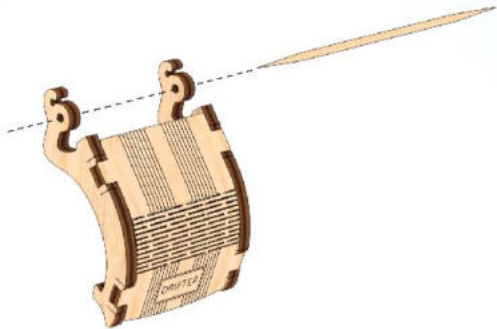

4

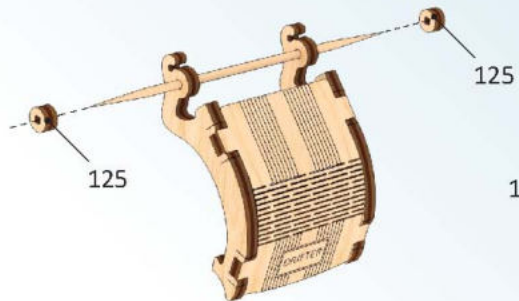

5

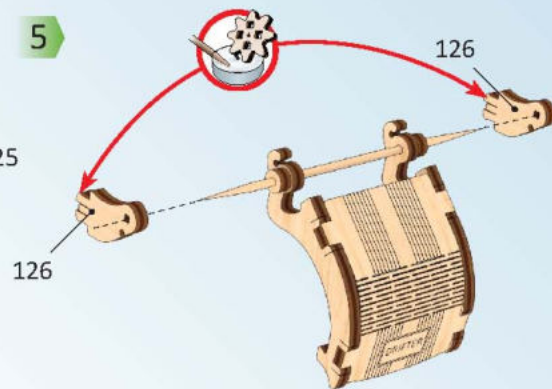

6

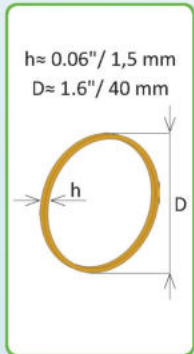
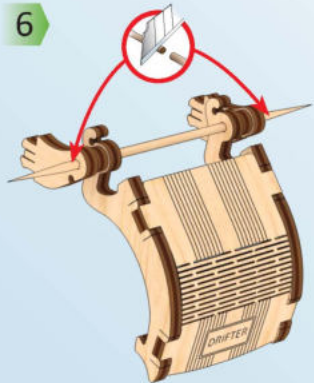

7

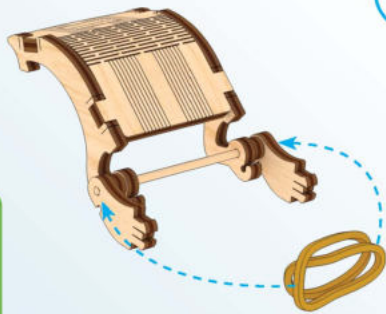

c3

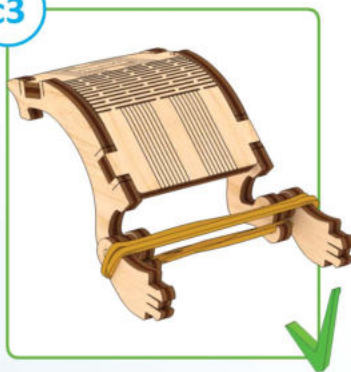

1

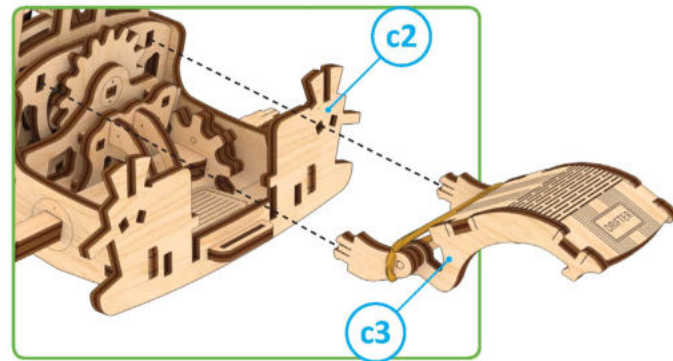

2

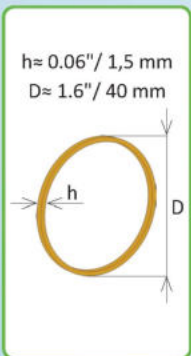

1

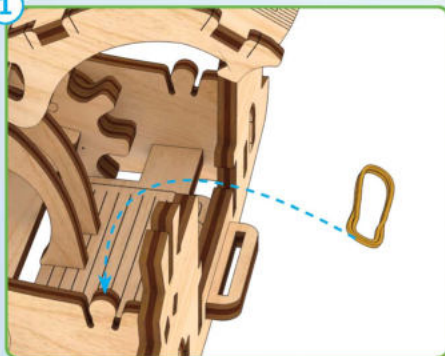

2

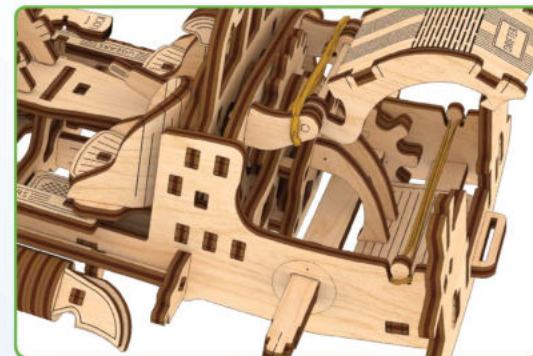
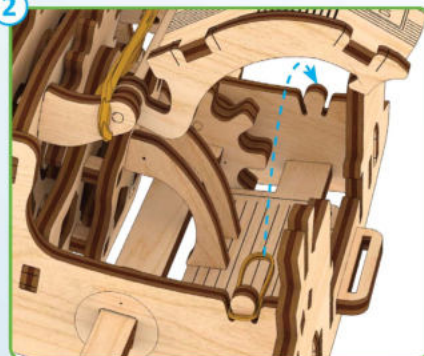

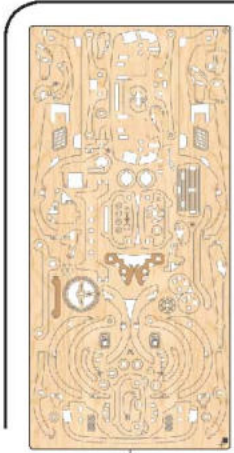

3

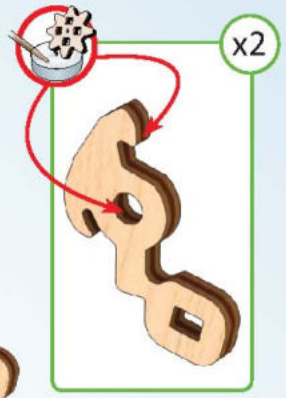
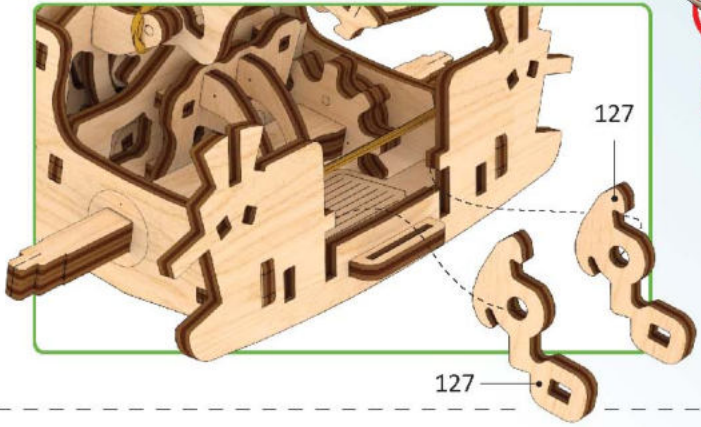

4

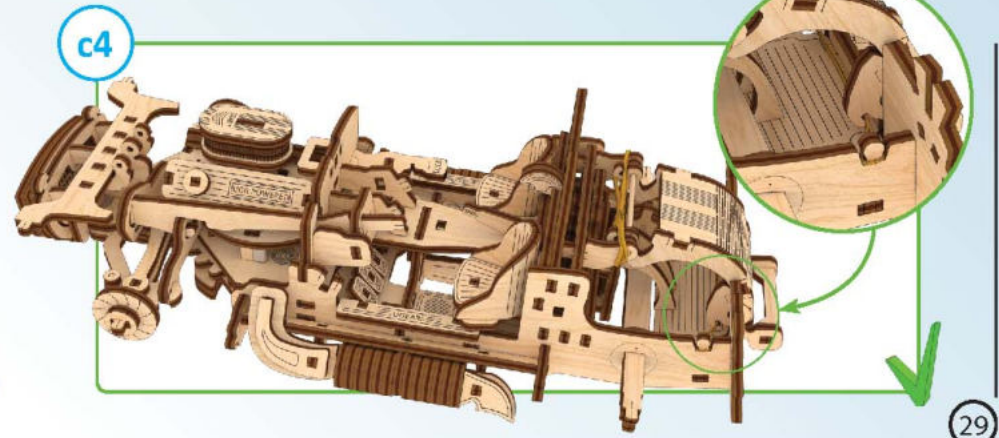
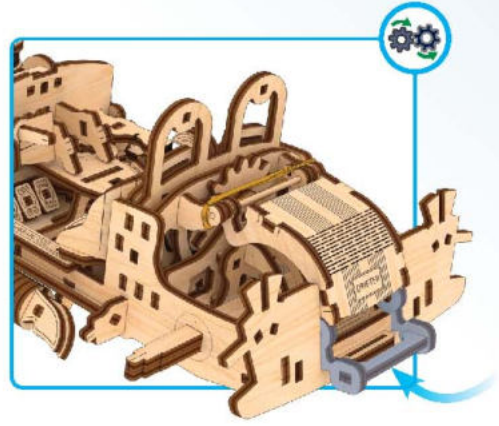
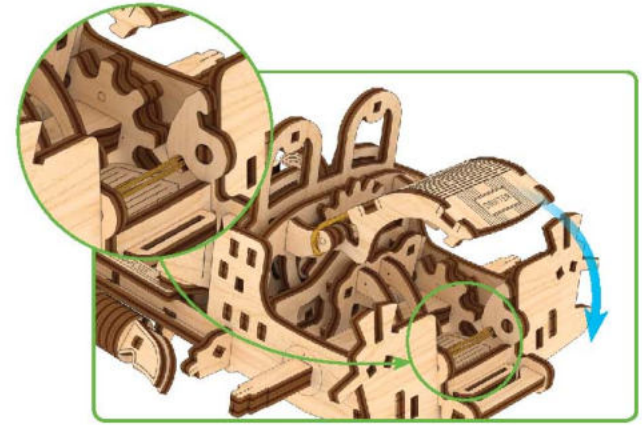
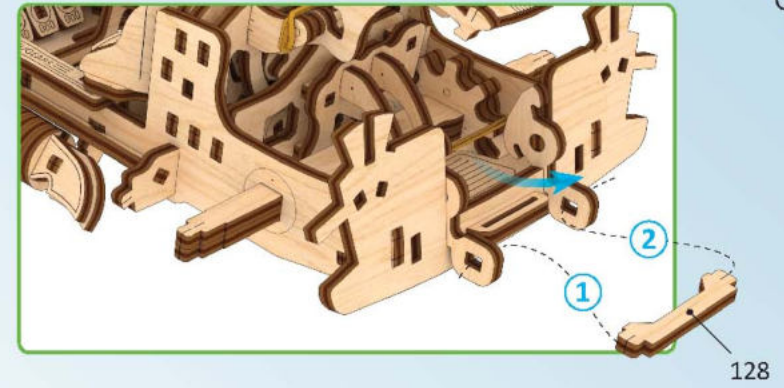

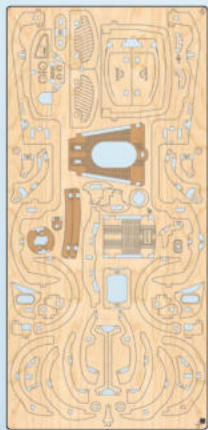

1

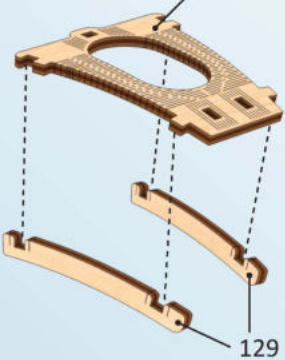

2

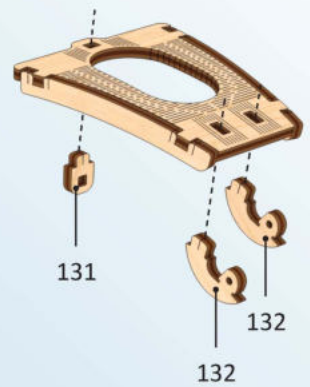

c5

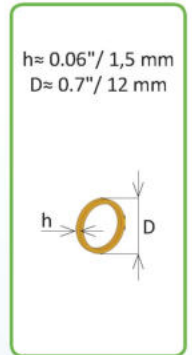

1

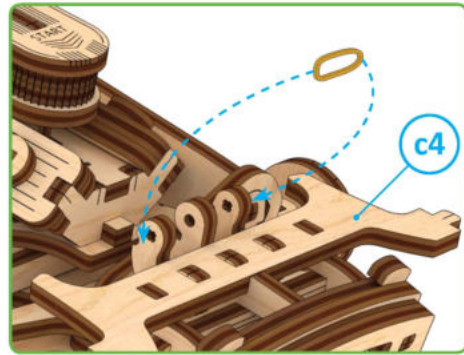

2

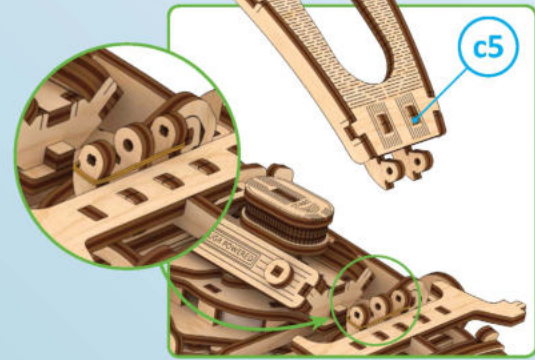

3

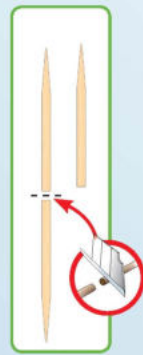

4

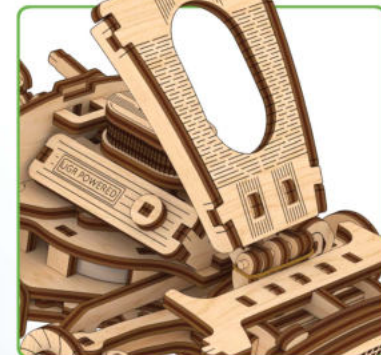
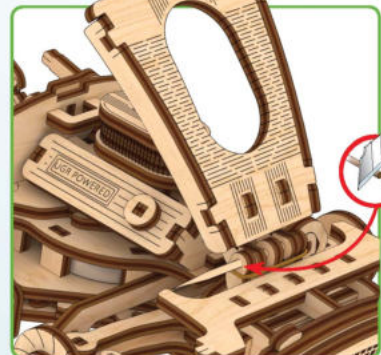

5

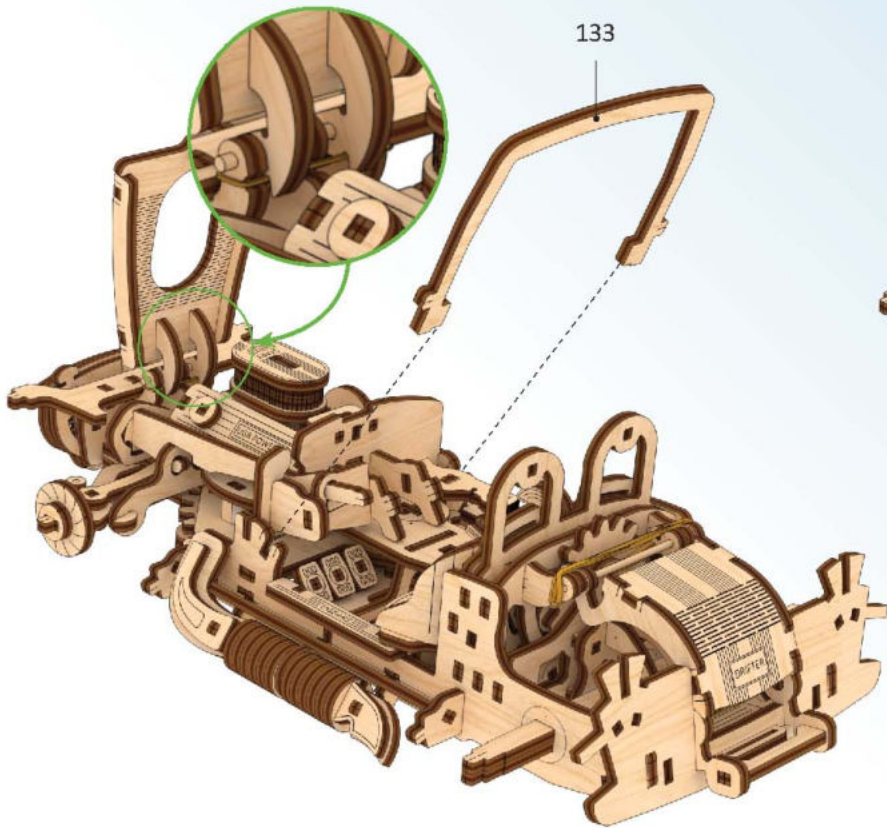
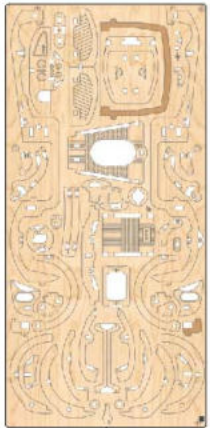

6

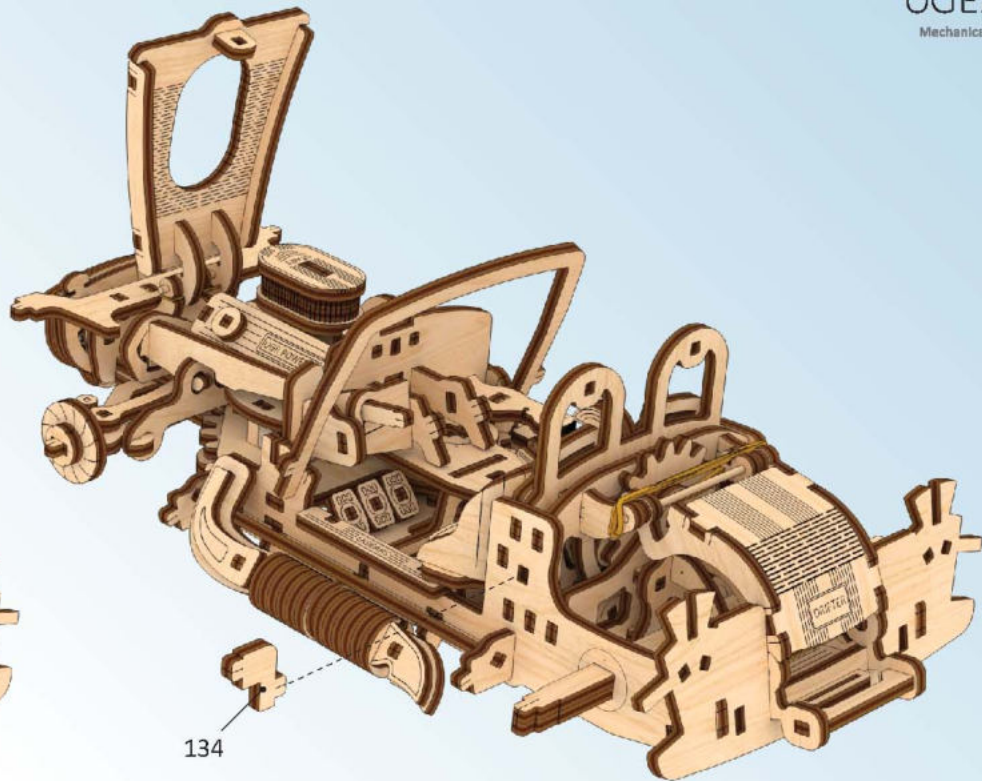

7

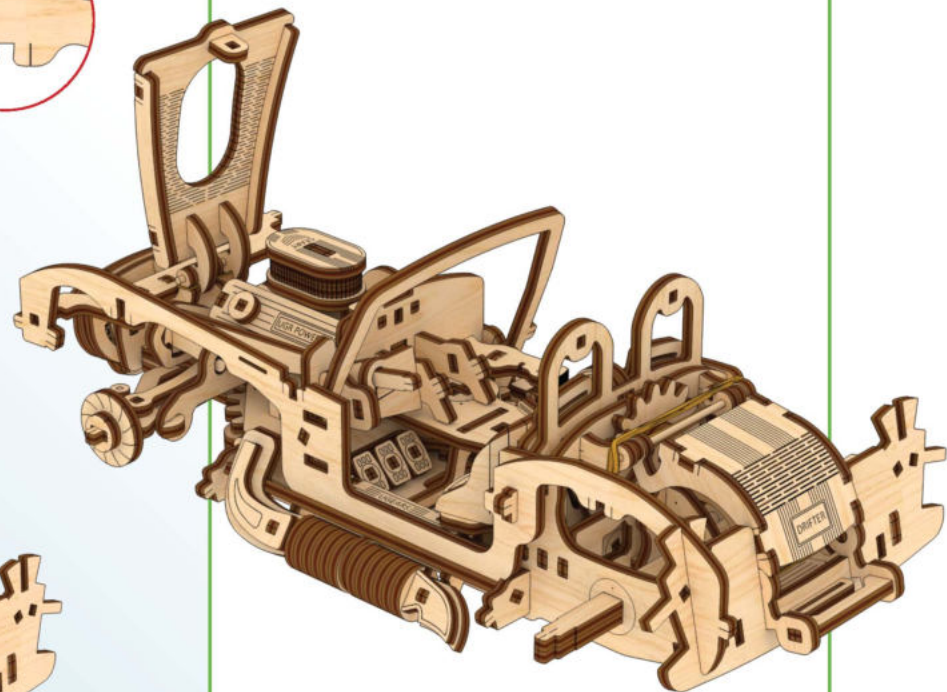
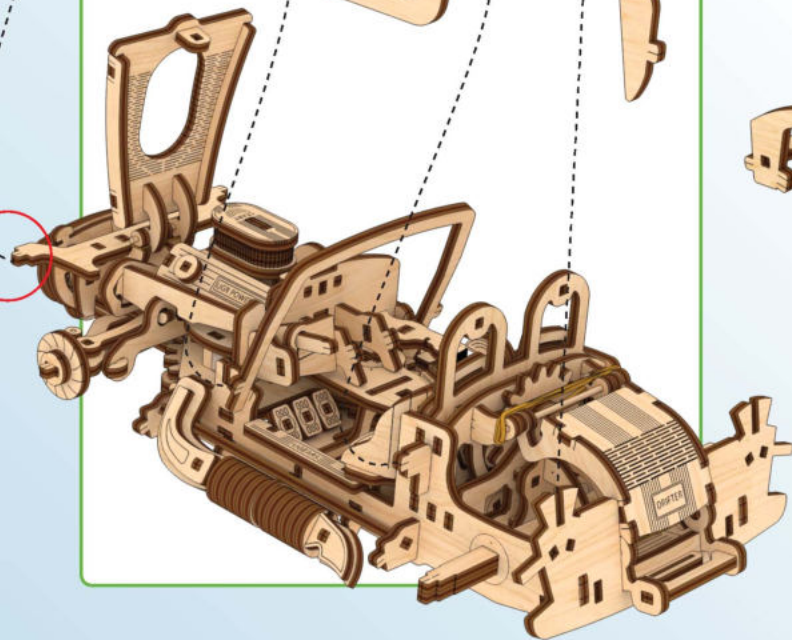
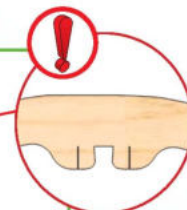
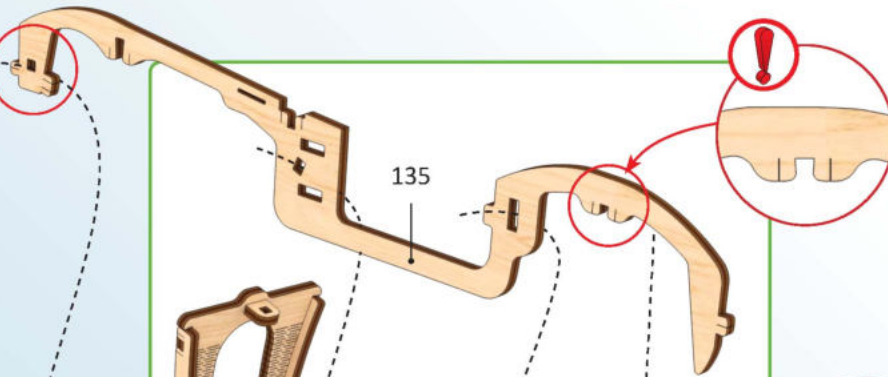
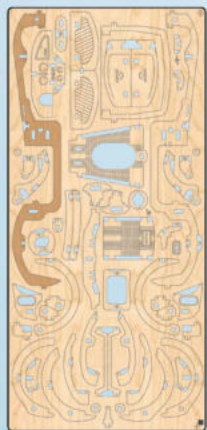

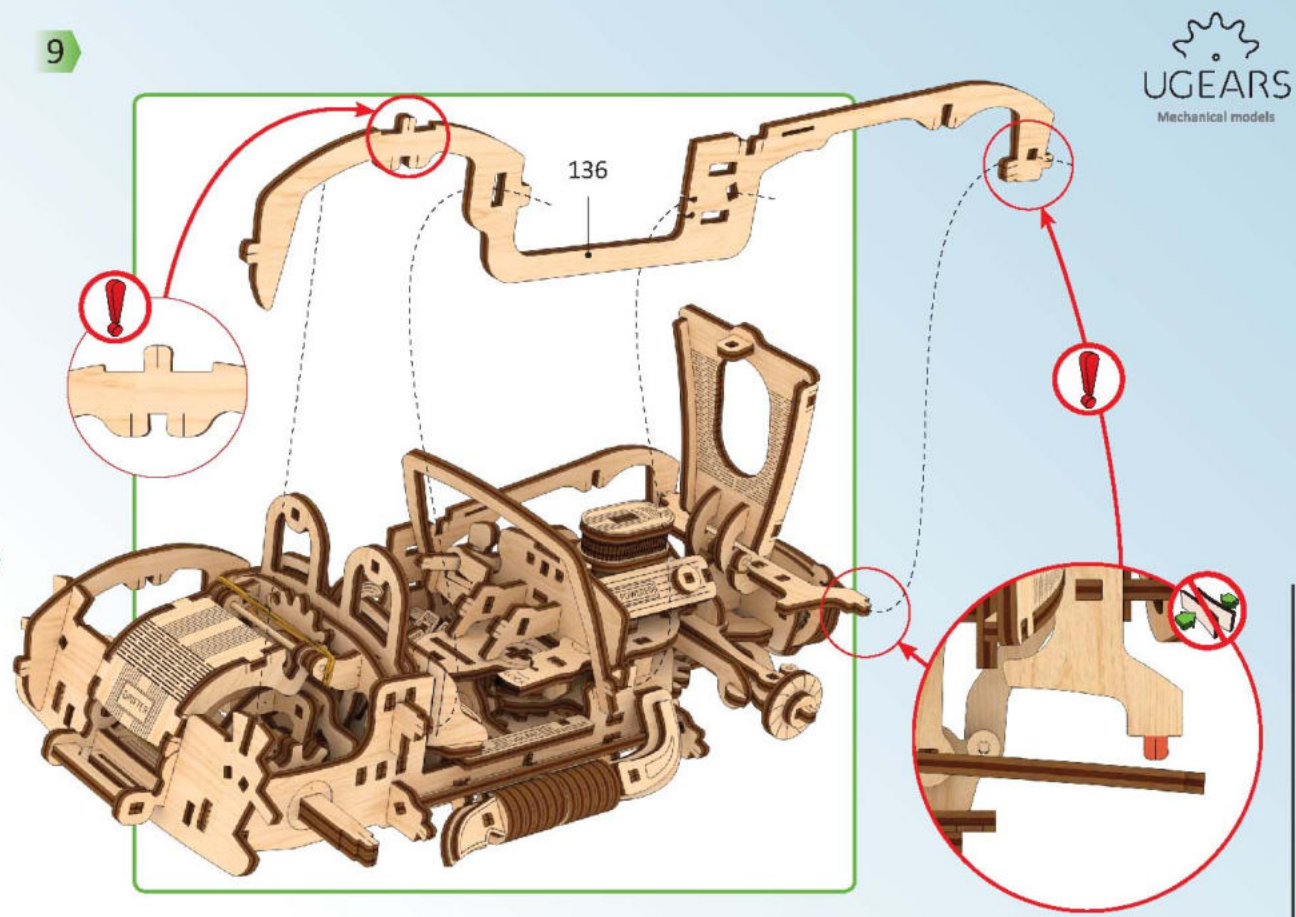
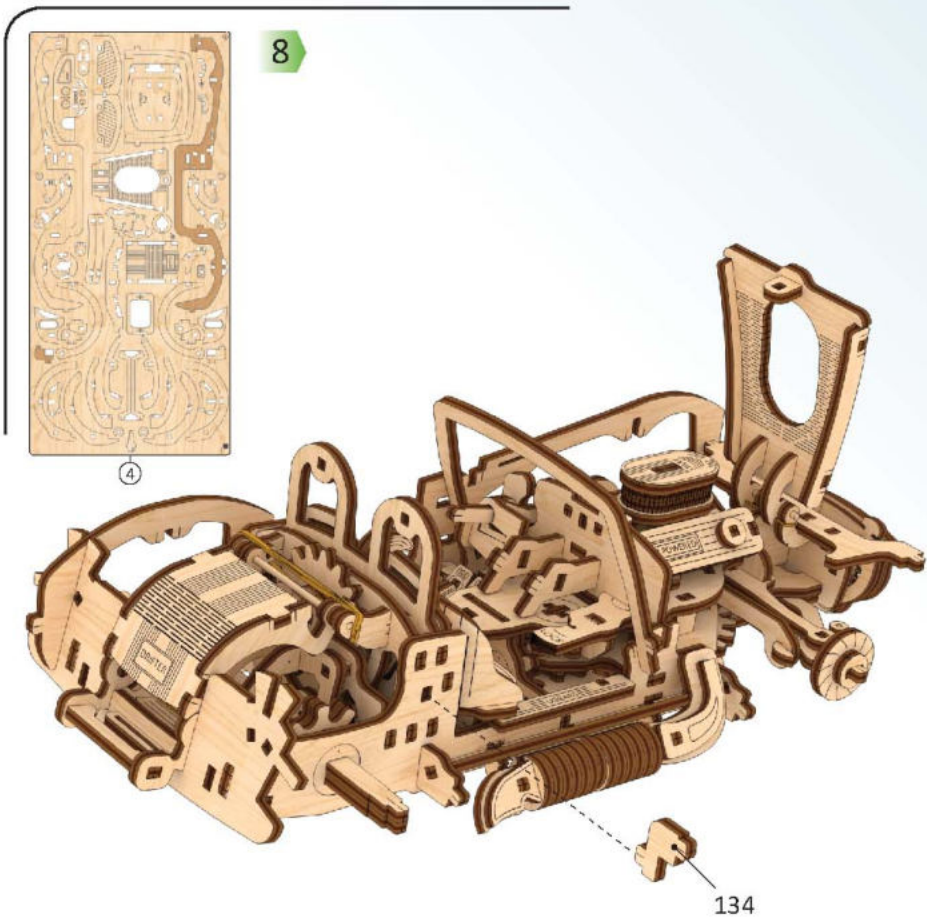

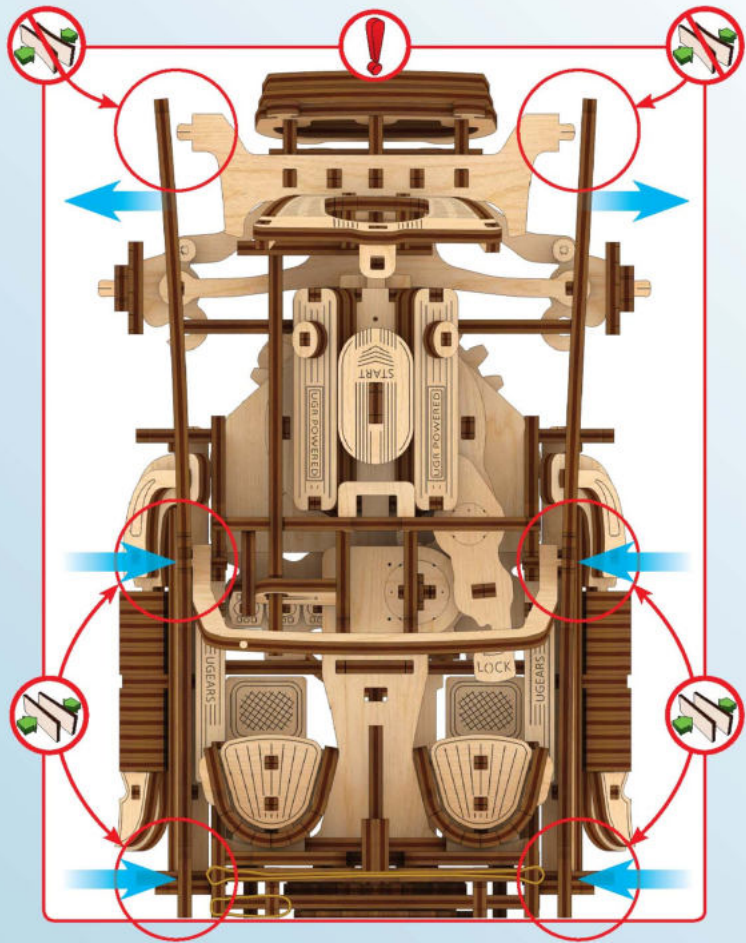

c6

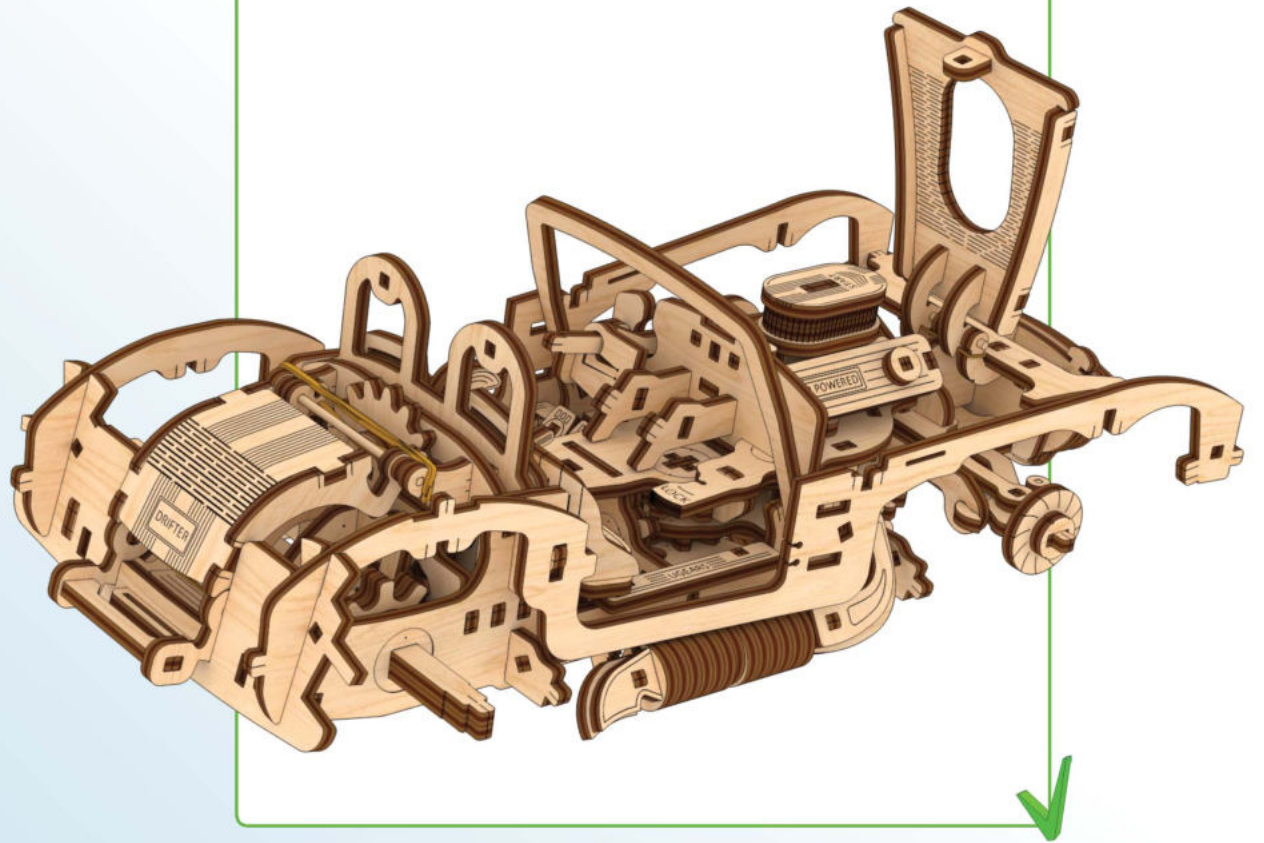

1

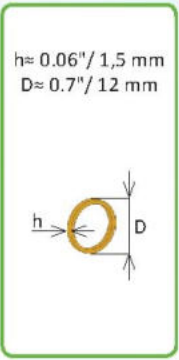
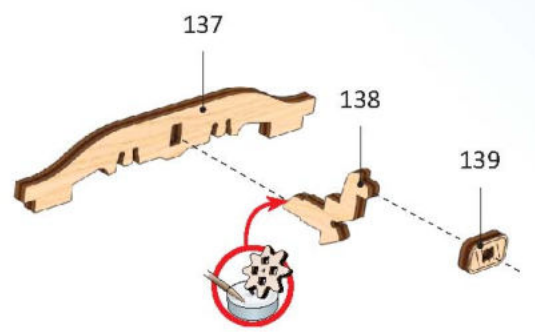

2

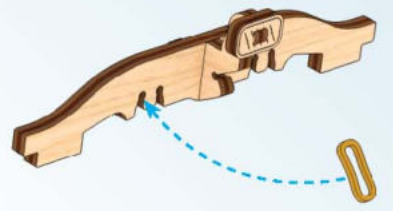

3

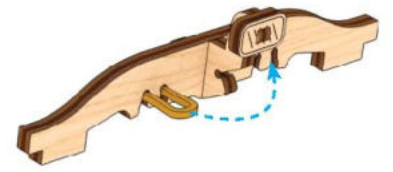

4

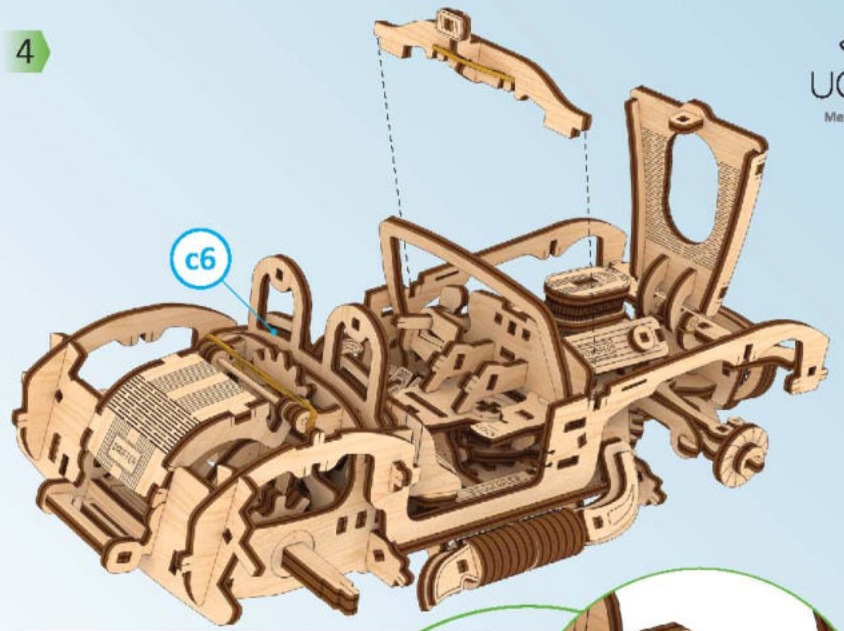

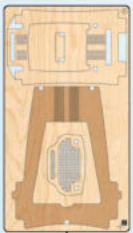
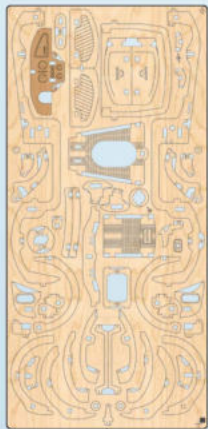

5



6

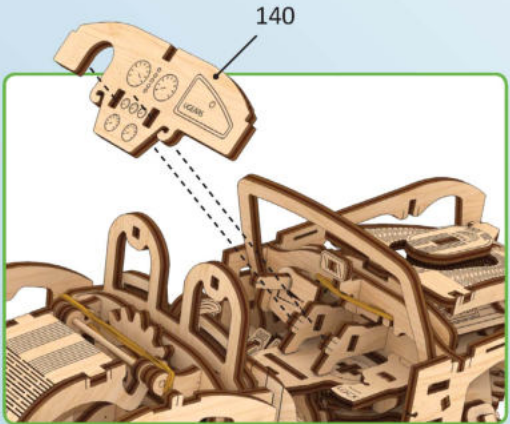

140

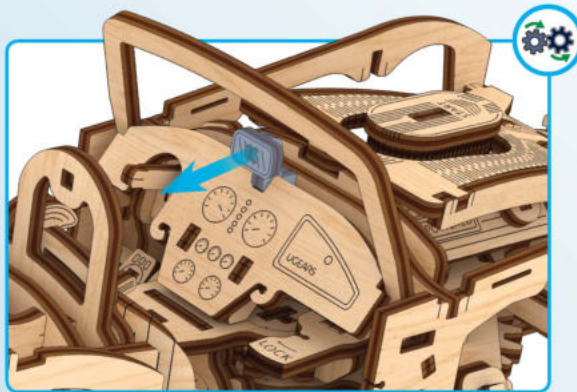

7

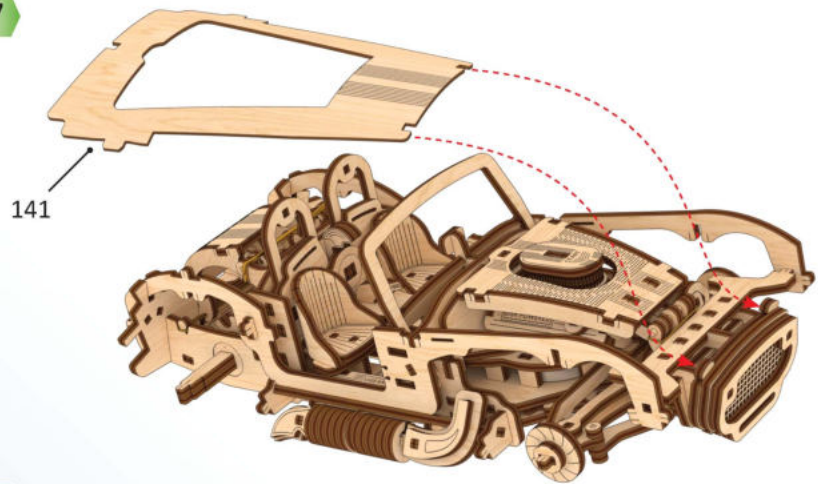

8

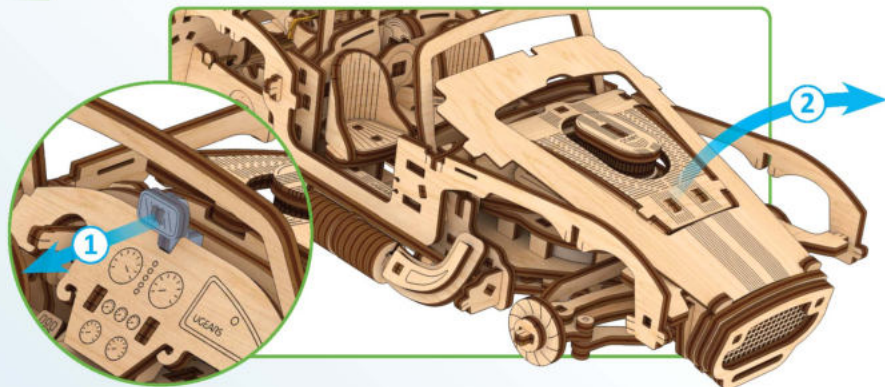

9

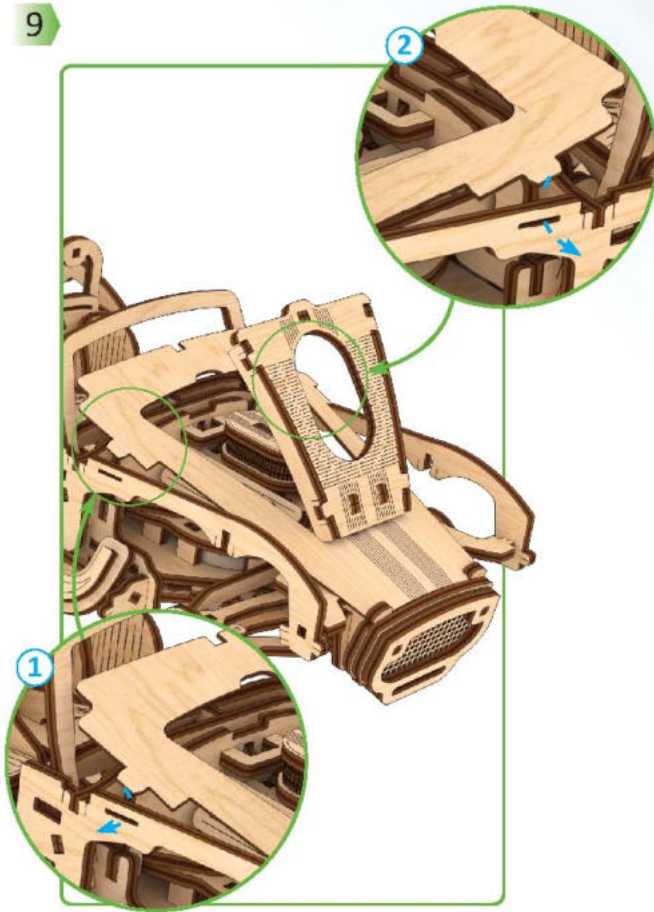

10

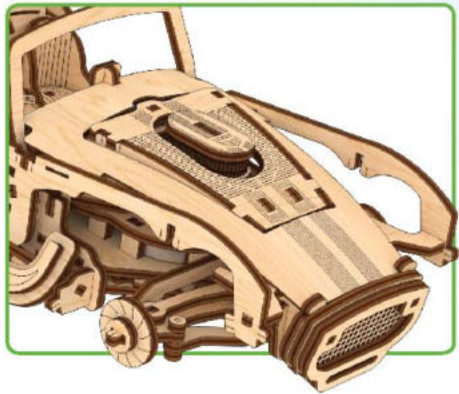
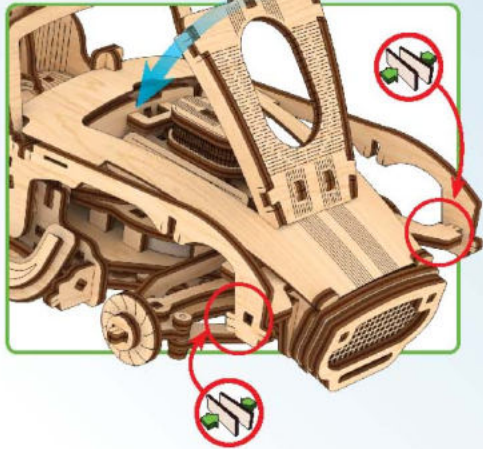

11

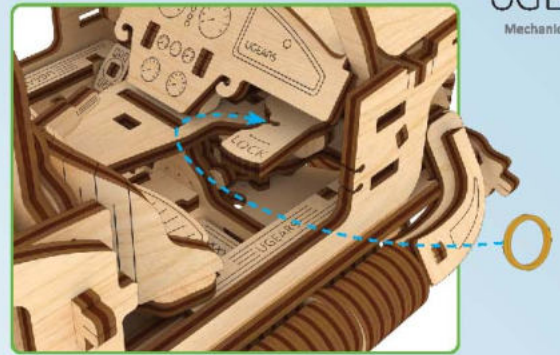
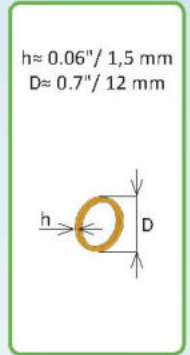

12

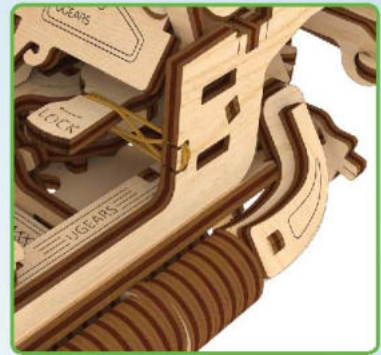
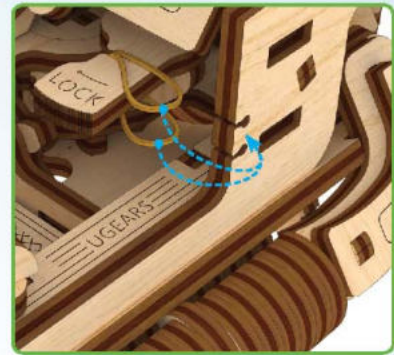

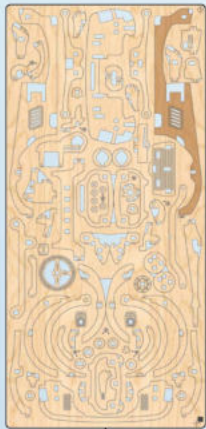

③

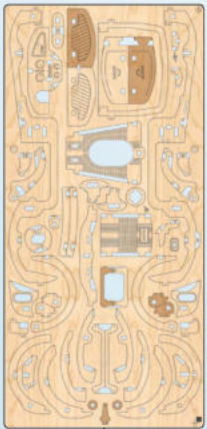

④

12

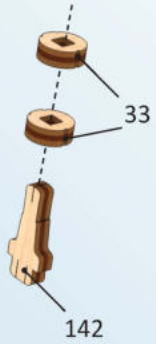

13



c7

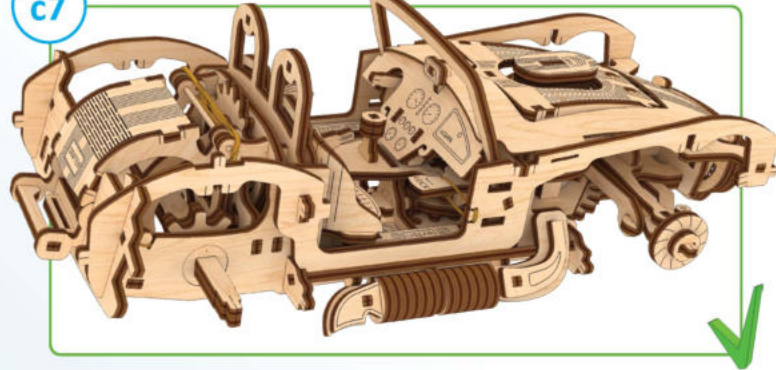

1

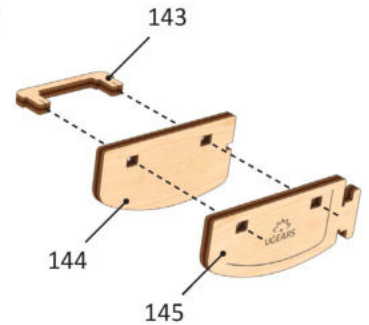

2

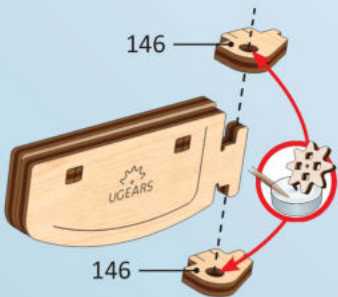

3

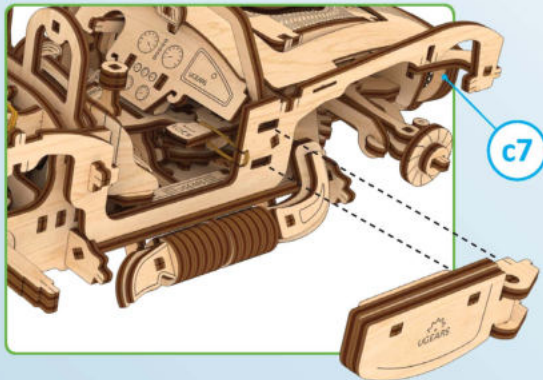

c7

4

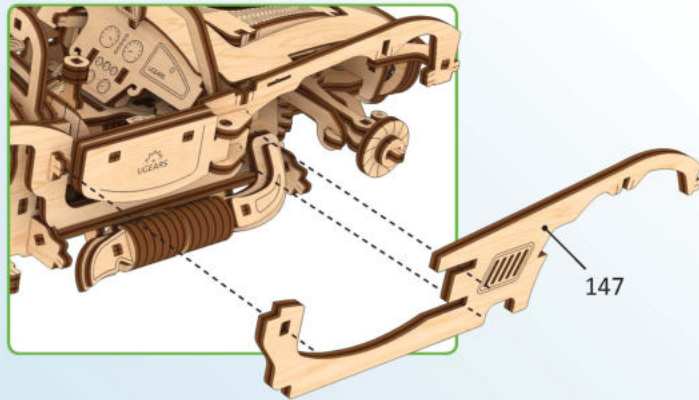

147

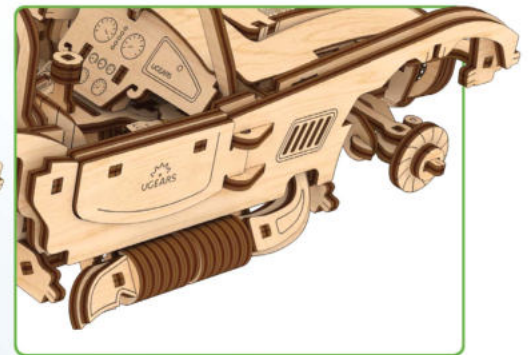

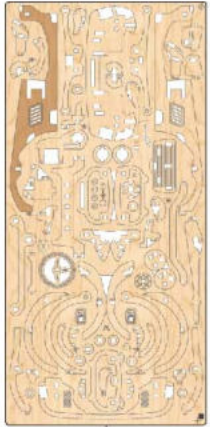

3

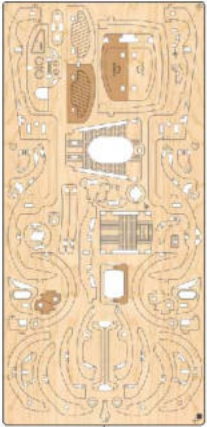

4

5

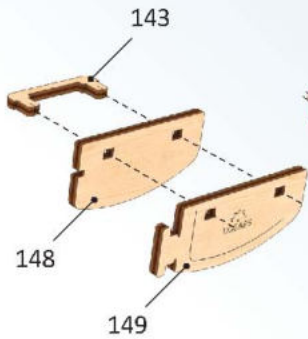

6

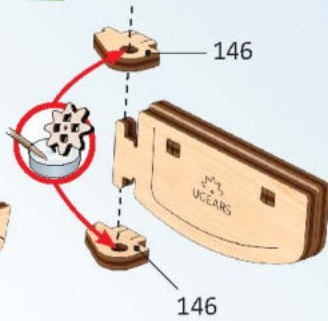

7

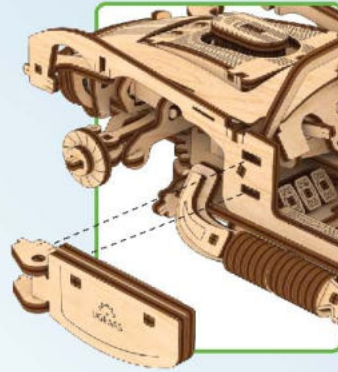

8

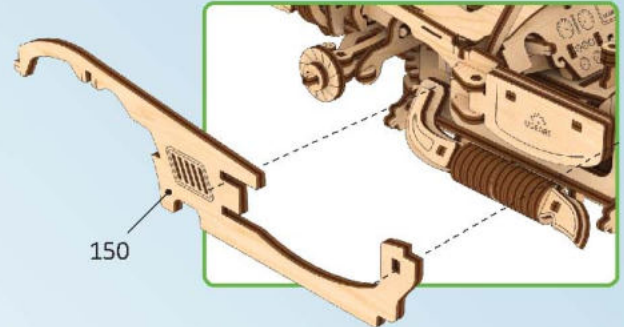

9

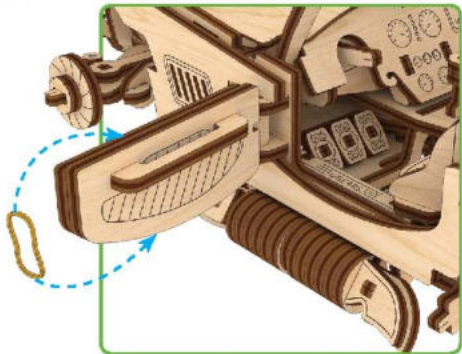
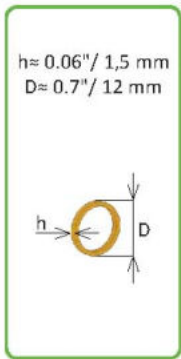

10

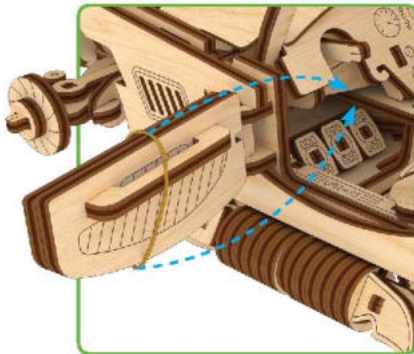

11

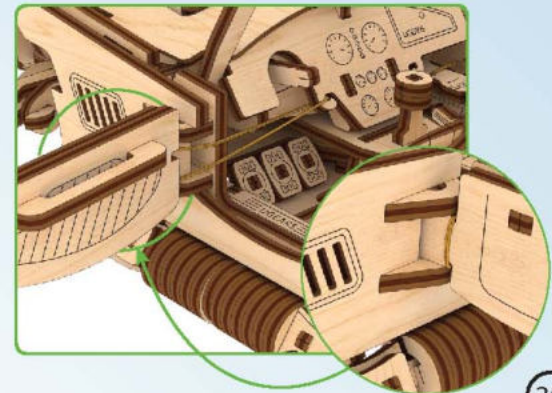
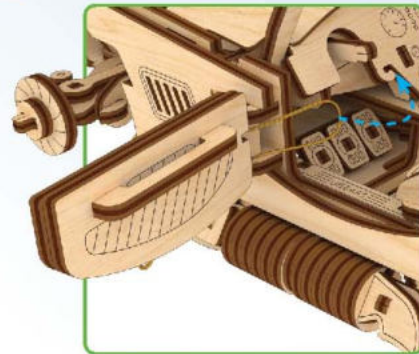

11

$h = 0.06'' / 1,5 \text{ mm}$
 $D = 0.7'' / 12 \text{ mm}$

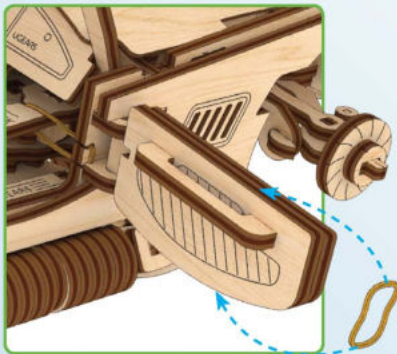
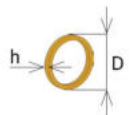

12

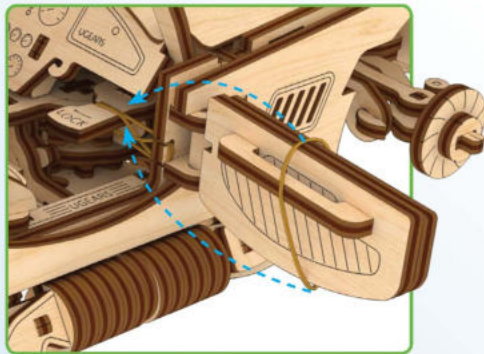

13

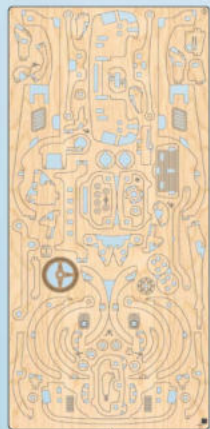
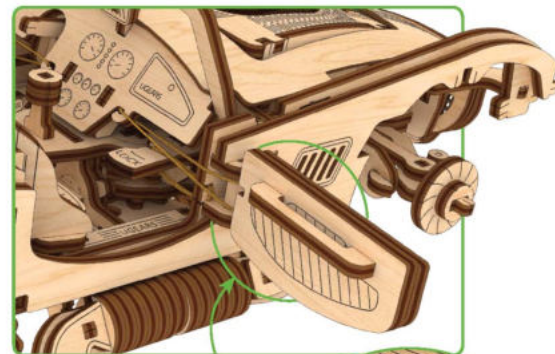
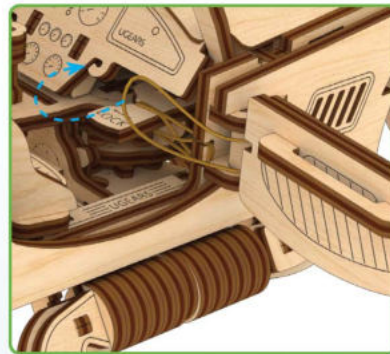

14

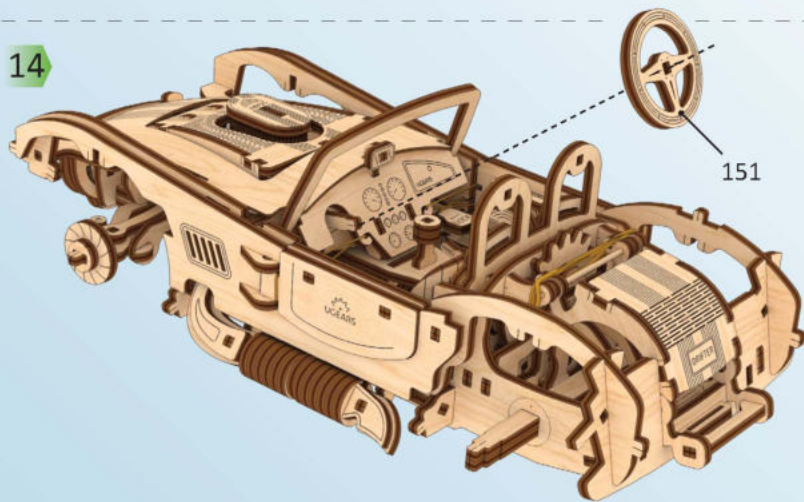

c8

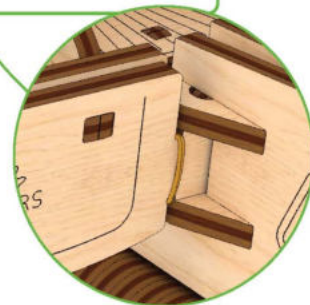
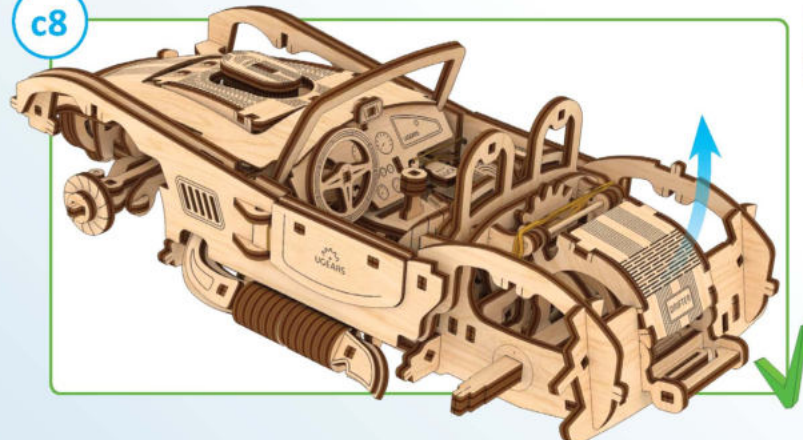

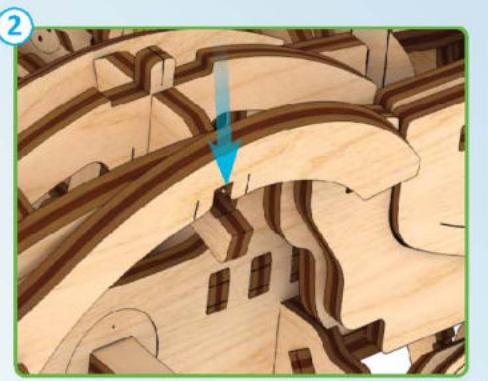
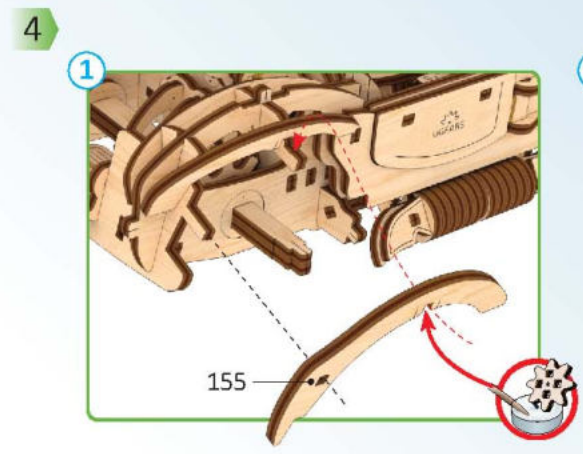
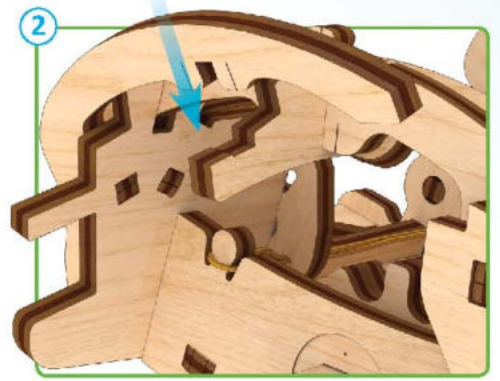
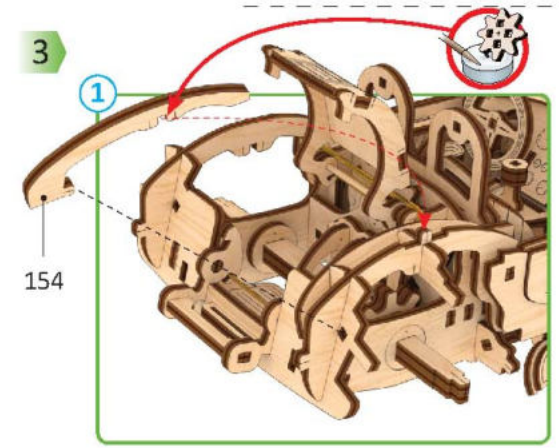
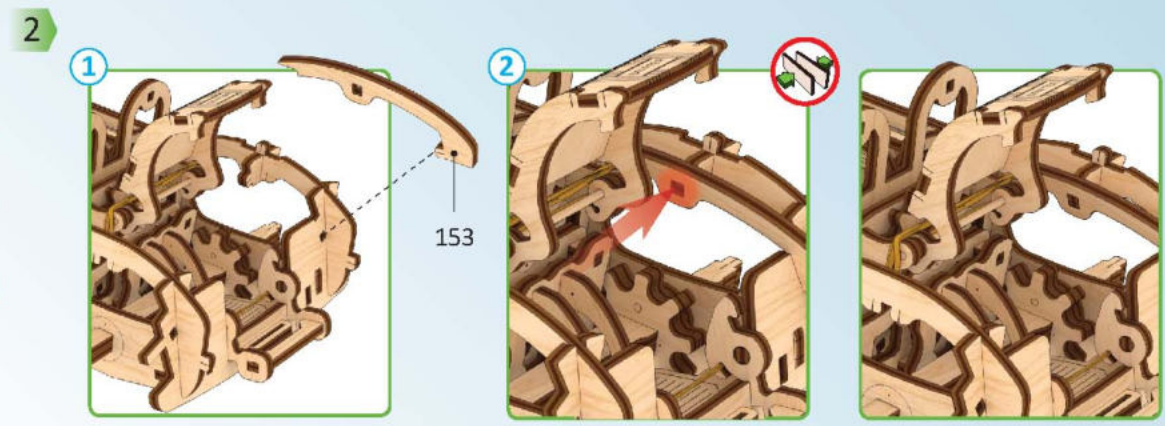
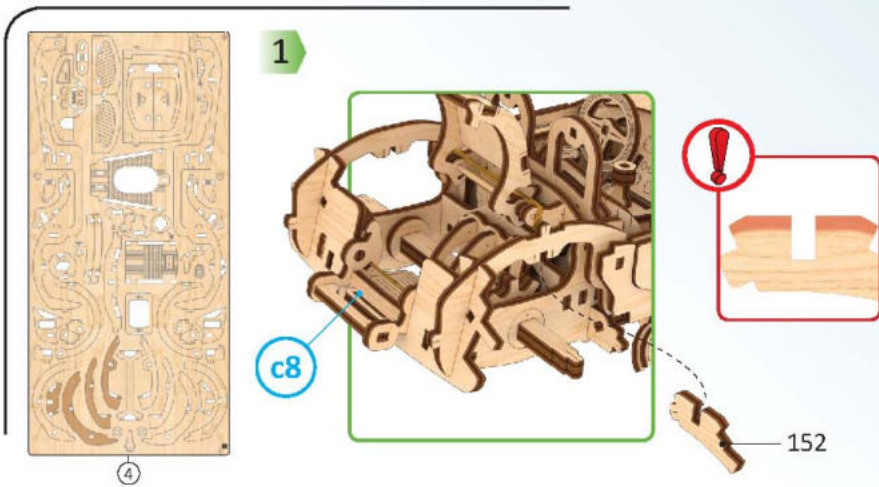

5

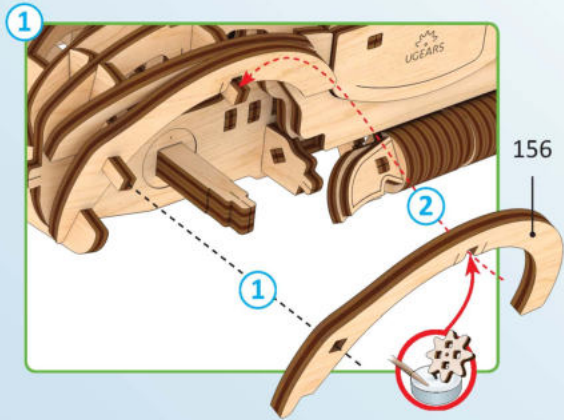

2

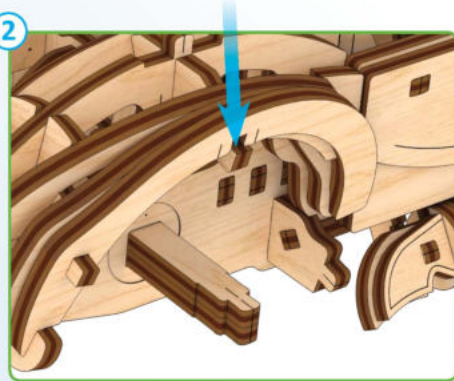

6

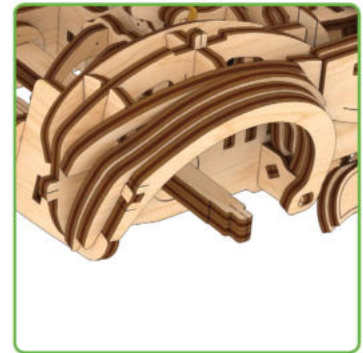
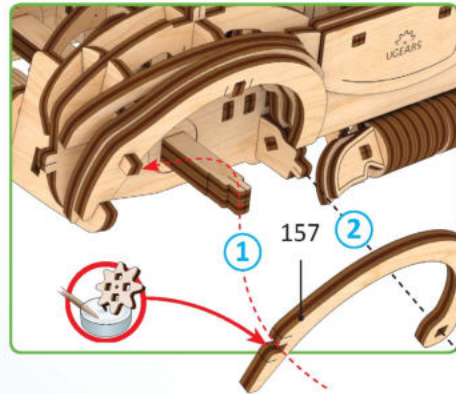

7

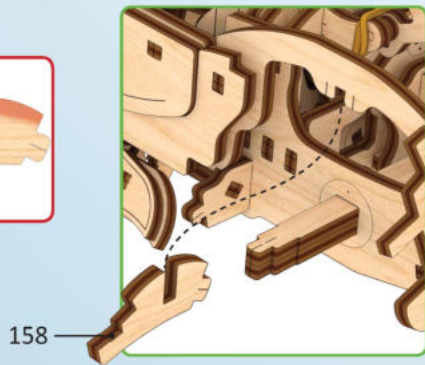
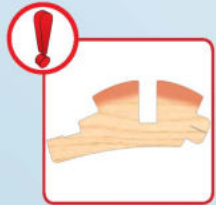
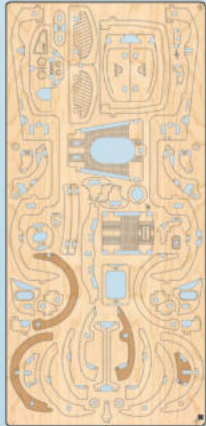

8

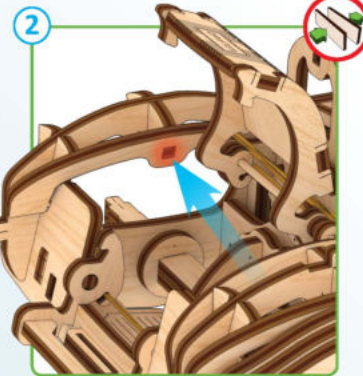
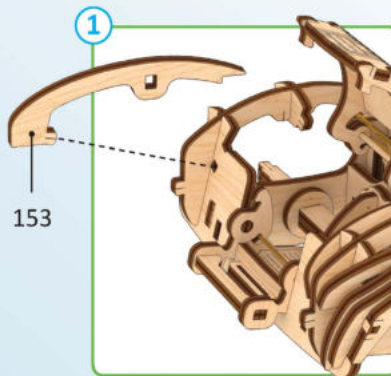

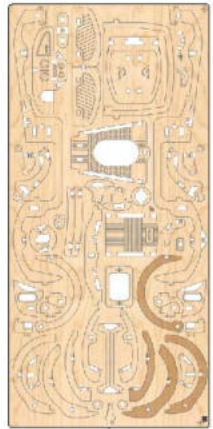

9

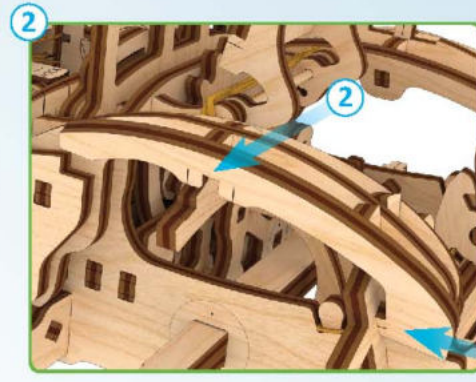
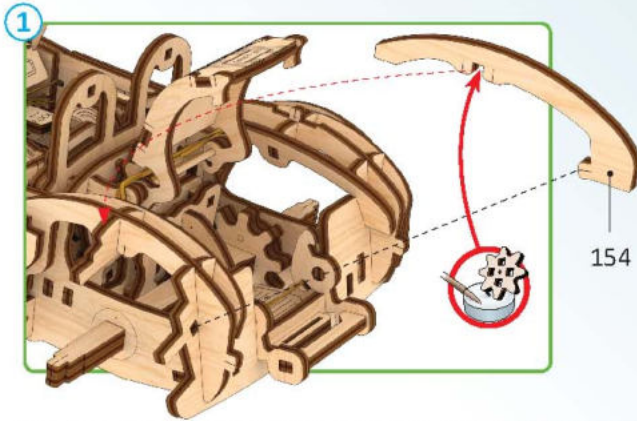

10

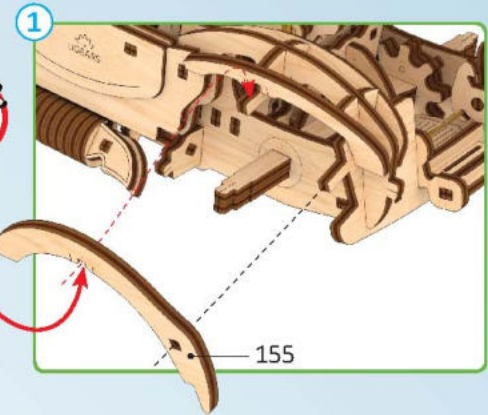

11

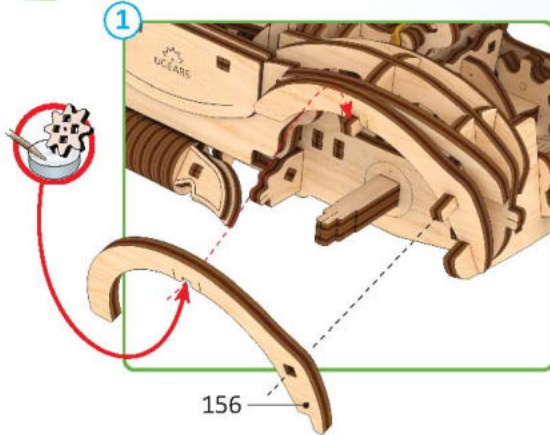
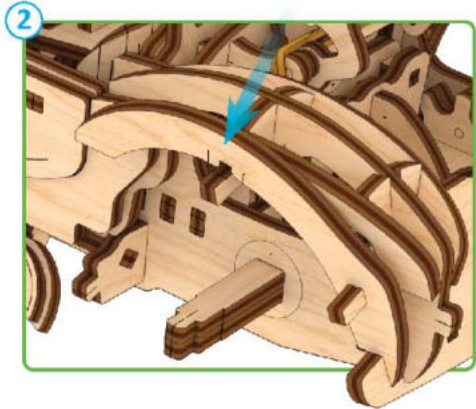

12

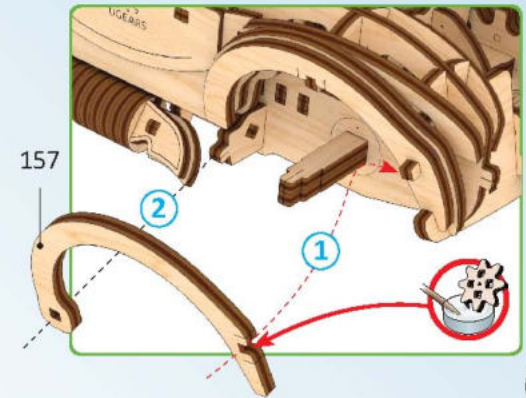
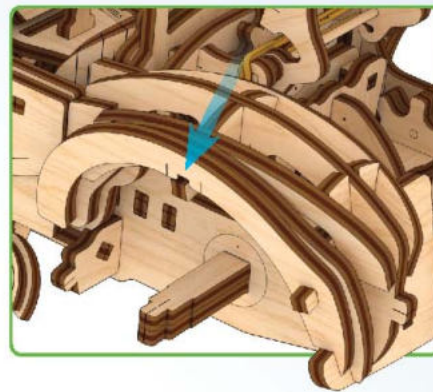

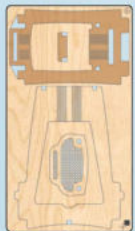
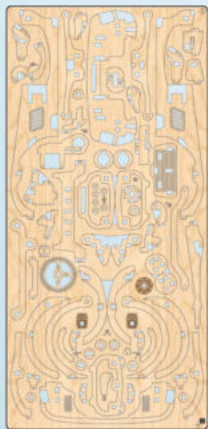

13

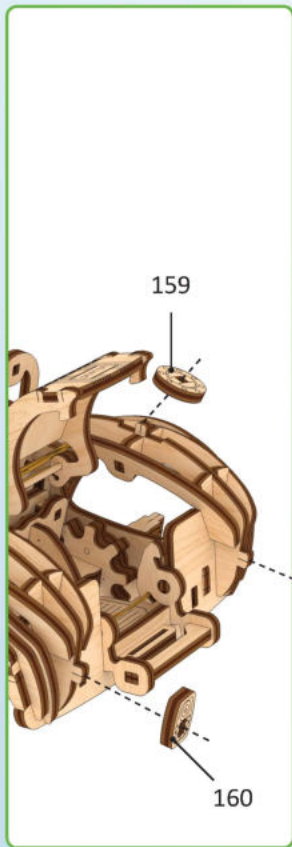

14

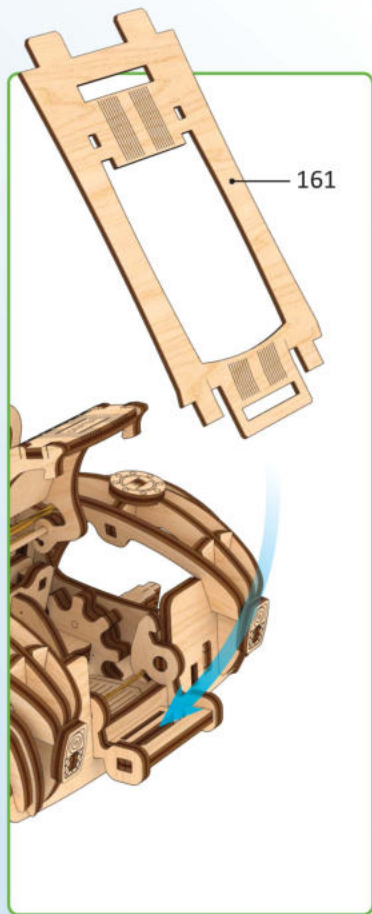

15

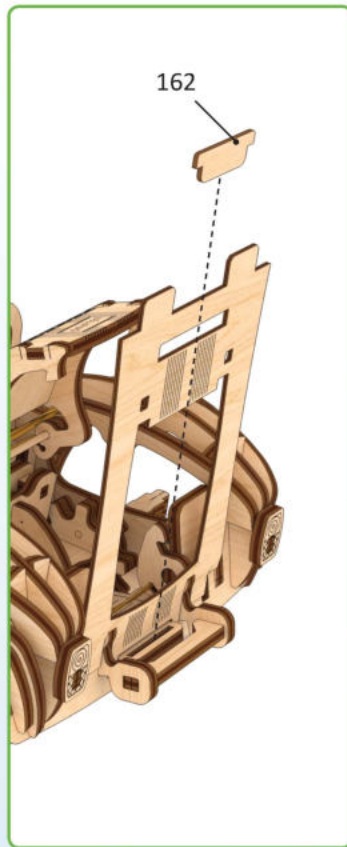

16

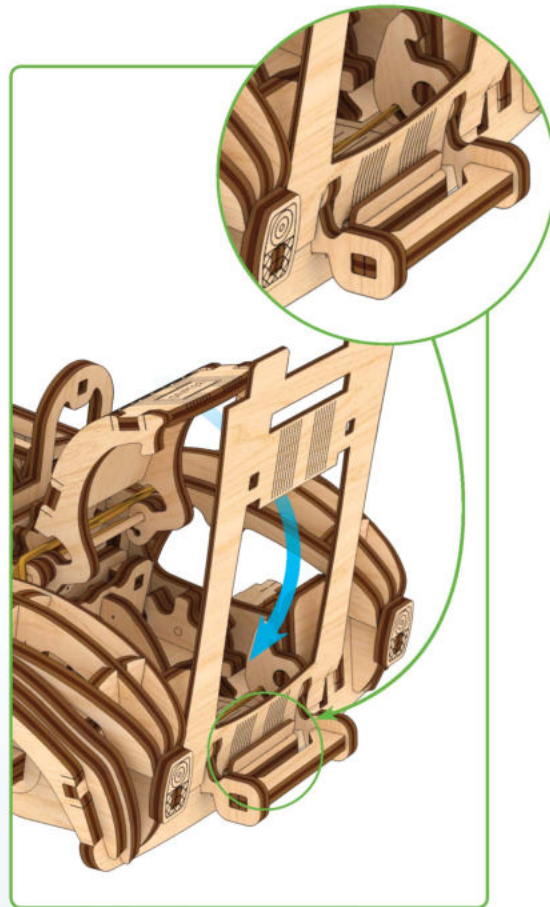

17

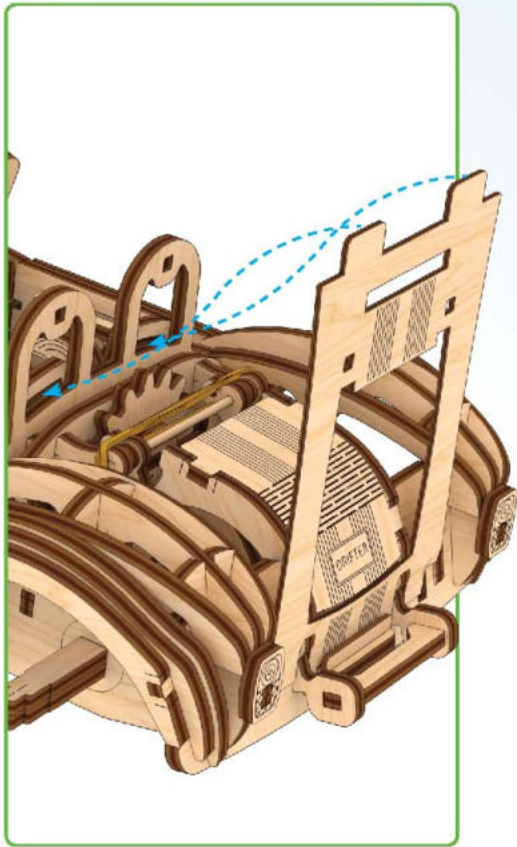
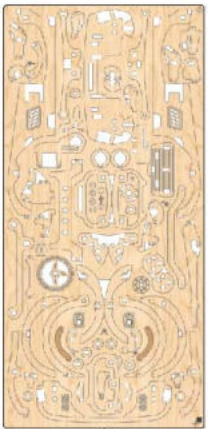

18

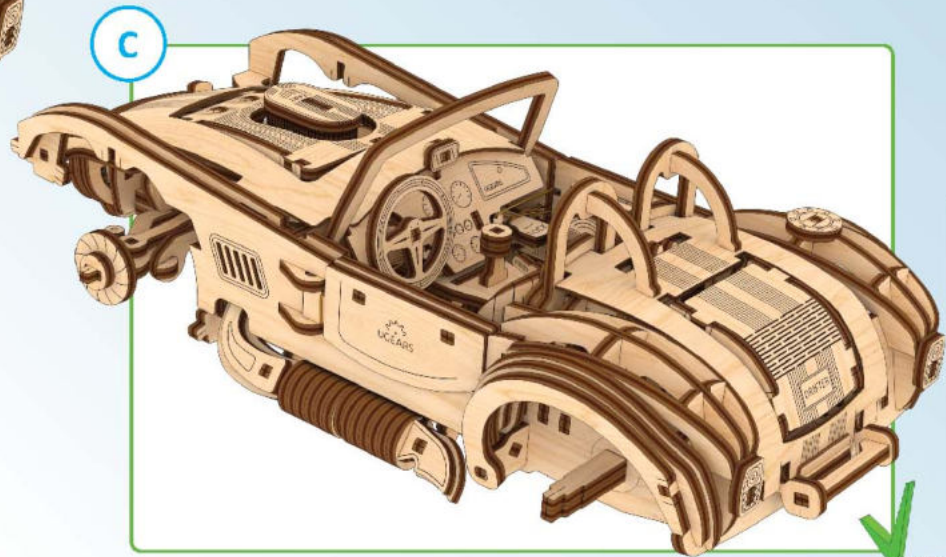

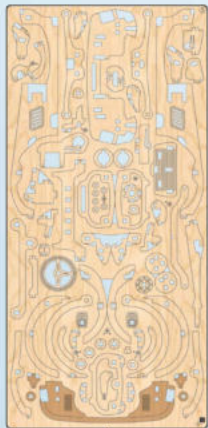

3

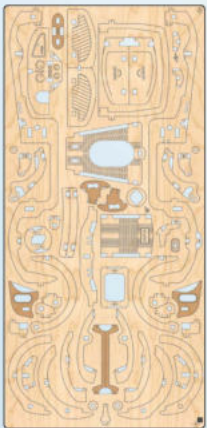

4

1

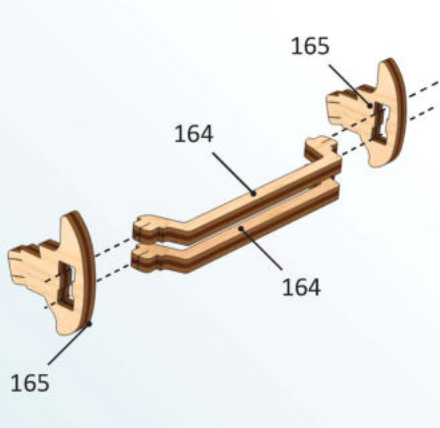

2

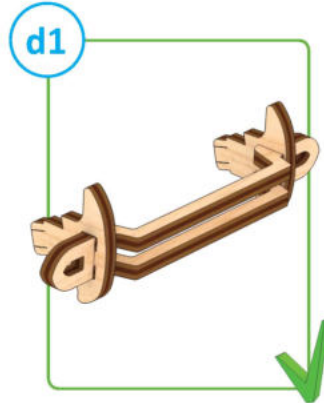
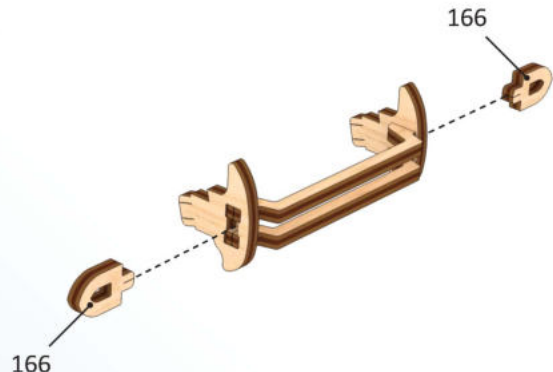

1

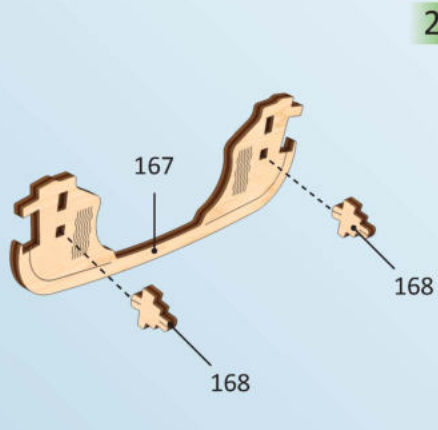
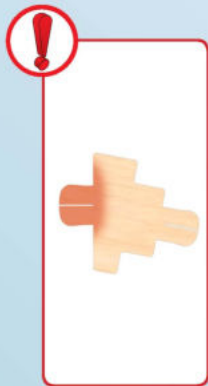

2

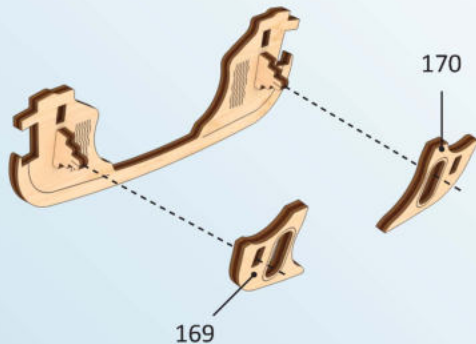

3



1

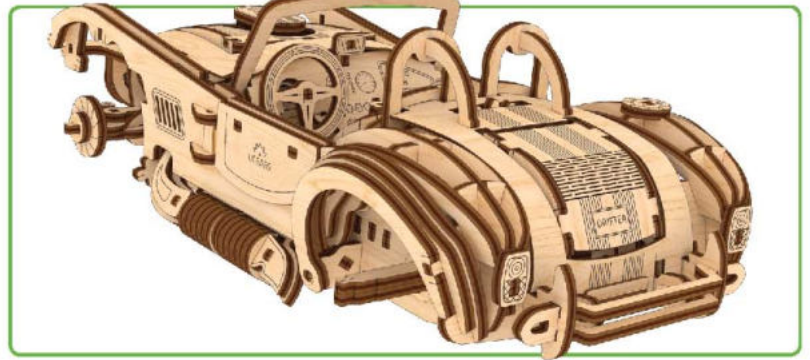
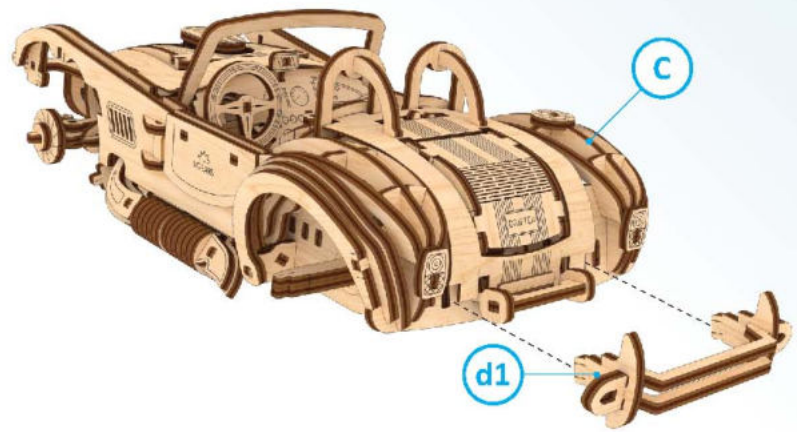

2

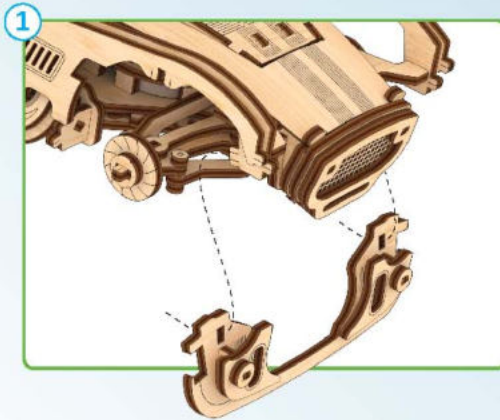

D

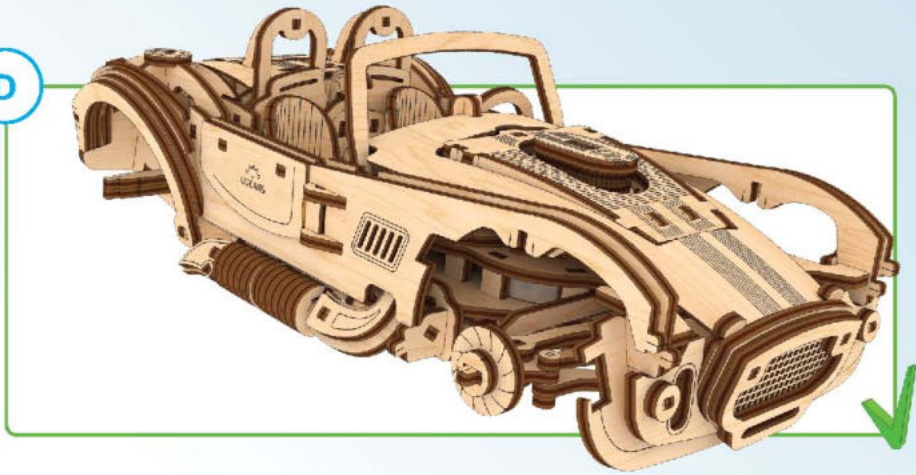

1

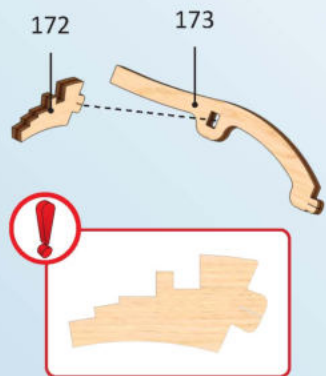

2

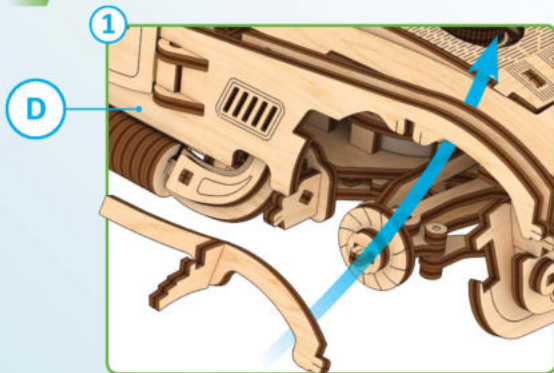

2

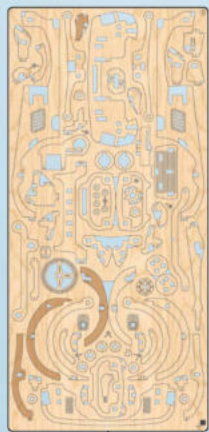
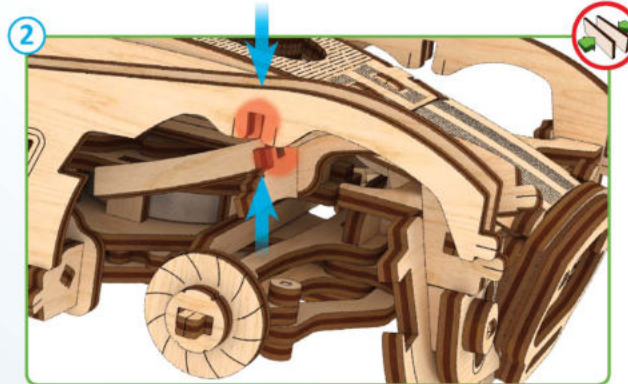

3

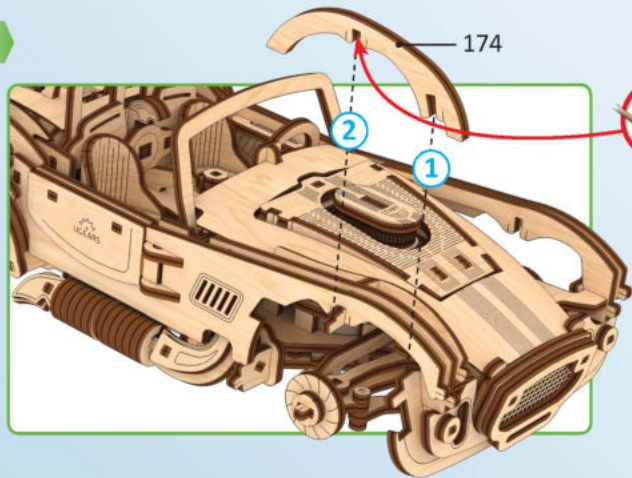

4

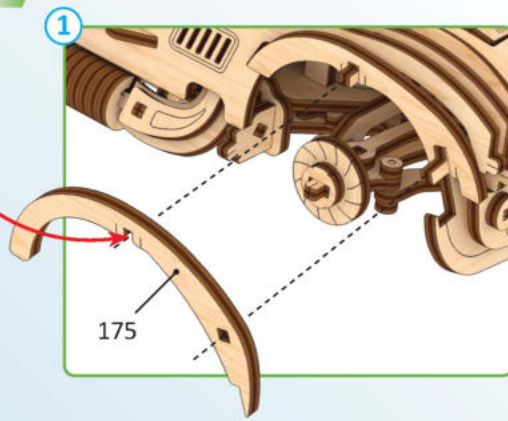

2

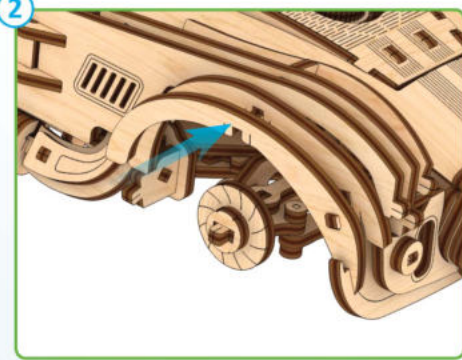

5

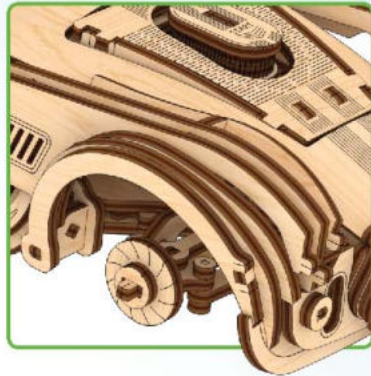
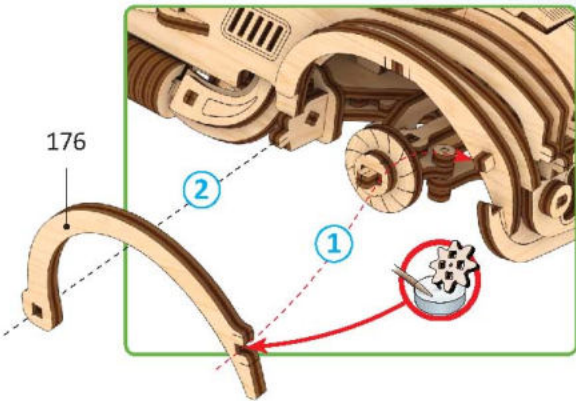

6

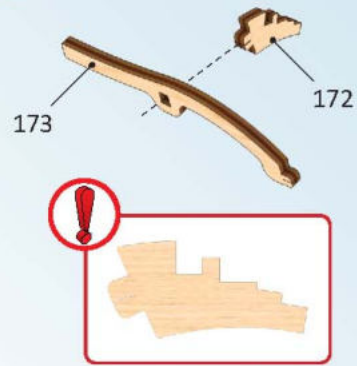

7

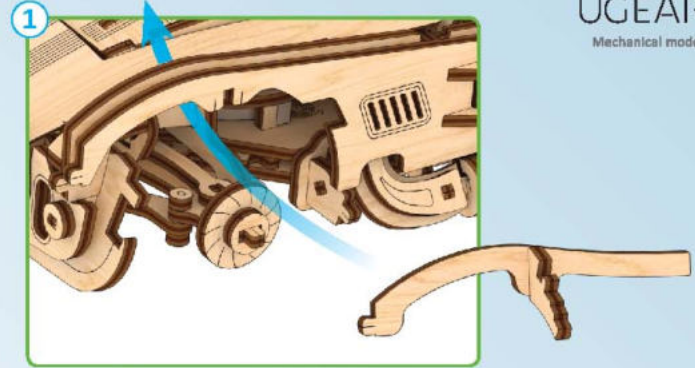

3

2

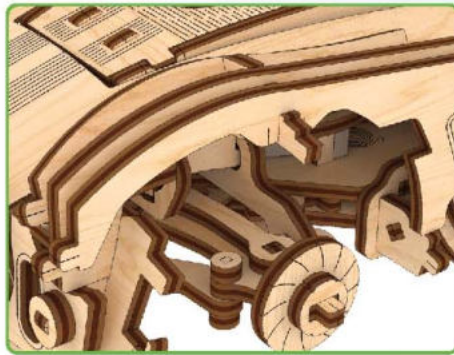
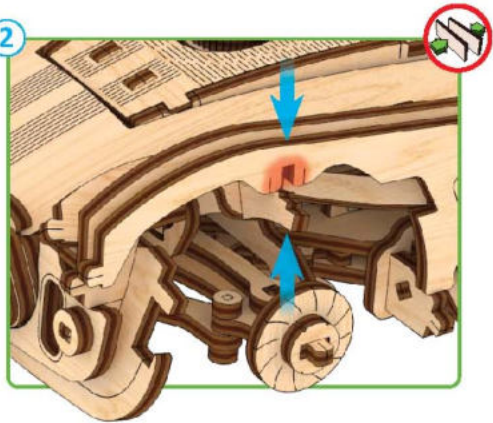

8

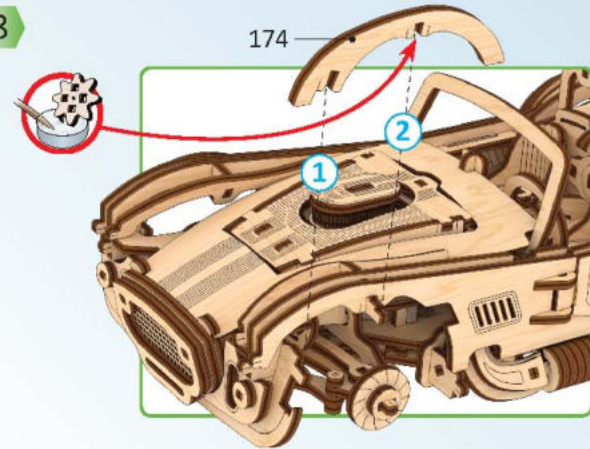



9

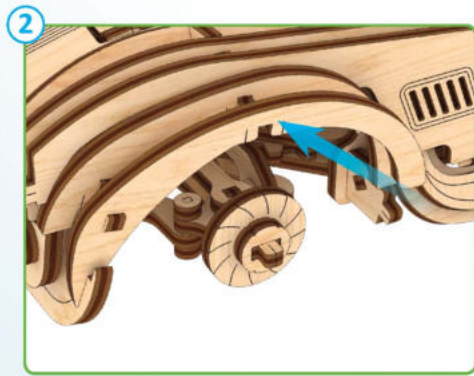
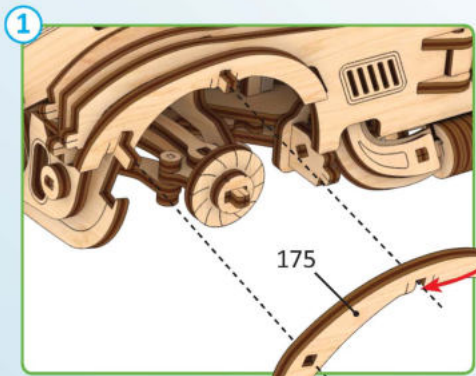

10

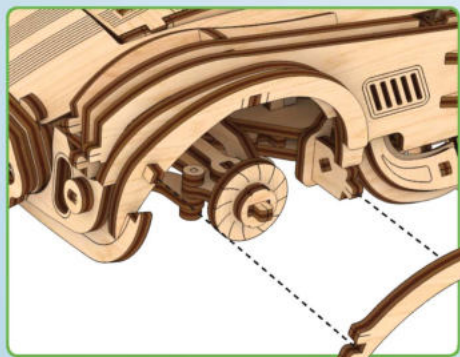

e1

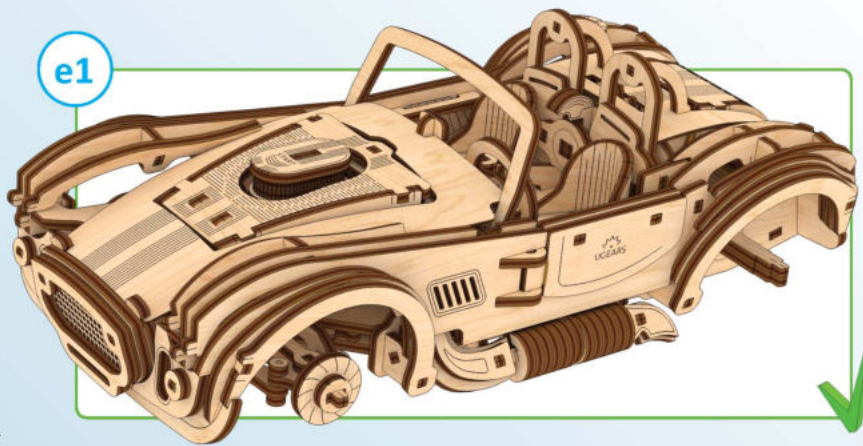

1

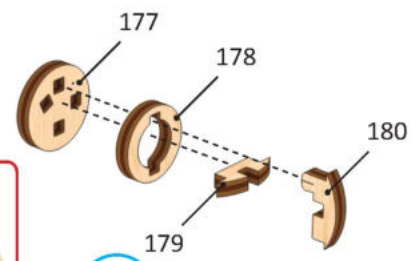
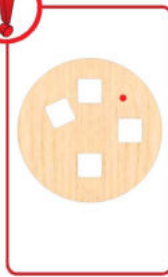

e2



2

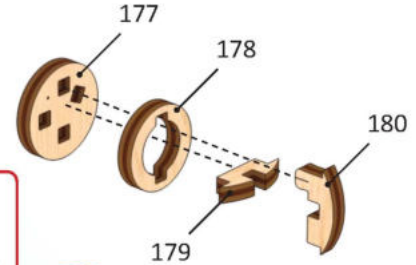
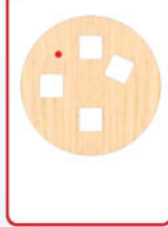

e3



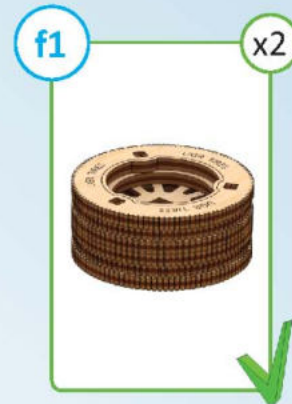
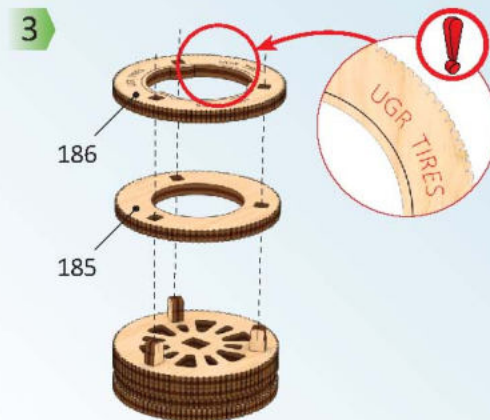
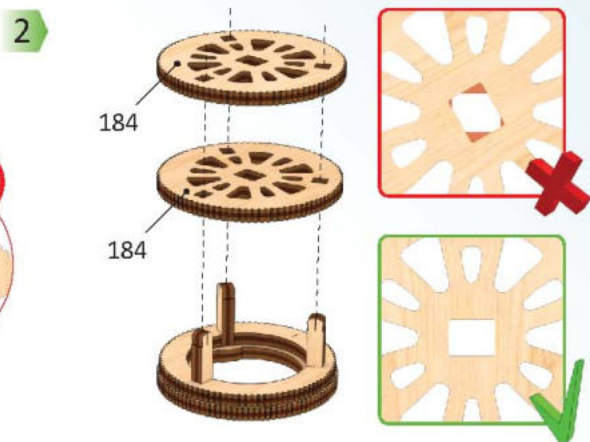
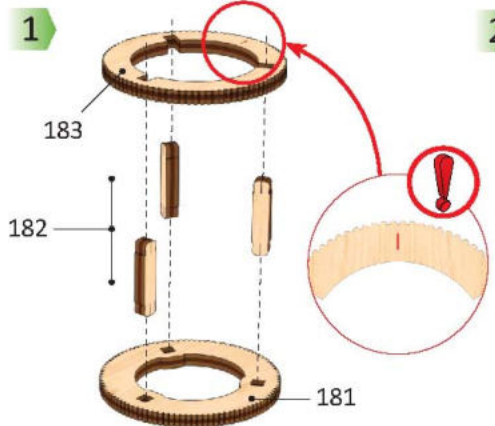
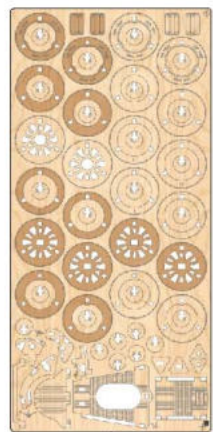
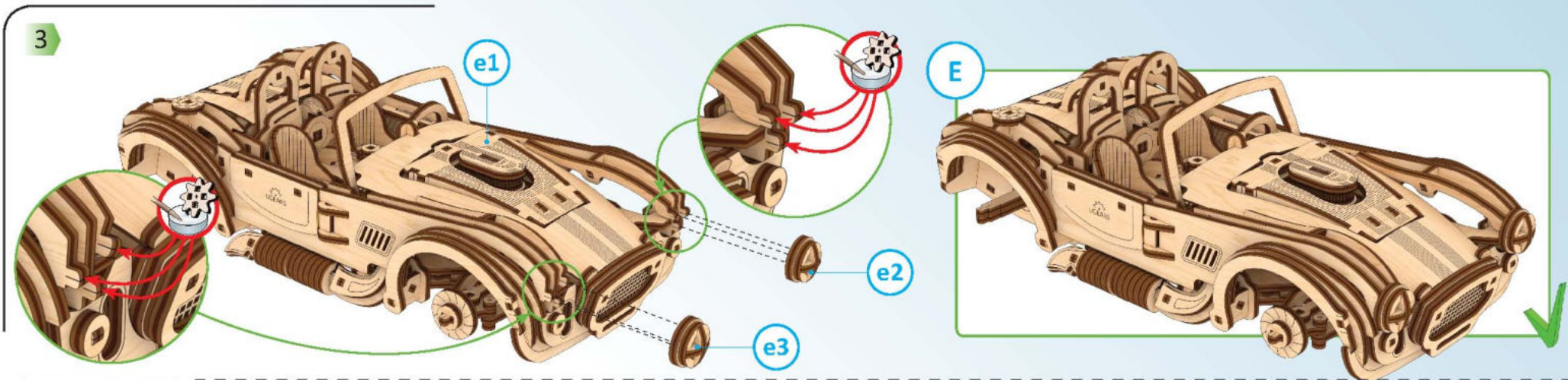

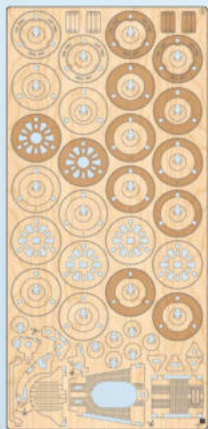

5

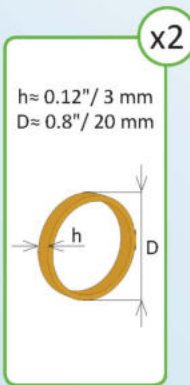

4



5



f2



x2

1

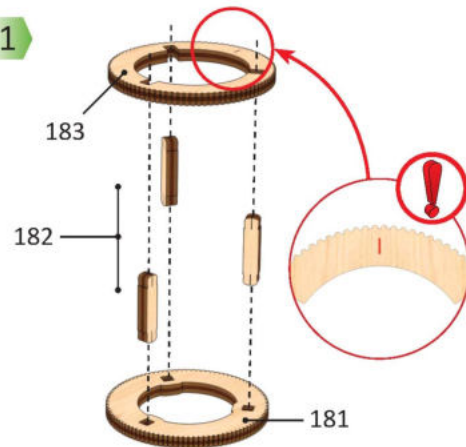

2

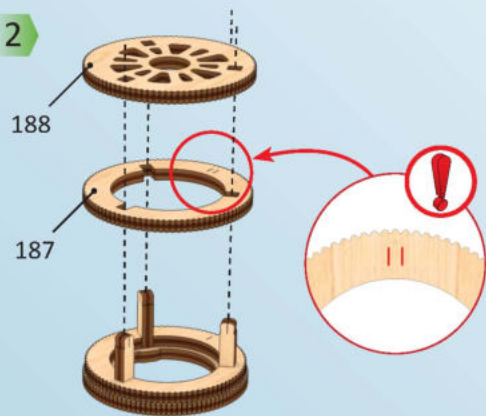

3

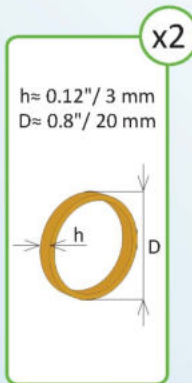
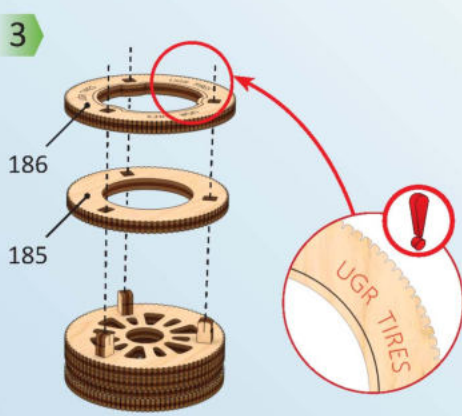

4

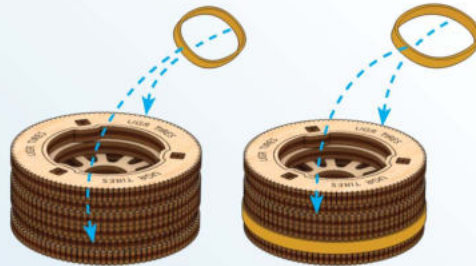

5

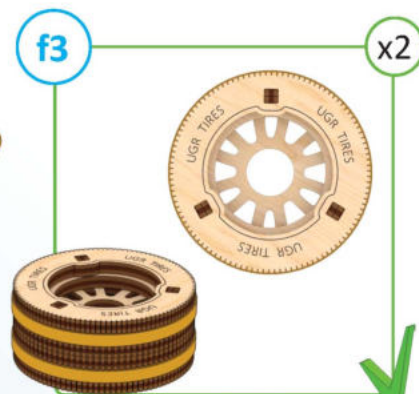

1

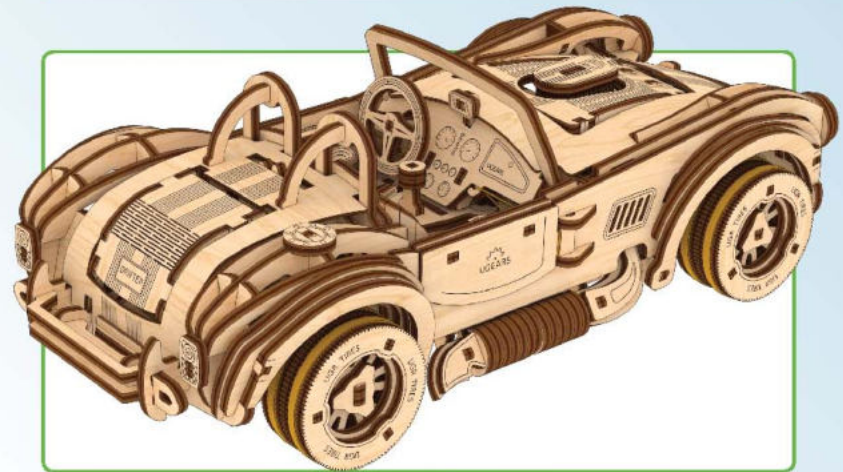
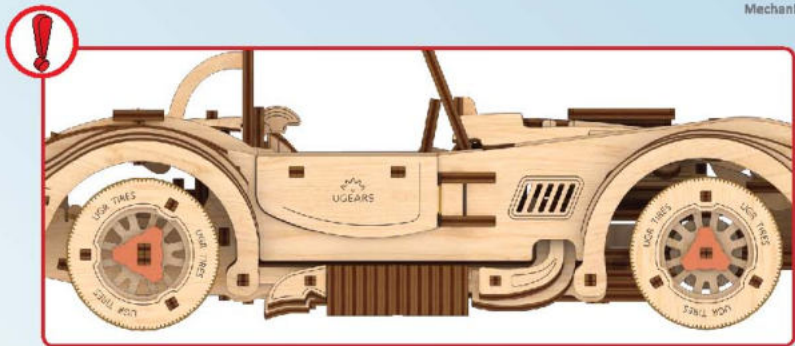
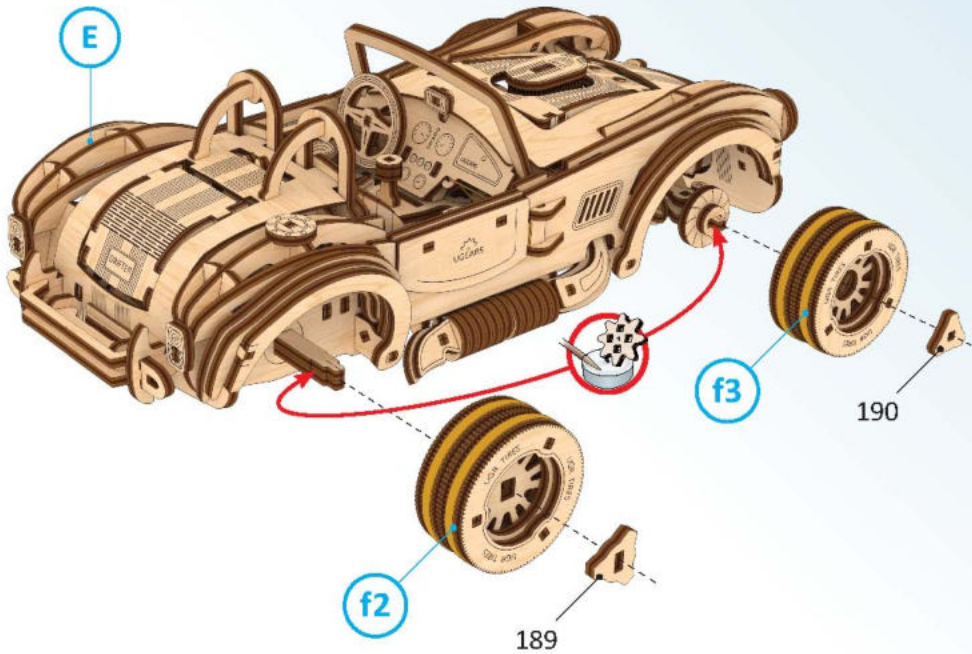
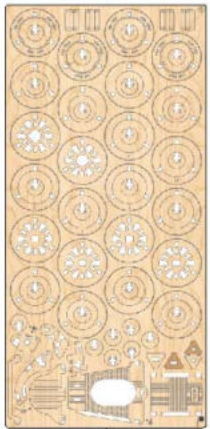

2

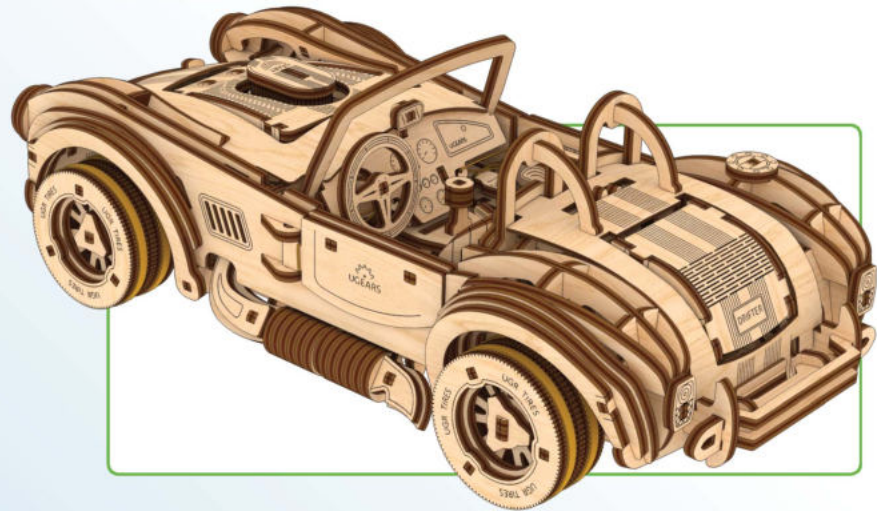
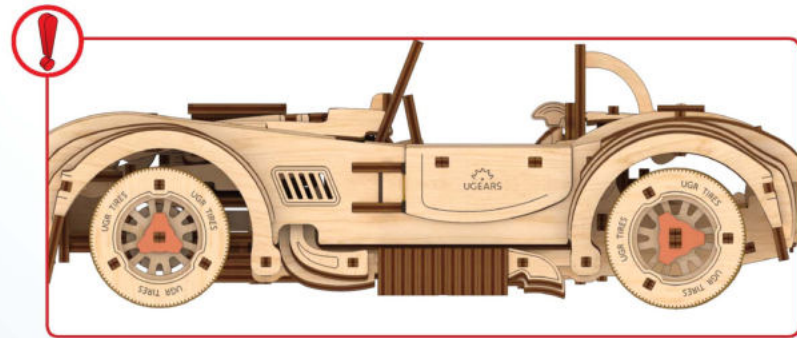
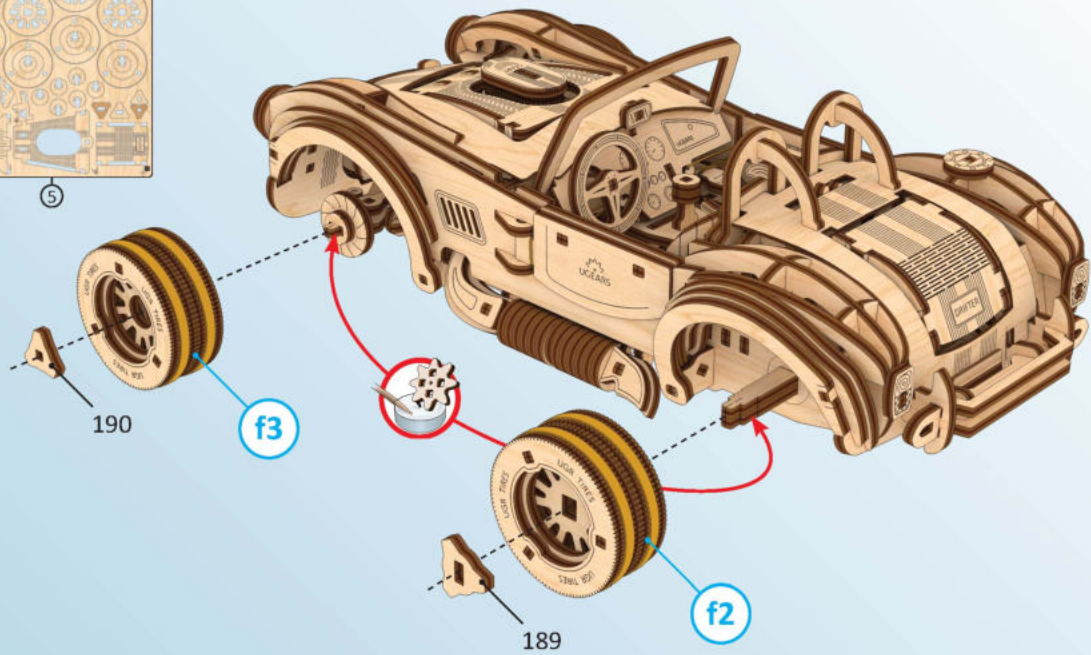
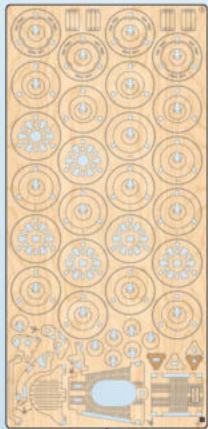

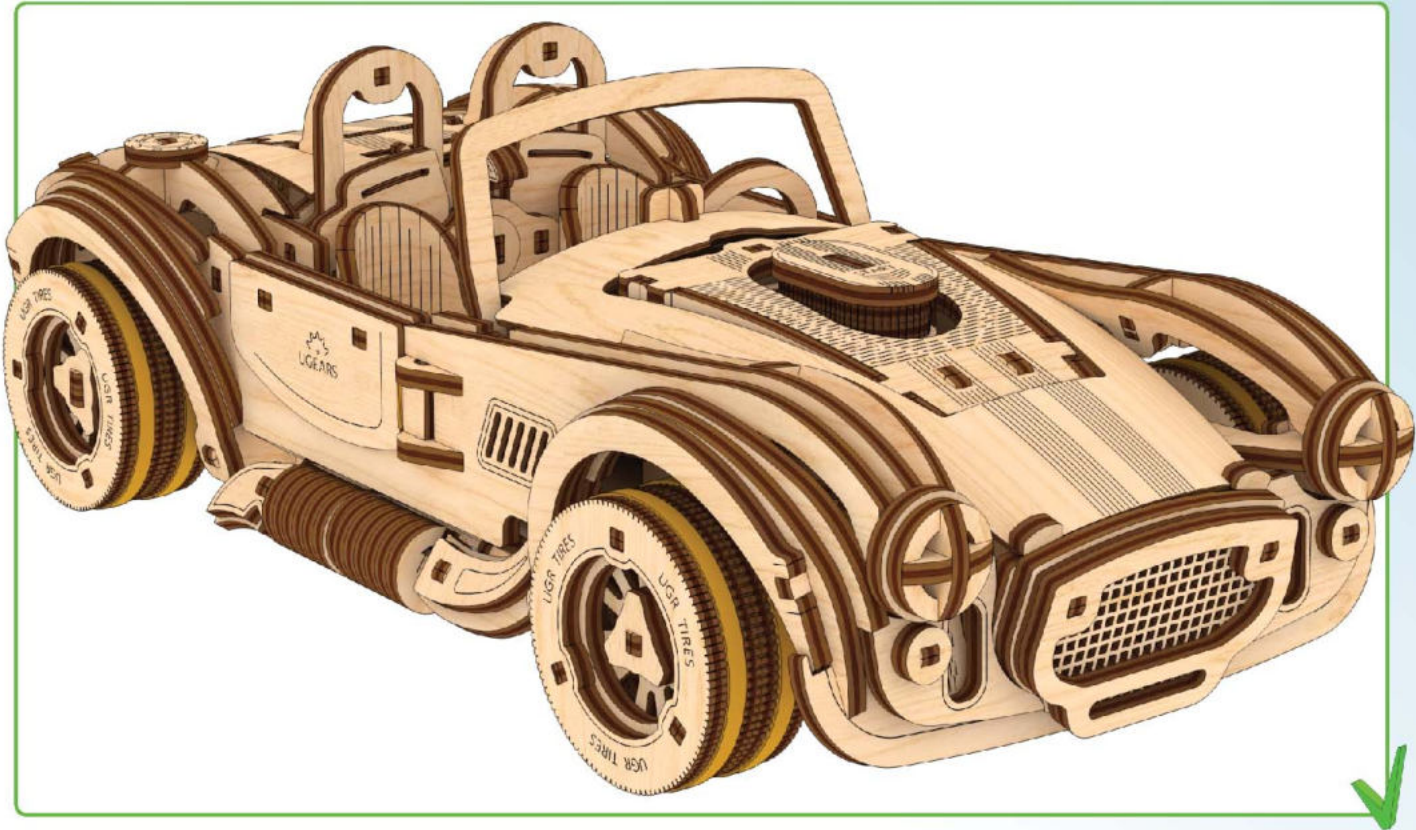

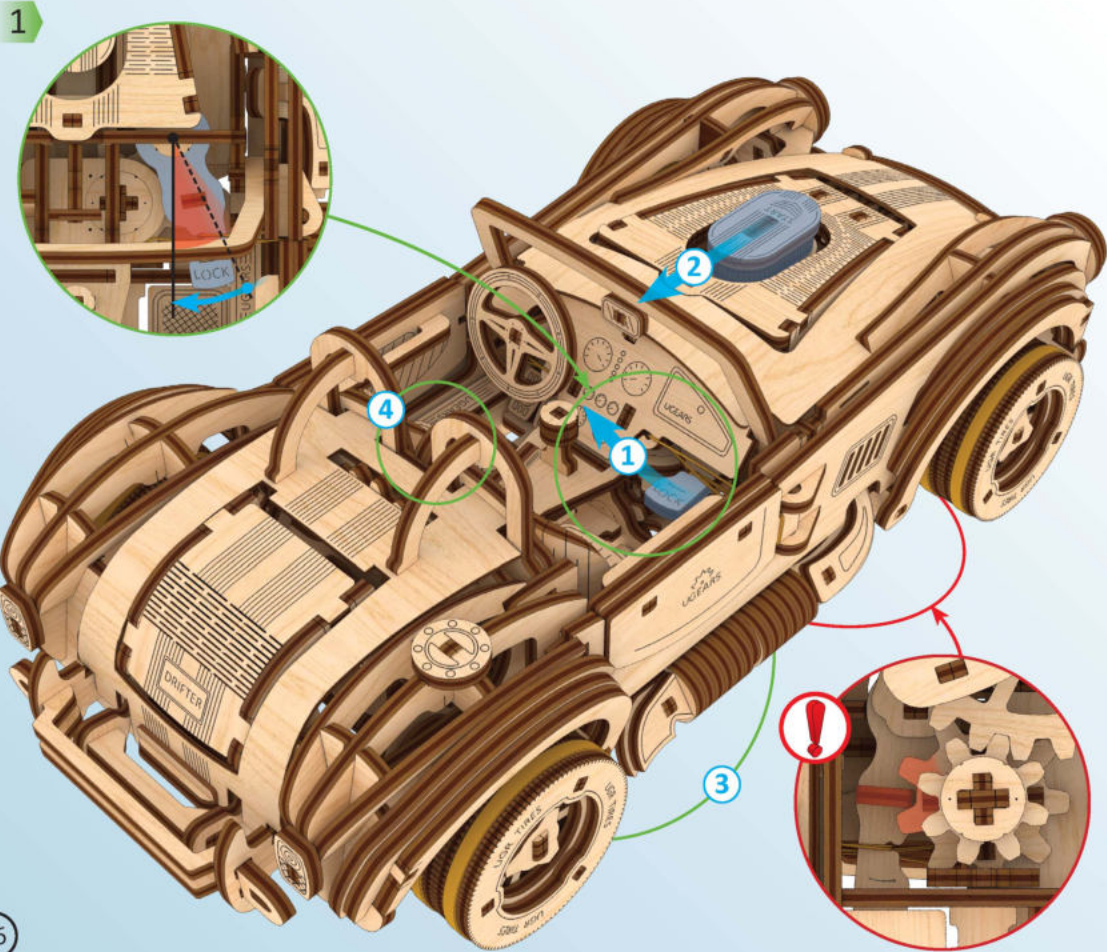

2

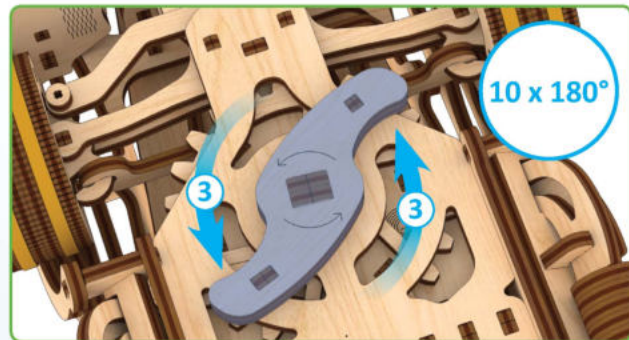

3

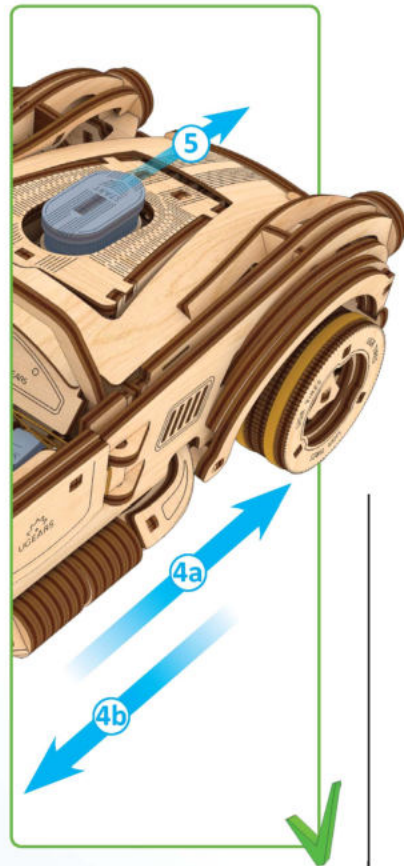
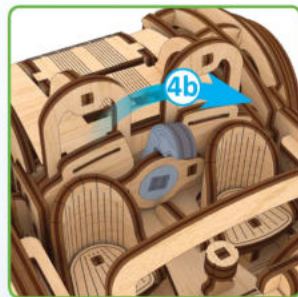
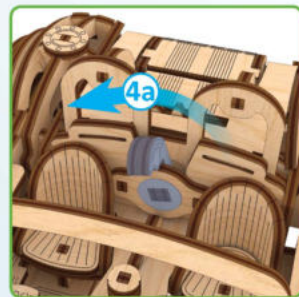

ENG The car can drive / drift in different ways depending on the type of surface (slippery or rough) and the presence / absence of rubber bands on the wheels. **UKR** Автомобіль може їздити/дріфтувати по-різному, залежно від типу поверхні (слизька або шершава) та наявності/відсутності гумок на колесах **FRA** La voiture peut rouler / drifter de différentes manières selon le type de surface (glissante ou rugueuse) et la présence / absence d'élastiques sur les roues. **DEU** Je nachdem, ob die Oberfläche rutschig oder rau ist und ob die Räder mit Gummiband versehen sind oder nicht, fährt / driften der Wagen unterschiedlich. **SPA** Según el tipo de superficie (resbaladiza o rugosa) y la presencia / ausencia de gomas elásticas en las ruedas, el coche se moverá / hará drifting de forma diferente. **ITA** L'auto può guidare/fare drifting in diversi modi a seconda del tipo di superficie (scivoloso o ruvido) e della presenza / assenza di elastici sulle ruote. **JPN** この車は表面の状態 (滑らか/粗い) あるいはホイールのゴムバンドの有/無により、他の方向にドライブドリフトが可能です。 **CHI** 根据表面类型 (光滑或粗糙) 以及车轮上是否有橡皮筋, 汽车可以以不同的方式行驶/漂移。 **RUS** Автомобиль может ездить/дрифтовать по-разному в зависимости от типа поверхности (скользящая или шероховатая) и наличия/отсутствия резинок на колесах **POL** Samochód może jeździć / driftować w różny sposób w zależności od rodzaju nawierzchni (śliska lub szorstka) i obecności / braku gumek na kołach.. **KOR** 자동차는 바닥면(미끄럽거나/거칠거나)에 따라, 바퀴의 고무밴드 장착 유무에 따라 다른 방향으로 드리프트 될 수 있습니다.

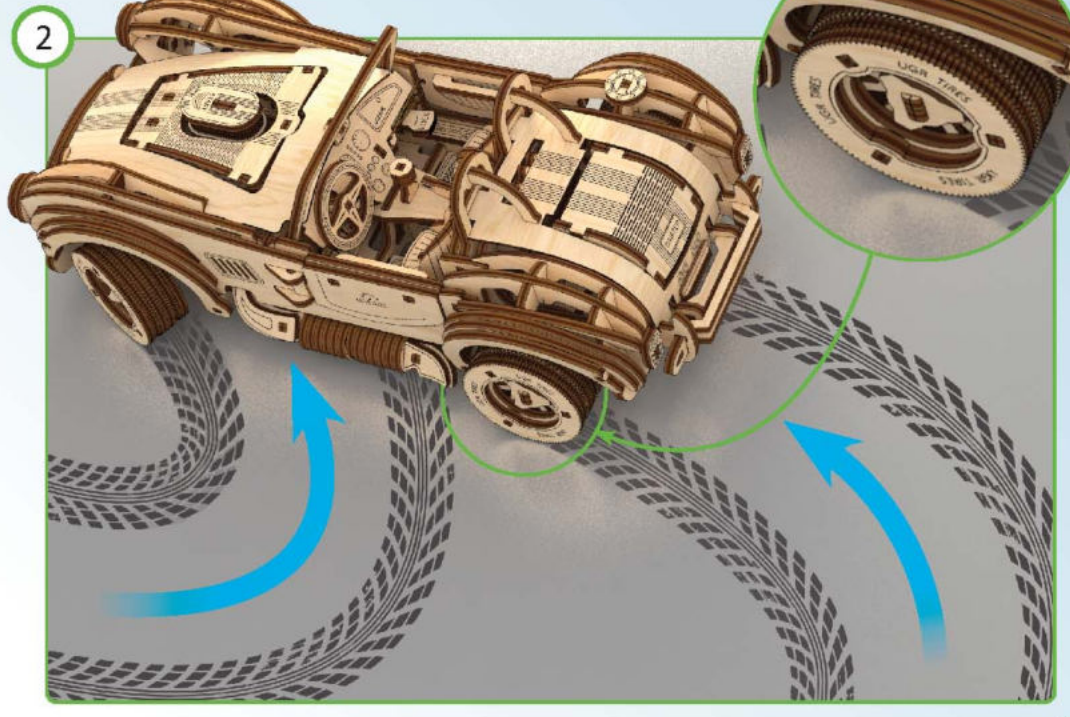
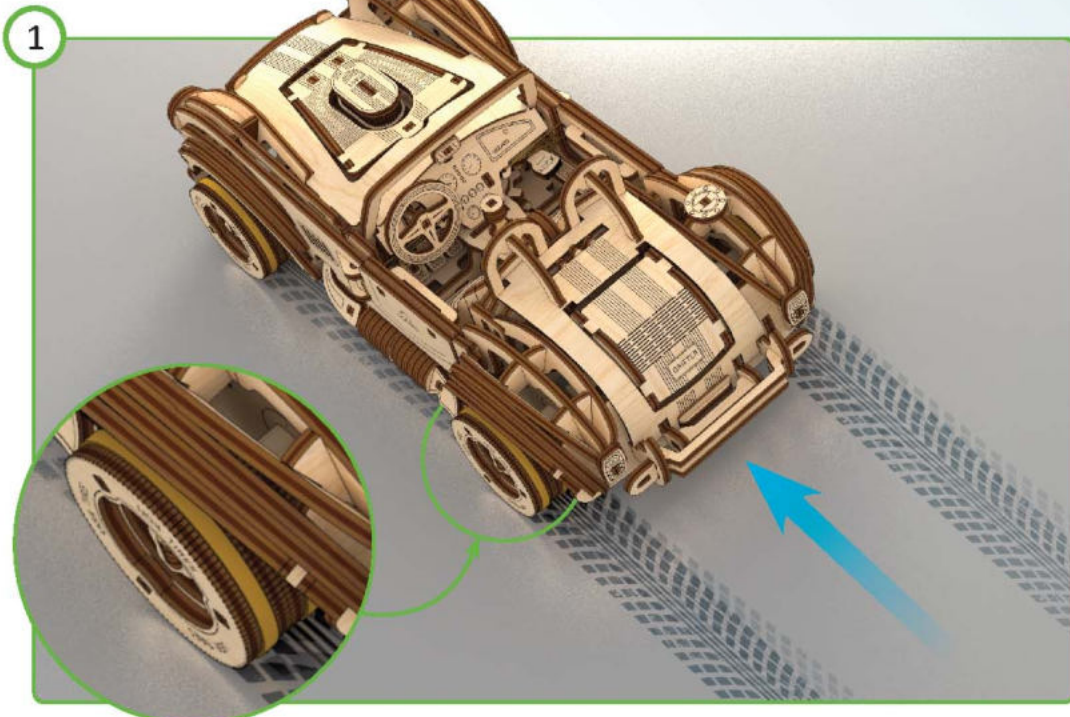

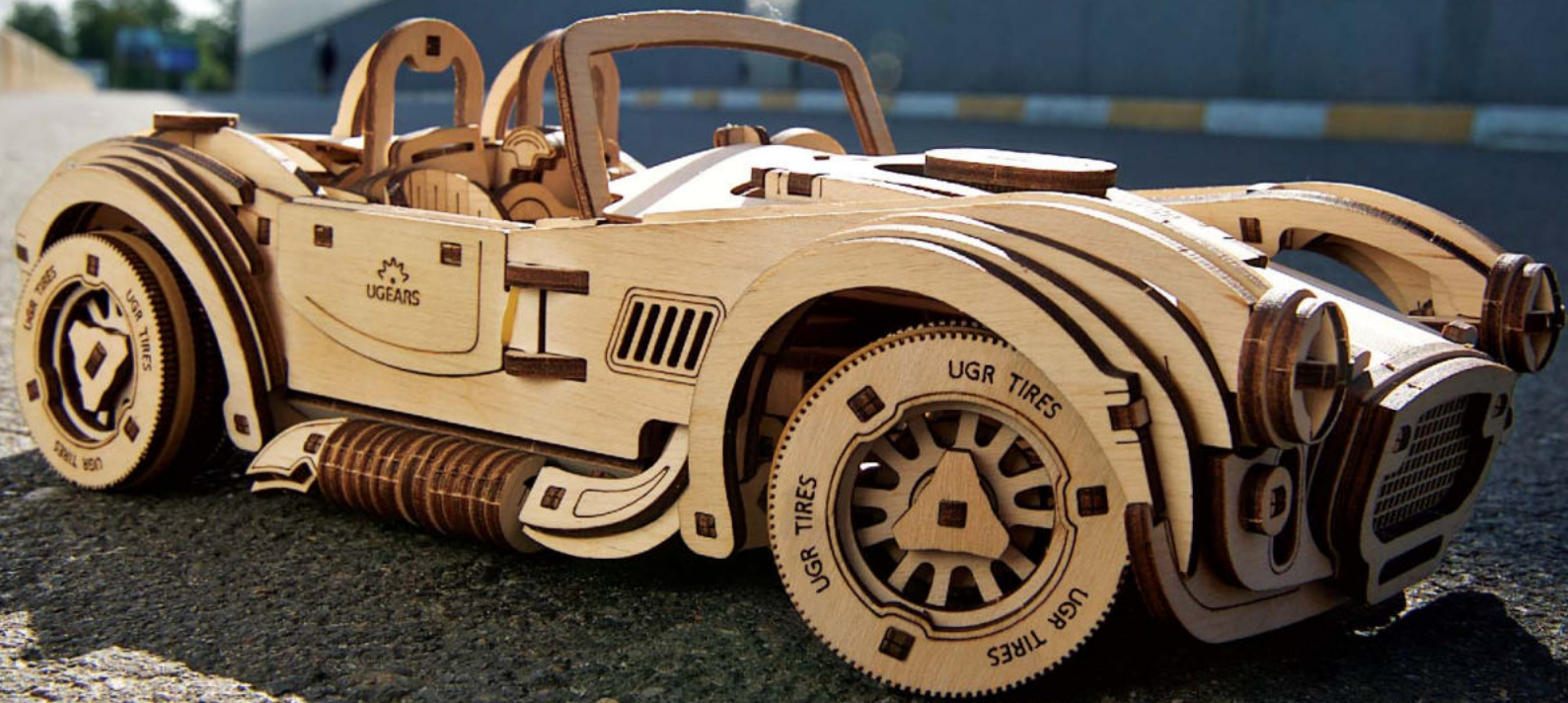



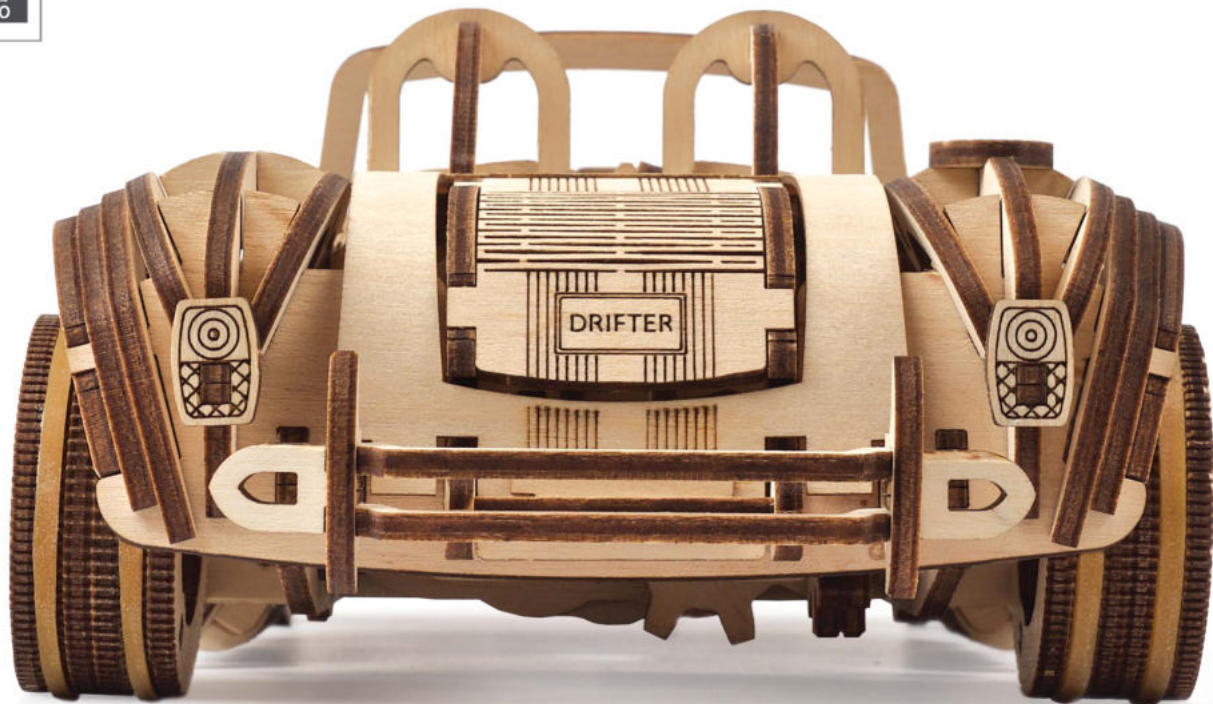

UGEARS®
Mechanical models

ENG Thanks for following along on this journey with us.

UKR Дякуємо, що ви пройшли цей шлях з нами.

FRA Merci denous avoir accompagnés tout au long de ces étapes.

DEU Vielen Dank, dass Sie diesen Weg mit uns gegangen sind.

SPA Gracias por haber recorrido el camino con nosotros.

ITA Grazie per aver fatto uesto percorso con noi.

JPN UGEARSをご利用いただきありがとうございます

CHI 感谢您参与有趣的模型配装过程。

RUS Спасибо, что вы прошли этот путь с нами.

POL Dziękujemy, że razem z nami pokonałeś tę drogę!

KOR UGEARS 와 함께해 주셔서 감사합니다.

ugearsmodels.com

ENG Customer support **UKR** Служба підтримки

FRA Service client **DEU** Kundendienst

SPA Servicio al cliente **ITA** Servizio di supporto

JPN お客様窓口 **CHI** 客户支持 **RUS** Служба поддержки

POL Wsparcie klienta **KOR** 고객지원

customerservice@ugearsmodels.com