

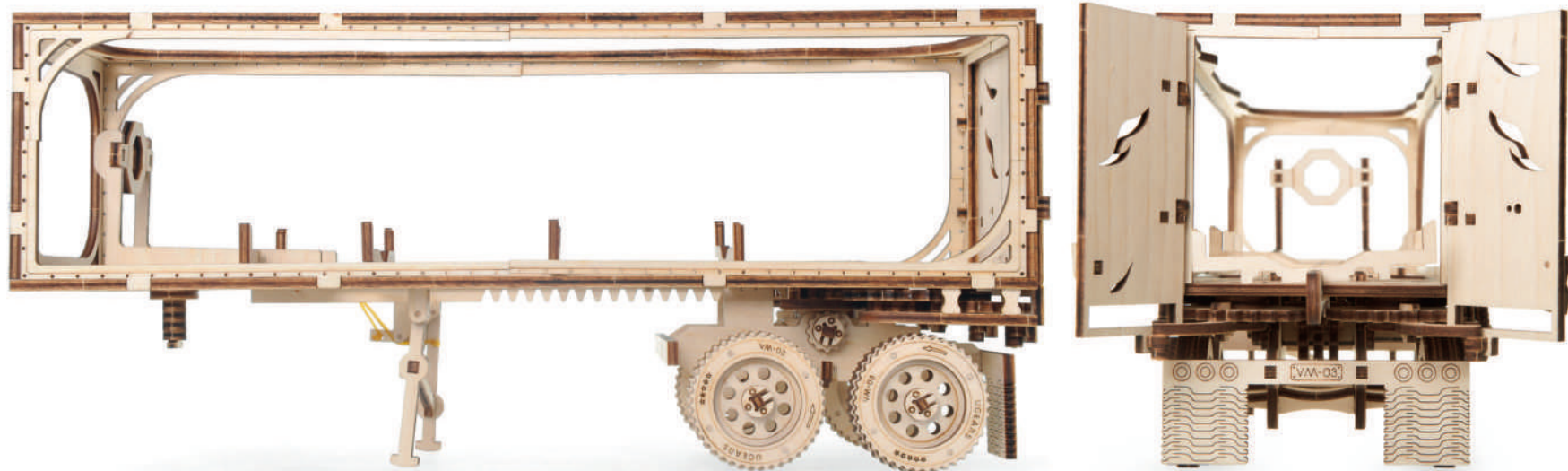

Find out MORE

Assemble Me. Hook Up & Load Me



Model
«Trailer for «Heavy Boy Truck VM-03»
Модель
«Напівпричіп до моделі «Тягач VM-03»

DEU Modell «Anhängen für Schwerer LKW VM-03»
FRA Modèle «Remorque Poids-Lourd VM-03»
POL Model «Przyczepa do Modeli «Ciężarówka VM-03»
SPA Modelo «Remolque Tráiler VM-03»
ITA Modello «Rimorchio per Autotreno VM-03»
TUR Model «Heavy Boy» Treyler VM-03, Dorsesi»
RUS Модель «Полуприцеп к модели «Тягач VM-03»
KOR 대형 트럭 VM-03 트레일러
CHI 重型卡车 VM-03 之挂车

Assembly instructions
Інструкція зі складання

DEU Aufbauanleitung, FRA Notice d'assemblage,
POL Instrukcja montażu, SPA Instrucciones de montaje,
ITA Istruzioni di montaggio, TUR Kurulum talimatı,
RUS Инструкция по сборке, KOR 조립 설명서,
CHI 装配说明书



NATURAL
Made from wood materials



NO GLUE CONNECTION
Assembling without glue and chemicals



SELF ASSEMBLY
Details are already cut and ready to assemble



MECHANICAL
The models produce motion



EDUCATIONAL
Perfect for family projects through hands-on STEM learning

ENG

Assembly instructions:
Remove model parts from the hanger board as illustrated below. Careful not to break parts. If a part does not remove easily, carefully cut it out with a knife. This model is intended for self-assembly without glue. If you have difficulty installing the axles, try waxing them with a regular candle. All moving parts can also be waxed during assembly to reduce friction when operating the model.

TUR

Kurulum talimatı:
Şemada işaretlenen parçaları tahtadan çıkarın. Kırılmamasına dikkat ediniz. Parça çıkarılmıyorsa bağlantı yerleri bıçakla kesiniz. Konstrüksiyon, yapıştırıcı kullanmadan yapılmaktadır. Tahta dingilini (kürdan) deliğin içine yerleştirmede zorluk çekiyorsanız önceden dingile veya parçalara mum sürünüz. Hareketli parçaların daha iyi kayması için kurulum sırasında parçalara mum sürünüz.

UKR

Інструкція зі складання:
Витягніть з дошки позначені на схемі деталі. Намагайтеся їх не зламати. Якщо деталь не виймається, надісіть перемички ножом. Конструкція збирається без клею. У разі виникнення труднощів з протягуванням зубочистки (вісі) в отвір, потріть зубочистку об звичайну свічку. Також можна змастити свічкою всі деталі механізму, щоб зменшити тертя при обертанні.

RUS

Инструкция по сборке:
Вынимайте из доски обозначенные на схеме детали. Старайтесь их не сломать. Если деталь не извлекается, надрежьте перемычки ножом. Конструкция собирается без клея. Если возникли трудности с установкой деревянной оси, перед установкой потрите детали об обычную свечу. Для лучшего скольжения смазывайте движущиеся детали механизма обычной свечой во время сборки.

DEU

Aufbauanleitung:
Bitte die in der Zeichnung angegebenen Teile aus der Platte herausnehmen. Versuchen Sie bitte diese nicht zu brechen. Wenn sich ein Teil nicht herausnehmen lässt, schneiden Sie die Stege mit dem Messer leicht an. Das Modell wird ohne Klebstoffe zusammengebaut. Lässt sich eine Achse nur schwer in eine Öffnung einführen, reiben Sie diese mit einer Kerze etwas ein. Für besseres Gleiten schmieren Sie alle beweglichen Teile mit einer Kerze.

KOR

조립 설명:
부품이 손상되지 않도록 주의하여 보드에서 떼어냅니다. 만약 부품이 잘 떨어지지 않으면 연결 부분을 칼로 절단 한 후 떼어 내면 쉽게 떼어 낼 수 있습니다. 본 제품은 접착제가 없이 조립이 가능하도록 설계되어 있습니다. 만약 축이 잘 끼워지지 않는 경우 양초를 축에 바른 후 끼워 보세요. 모든 구동 부위는 제품 구동 시 원활한 작동이 가능하도록 조립 과정에서 윤활제(양초)양초를 발라 주세요.

FRA

Notice d'assemblage:
Faites sortir de la planche les pièces comme indiquées sur le schéma. Tâchez de ne pas les casser. Si la pièce ne sort pas, incisez les collages/fixations avec un couteau. La construction est à assembler sans colle. Si il est difficile d'introduire l'axe en bois dans l'orifice, frottez au préalable l'axe ou les pièces contre une bougie. Pour améliorer le glissement, traitez les pièces de frottement mobiles du mécanisme avec une bougie au cours d'assemblage.

CHI

装配说明
将模型部件按插图示，从胶合板取下。小心不要损坏件。如果取下时候有难度，请用小刀小心的切割连接点。这个产品不需要胶水粘接。如果安装转轴的时候有难度，请用普通的蜡加以润滑。所有的转动部分也需要打蜡润滑。

POL

Instrukcja montażu:
Delikatnie wyciągaj z deseczki wskazane w schemacie detale, starając się nie poćmacić elementów. Jeśli detal nie poddaje się, podetnij wiązadła nożem. Konstrukcje składa się bez kleju. Jeśli napotkasz trudności z instalacją drewnianej osi w otwór, potrzyj na początku oś lub detale o woskową świecę. Dla lepszego poślizgu polecano smarowanie ruchomych części mechanizmu zwykłą świecą podczas montażu.

SPA

Instrucciones de montaje:
Saque de la tabla las piezas marcadas en el esquema. Trate de no romperlas. Si una pieza no se saca, haga una incisión. La construcción va sin pegamento. Si tiene dificultades con la instalación del eje de madera en un agujero, frote primero el eje o las piezas contra una vela. Para un mejor deslizamiento, lubrique durante el montaje las piezas móviles del mecanismo con una vela común.

ITA

Istruzioni di montaggio:
Estrarre dal telaio i particolari indicati nello schema. Fare attenzione a non romperli. Se un particolare non si stacca, tagliare delicatamente gli elementi di collegamento con un coltello. L'assieme viene realizzato senza colla. In caso di difficoltà nell'inserimento di un perno in legno, è necessario sfregare il perno o il particolare con un po' di cera. Per uno scorrimento migliore incerare le parti mobili del meccanismo durante l'assemblaggio.

ENG Warning! **UKR** Увага! **DEU** Achtung! **FRA** Attention! **POL** Uwaga! **SPA** Precaución!
ITA Attenzione! **TUR** Dikkat! **RUS** Внимание! **KOR** 주의! **CHI** 注意!



ENG Do not use a lighted candle! **UKR** Не підпалювати! **DEU** Nicht anzünden! **FRA** Ne pas brûler! **POL** Nie podpalać! **SPA** ¡No encender!
ITA Non dare fuoco! **TUR** Yakmayın! **RUS** Не поджигать! **KOR** 불이 붙은 초를 이용하지 마세요! **CHI** 请勿点燃，请勿靠近火源!



ENG Caution! Axles have sharp points! **UKR** Обережно! Гострі деталі!
DEU Vorsicht! Spitze Teile! **FRA** Attention: certaines pièces sont pointues! **POL** Ostrożnie! Ostre części! **SPA** ¡Atención! Piezas afiladas!
ITA Attenzione! Particolari appuntiti! **TUR** Dikkat! Keskin parçalar!
RUS Осторожно! Острые детали! **KOR** 축의 뾰족한 부분에 주의하세요!
CHI 注意! 含尖锐部件

ENG Symbols. UKR Умовні позначення. DEU Legende. FRA Légende. POL Oznaczenia umowne.
 SPA Leyenda. ITA Legenda. TUR Kararlaştırılan işaretler. RUS Условные обозначения. KOR 기호. CHI 图标含义



ENG Wax the part with a regular candle (rub with a candle). UKR Змастіть деталь звичайною свічкою (потріть об свічку). DEU Reiben Sie das Teil mit einer einfachen Kerze etwas ein. FRA Lubrifiez la pièce avec une bougie ordinaire (frottez contre la bougie). POL Przesmaruj zwykłą świecę. SPA Engrase la pieza con una vela común (frote con una vela). ITA Incerare il componente (Sfregare con la cera). TUR Parçaya sade mum sürünüz. RUS Смажьте деталь обычной свечкой (потрите о свечку). KOR 표시된 부분에 윤활을 위해 초를 칠해 주세요. CHI 用普通蜡烛涂抹润滑部件。



ENG Pay attention. Check for correct orientation or positioning. UKR Зверніть увагу. Перевірте розташування елемента. DEU Bitte Beachten. Prüfen Sie die Einbaulage des Elementes. FRA Faites attention. Vérifiez la disposition de l'élément. POL Zwróć uwagę. Sprawdź lokalizację elementu. SPA Atención. Compruebe la situación del elemento. ITA Prestare attenzione. Controllare la posizione del componente. TUR Dikkat. Elemanın yerleşimini kontrol ediniz. RUS Обратите внимание. Проверьте расположение элемента. KOR 방향 또는 위치에 주의해서 조립해 주세요. CHI 注意！检查部件方向和位置



ENG The part should be easily rotated (moved). UKR Деталь повинна легко крутитися (рухатися). DEU Der Teil soll leicht gedreht (bewegt) werden. FRA La pièce doit tourner (se déplacer) aisément. POL Element powinien łatwo się kręcić (poruszać się). SPA La pieza debe ser fácil de girar (mover). ITA Il componente deve girare (muoversi) facilmente. TUR Parça kolayca dönmeli (hareket etmeli). RUS Деталь должна легко крутиться (двигаться). KOR 활하게 움직일 수 있어야합니다. CHI 此部件必须容易的旋转 (移动)



ENG SCut crosspieces before removing the part from the board. UKR Обріжте перемички перед витяганням деталі. DEU Schneiden Sie die Stege ein, bevor Sie das Teil rausnehmen. FRA Découpez les fixations avant de retirer les pièces. POL Obetnij uszczelnienia przed wyjmowaniem elementu. SPA Corte los puentes antes de extraer la pieza. ITA Tagliare gli elementi di collegamento prima di estrarre i particolari. TUR Parçaları çıkarmadan önce bağlantı yerlerini kesiniz. RUS Обрежьте перемычки перед выниманием детали. KOR 부품을 떼어내기 전, 연결 부분을 잘라 주세요. CHI 在取下部件前切断连接点



ENG Sand to remove burrs. UKR Видалить задирки. DEU Grate entfernen. FRA Éliminez les bavures. POL Usuń zadziory. SPA Quite las rebabas. ITA Togliere le bave. TUR Çapakları çıkartınız. RUS Удалите заусенцы. KOR 거친 부분을 다듬어 주세요. CHI 磨掉毛刺



ENG Break off or cut out. UKR Відламайте або відріжте. DEU Abbrechen oder Abschneiden. FRA Coupez ou cassez. POL Odłam lub odetnij. SPA Rompa o corte. ITA Staccare o tagliare. TUR Kırın veya kesin. RUS Отломайте или отрежьте. KOR 잘라내 주세요. CHI 切断

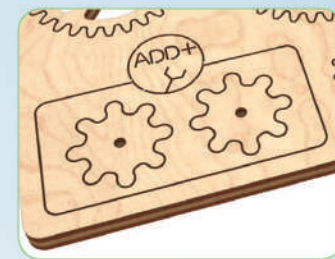

ENG Spare parts. UKR Запасні деталі. DEU Ersatzteile. FRA Pièces de rechange. POL Części zamienne. SPA Piezas de repuesto. ITA Pezzi di ricambio. TUR Yedek parçalar. RUS Запасные детали. KOR 여유 부품입니다. CHI 备用件

ENG Axle. UKR Біль. DEU Achse. FRA Axe. POL Oś. SPA Eje. ITA Perno. TUR Dingil. RUS Ось. KOR 축. CHI 轴承

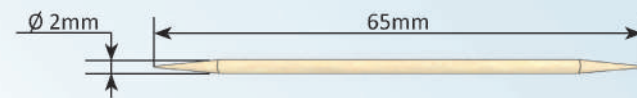

1:1

ENG Check size. UKR Перевірте розмір. DEU Prüfen Sie die Größe. FRA Vérifiez la dimension. POL Sprawdź rozmiar. SPA Compruebe el tamaño. ITA Controllare le dimensioni. TUR Boyutu kontrol ediniz. RUS Проверьте размер. KOR 크기를 확인해 주세요. CHI 測量尺寸

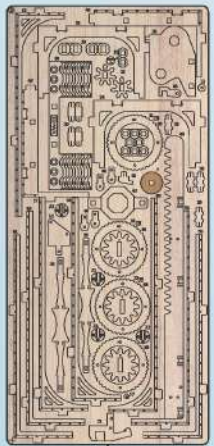
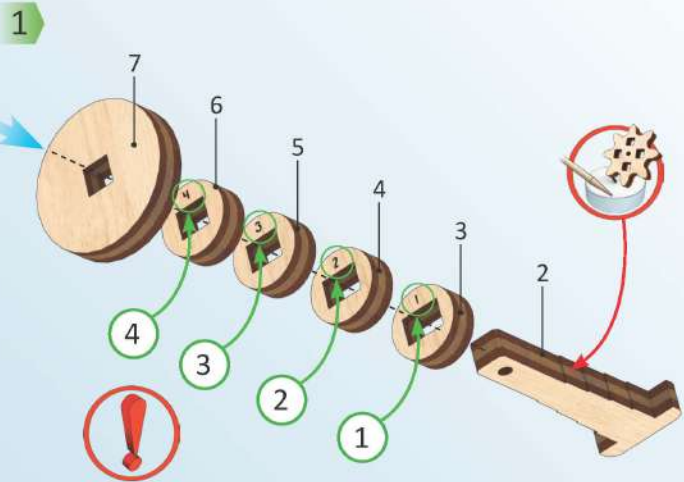
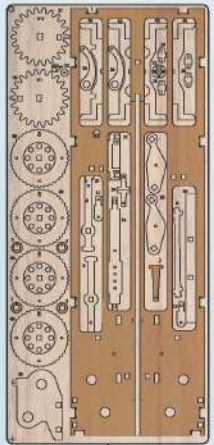

4

3

1

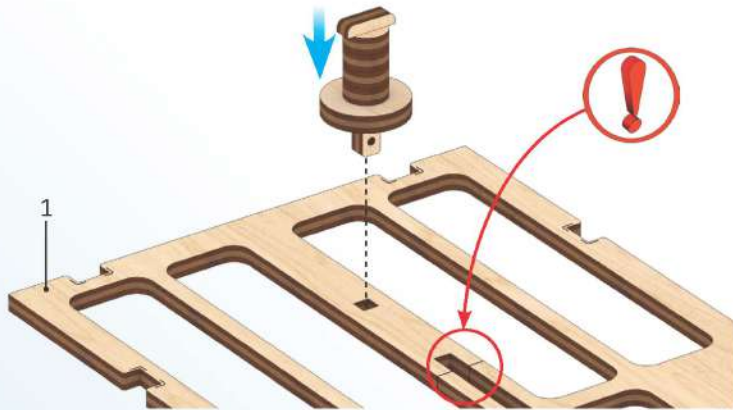

2

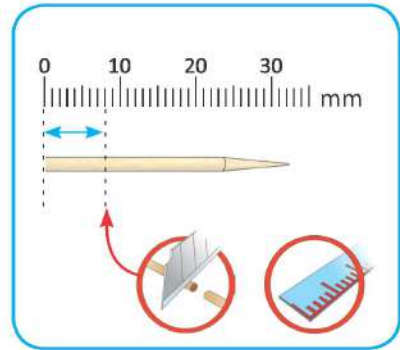

3

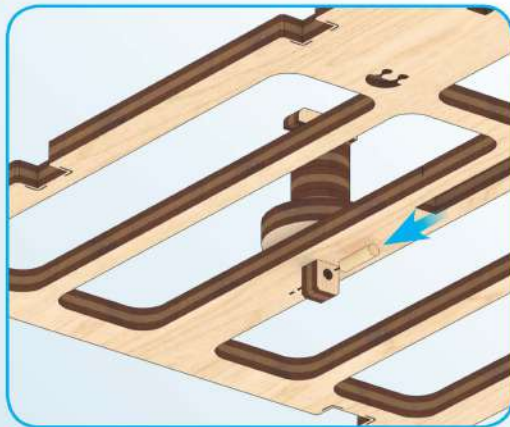

4

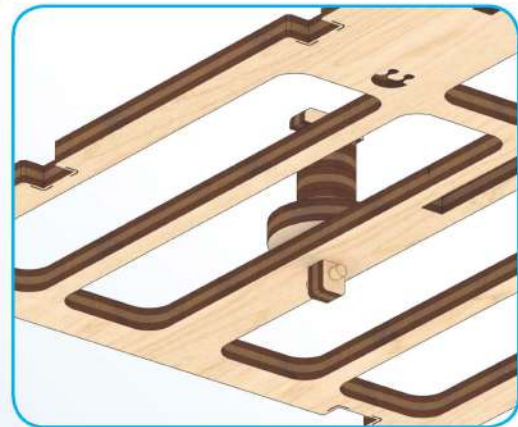

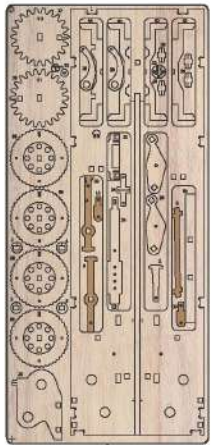

1

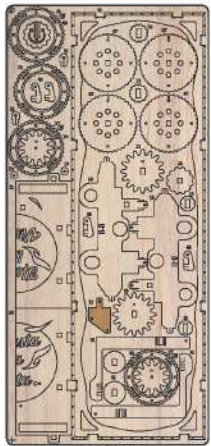

2

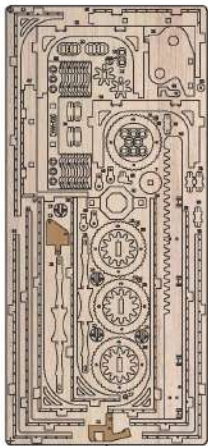

3

1

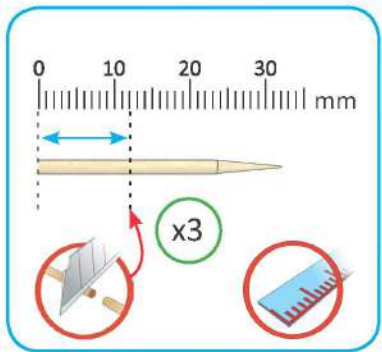

2

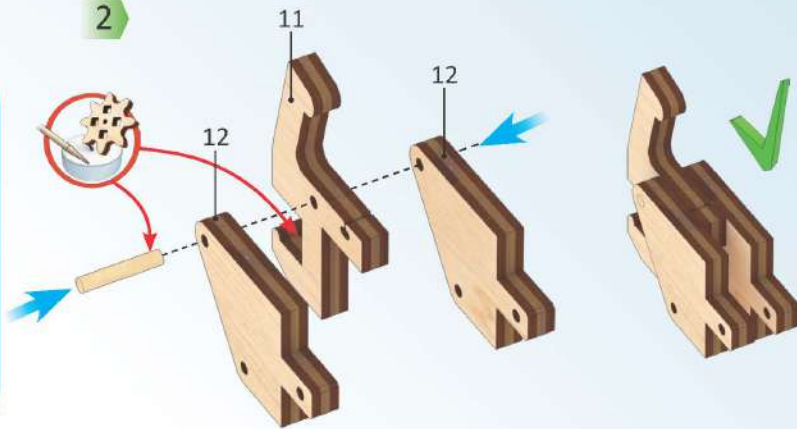

1

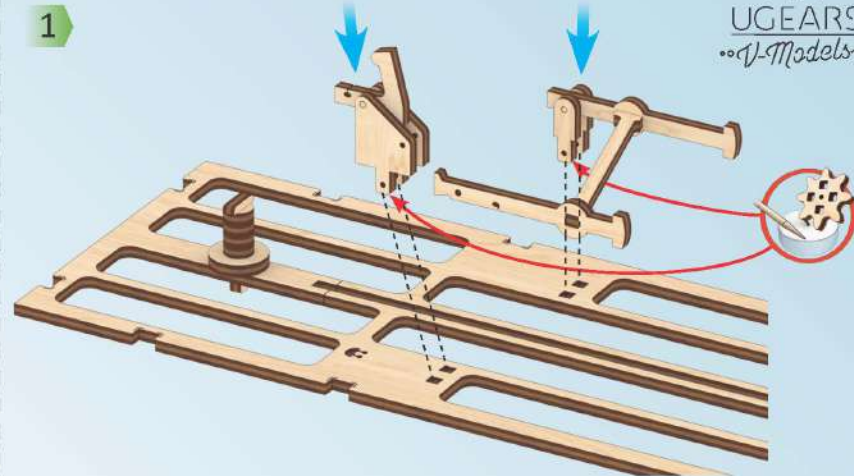

1

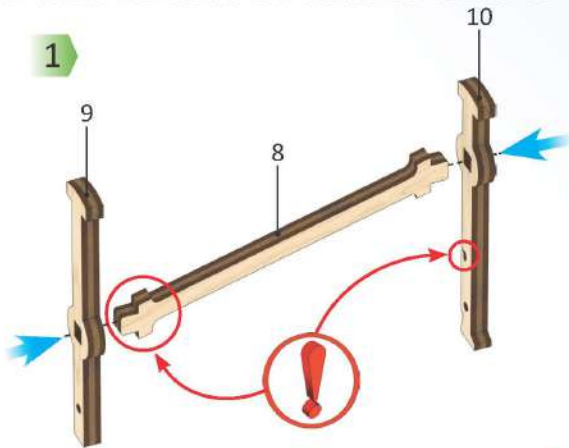

2

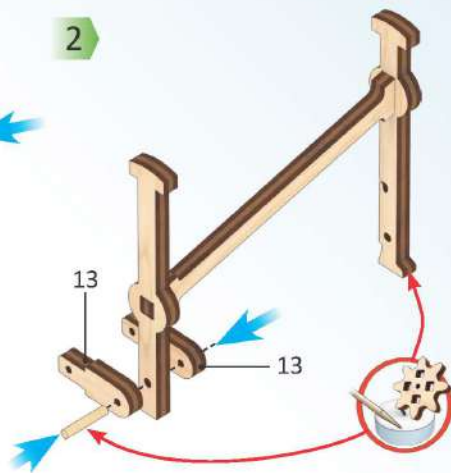

2

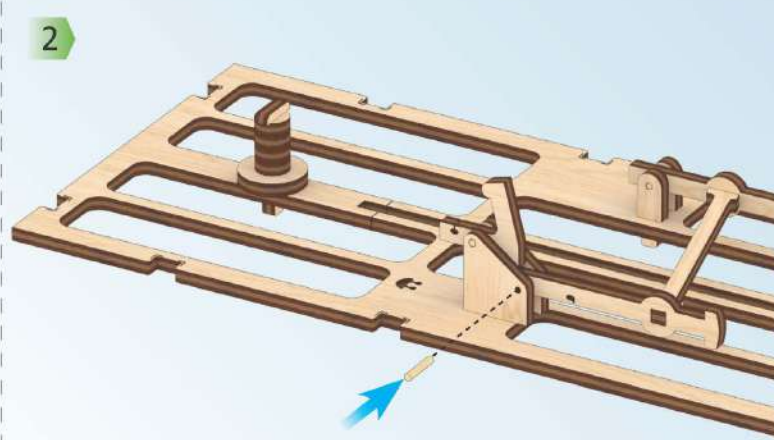

5

1

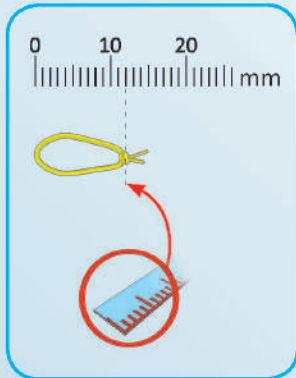

2

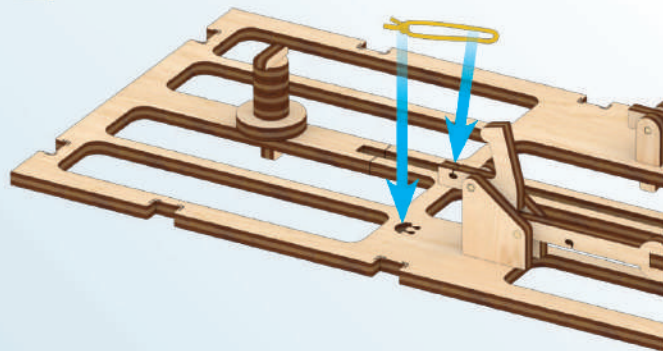

3

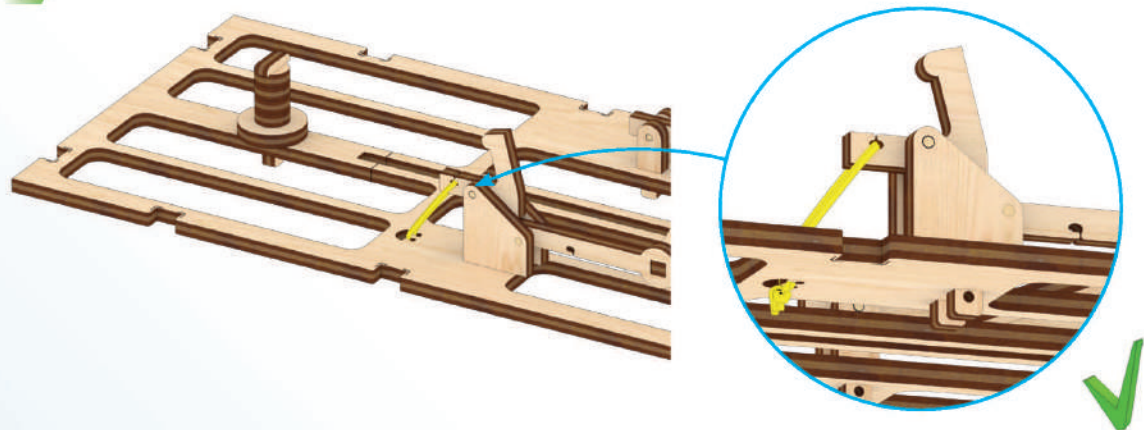

4

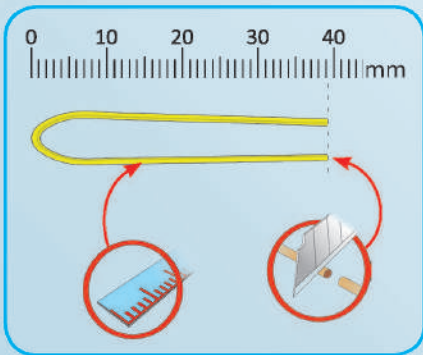

5

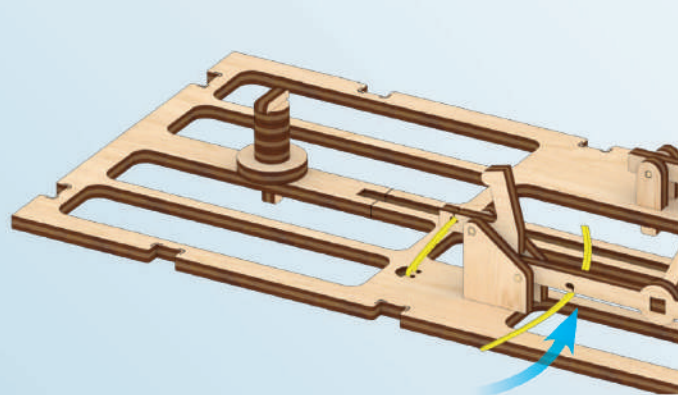

6

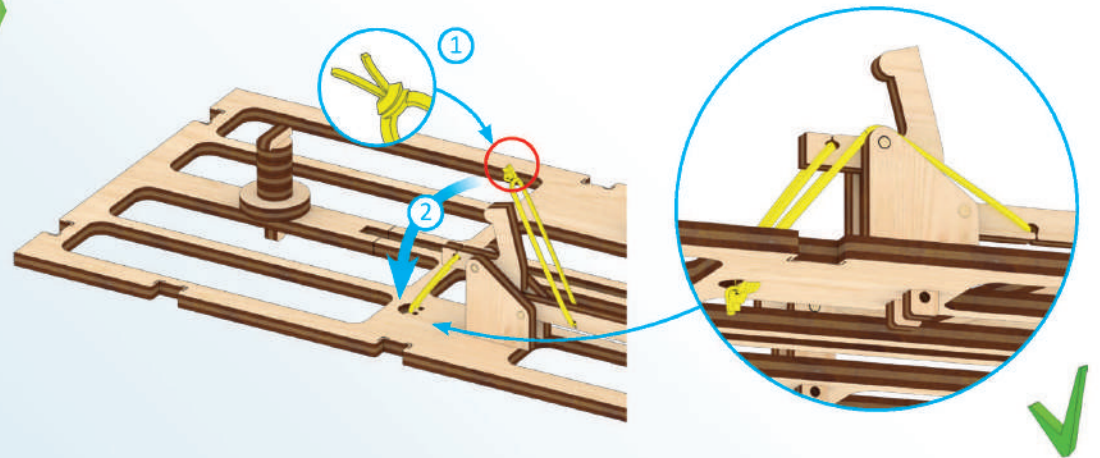

6

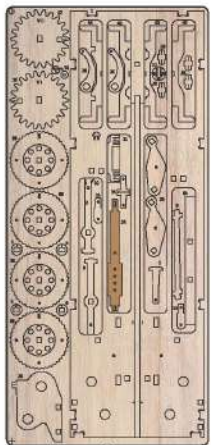

1

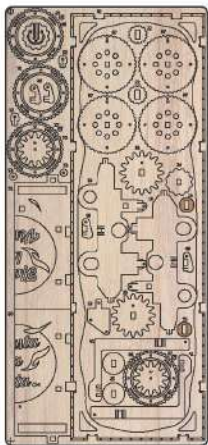

2

1

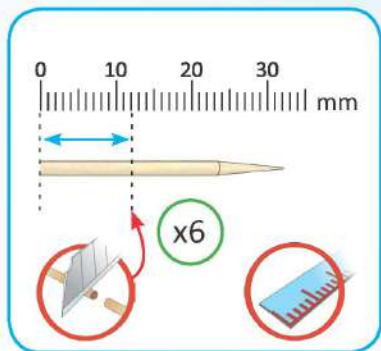

2

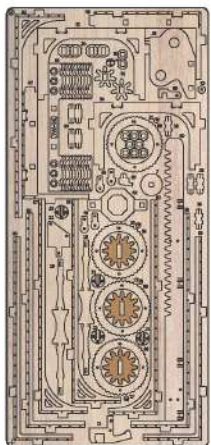
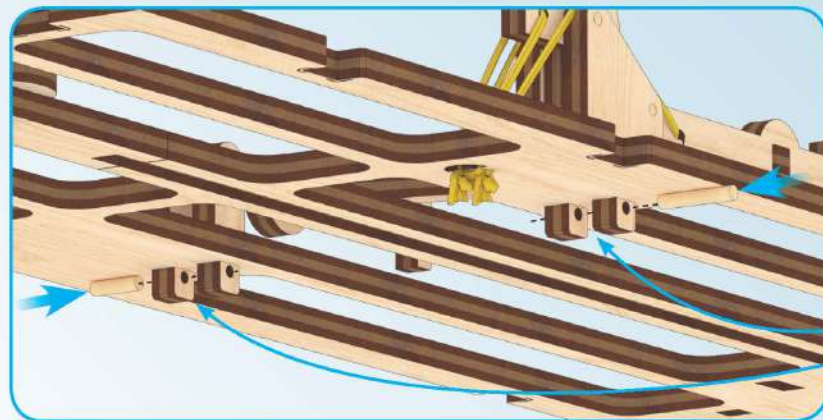

3

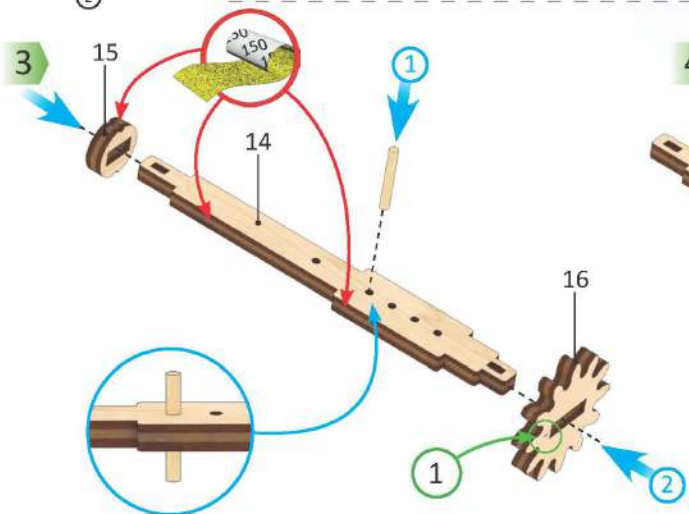

4

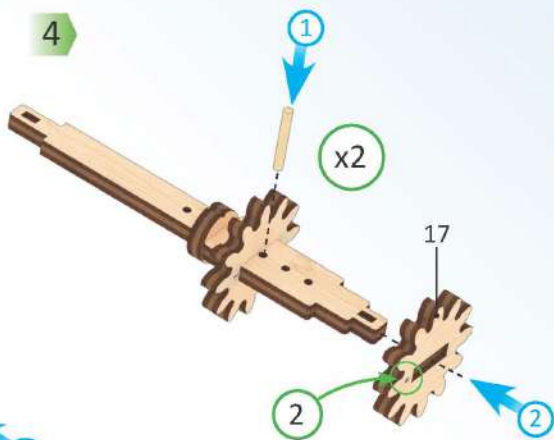

5

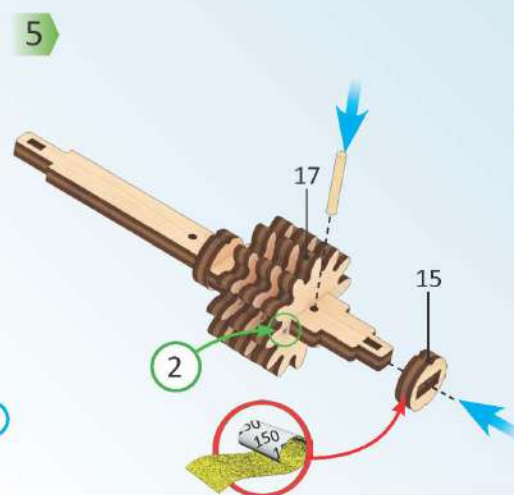

6



7

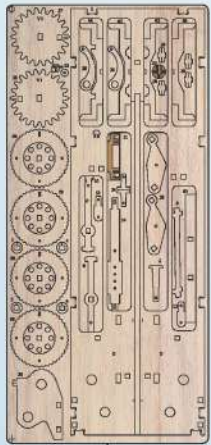

1

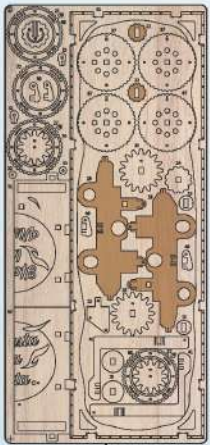

2

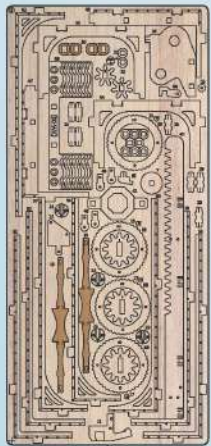

3

8

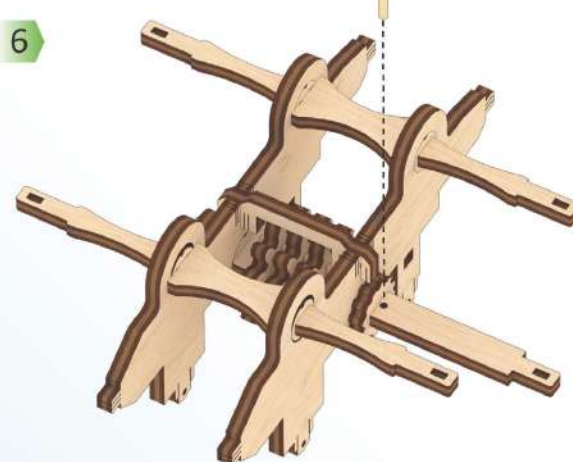
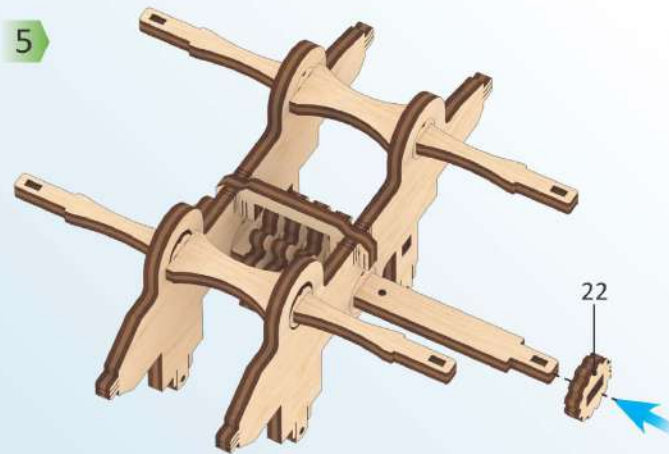
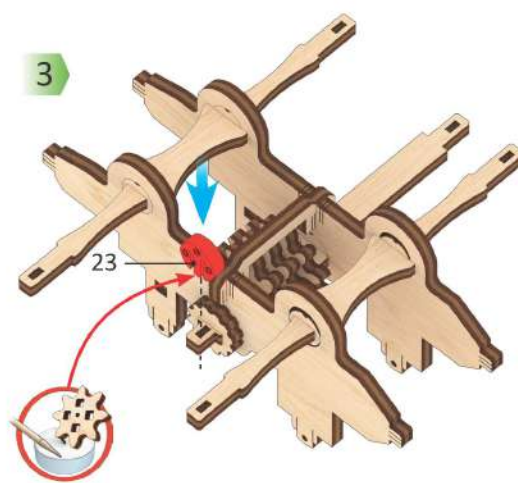
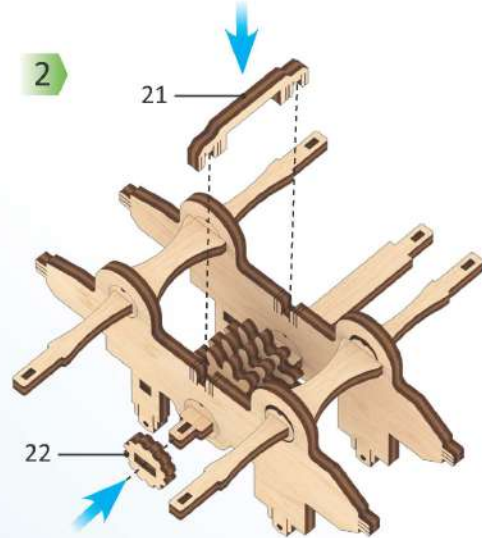
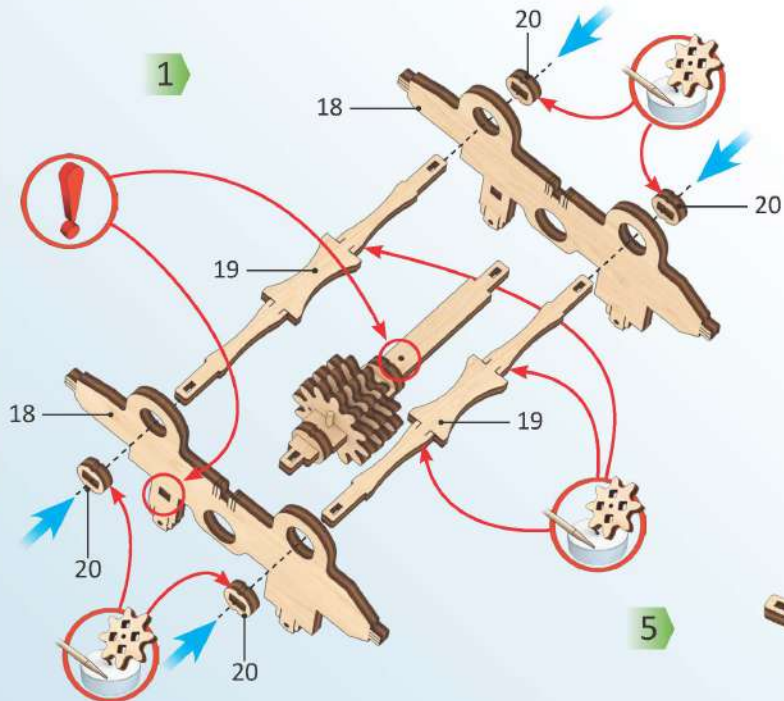

4

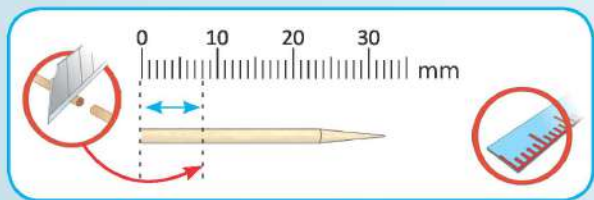

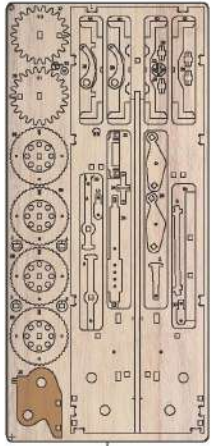

1

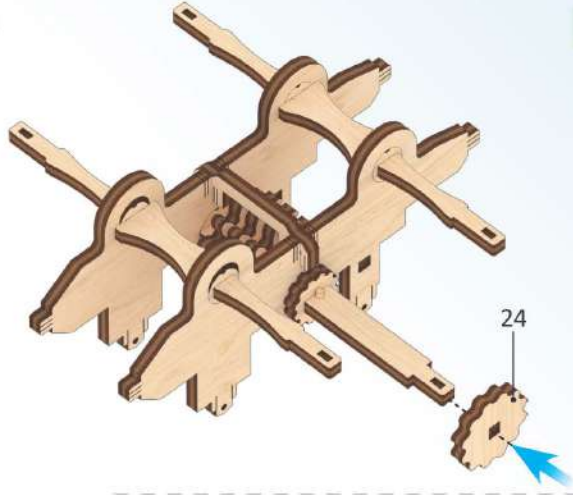

2

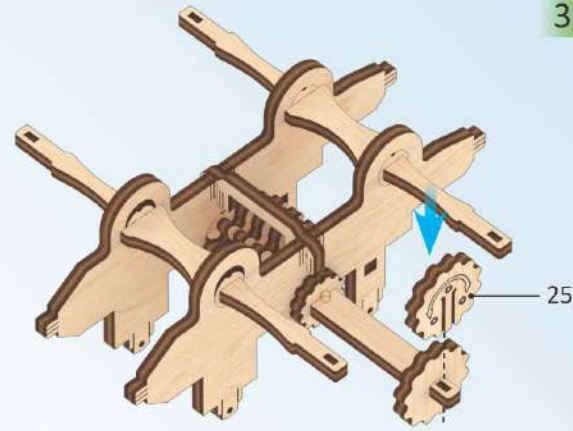

3

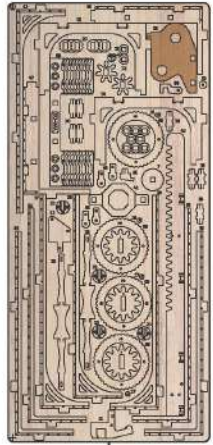
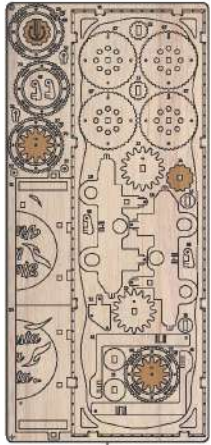

4

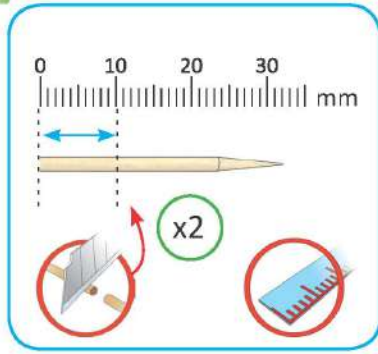

5

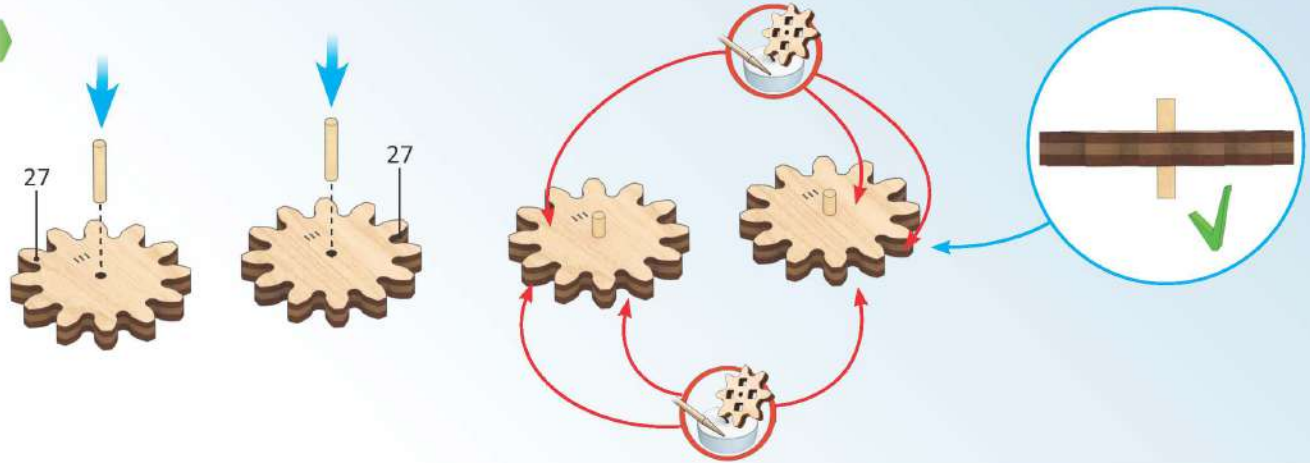

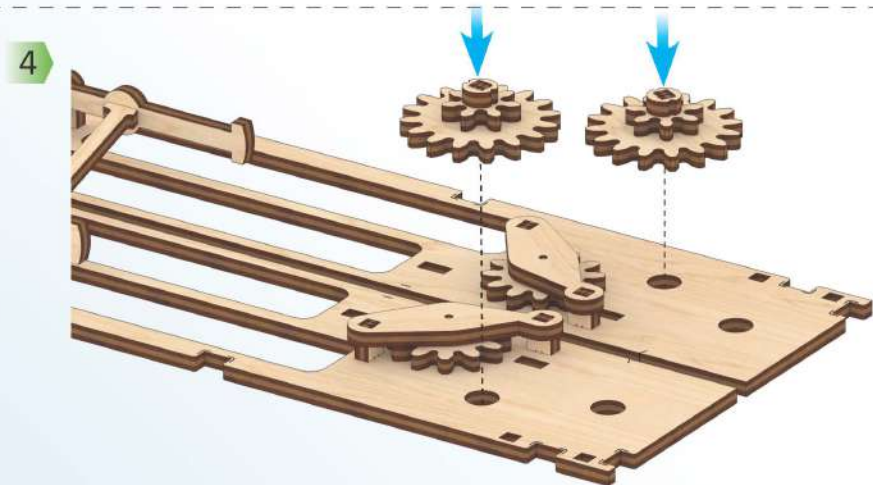
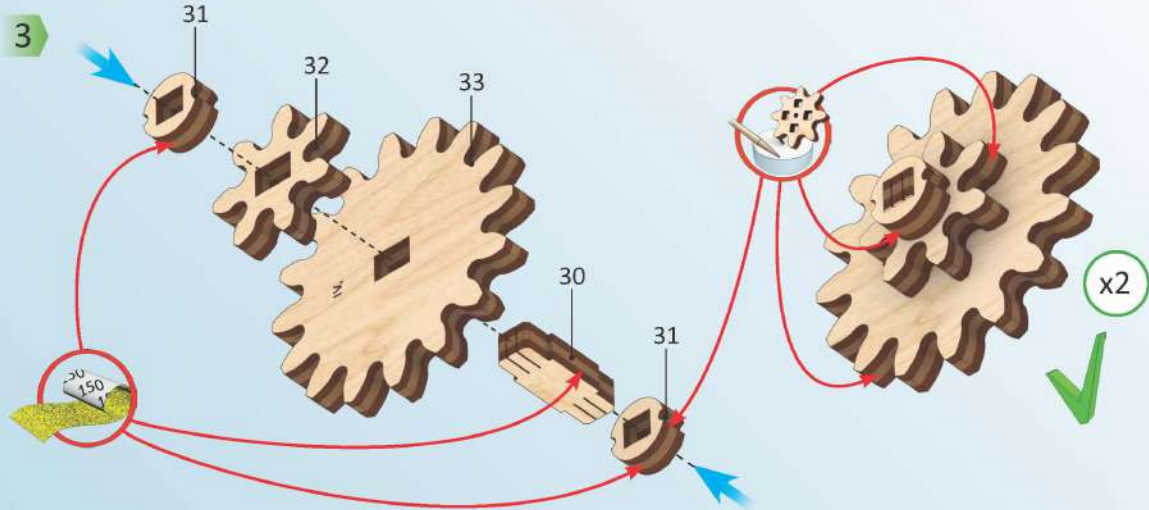
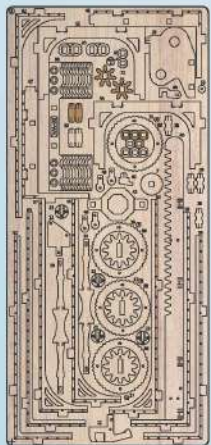
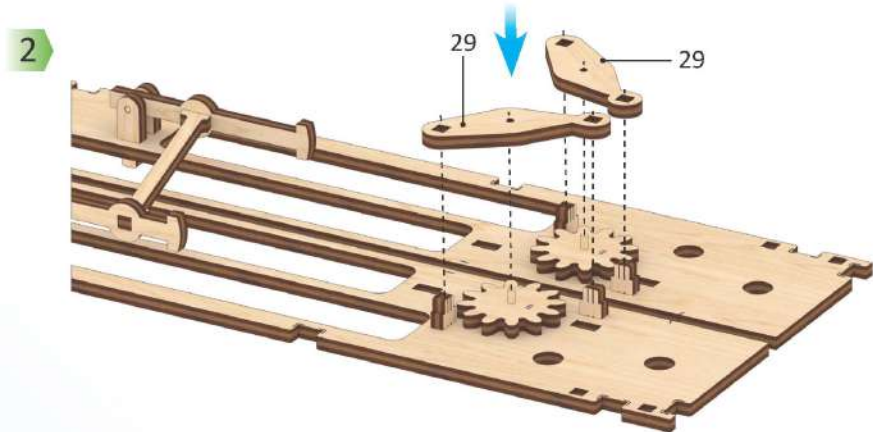
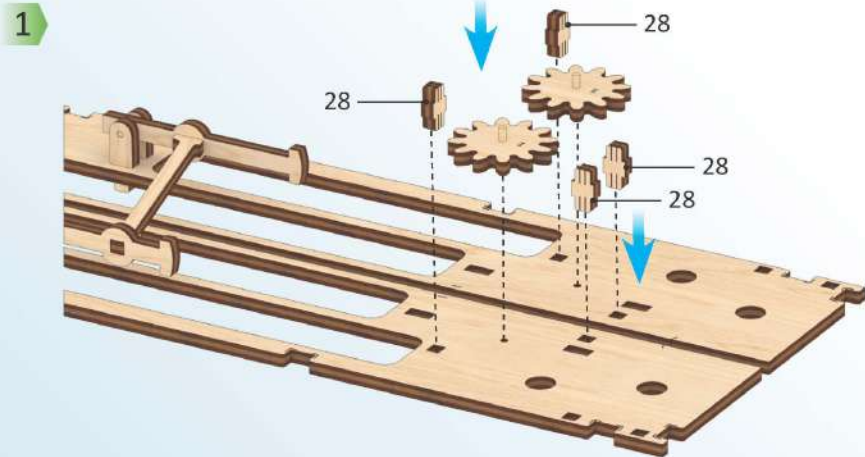
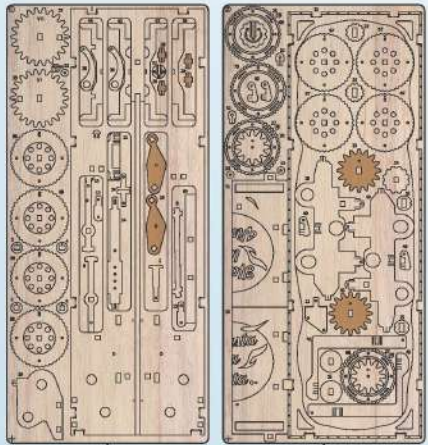

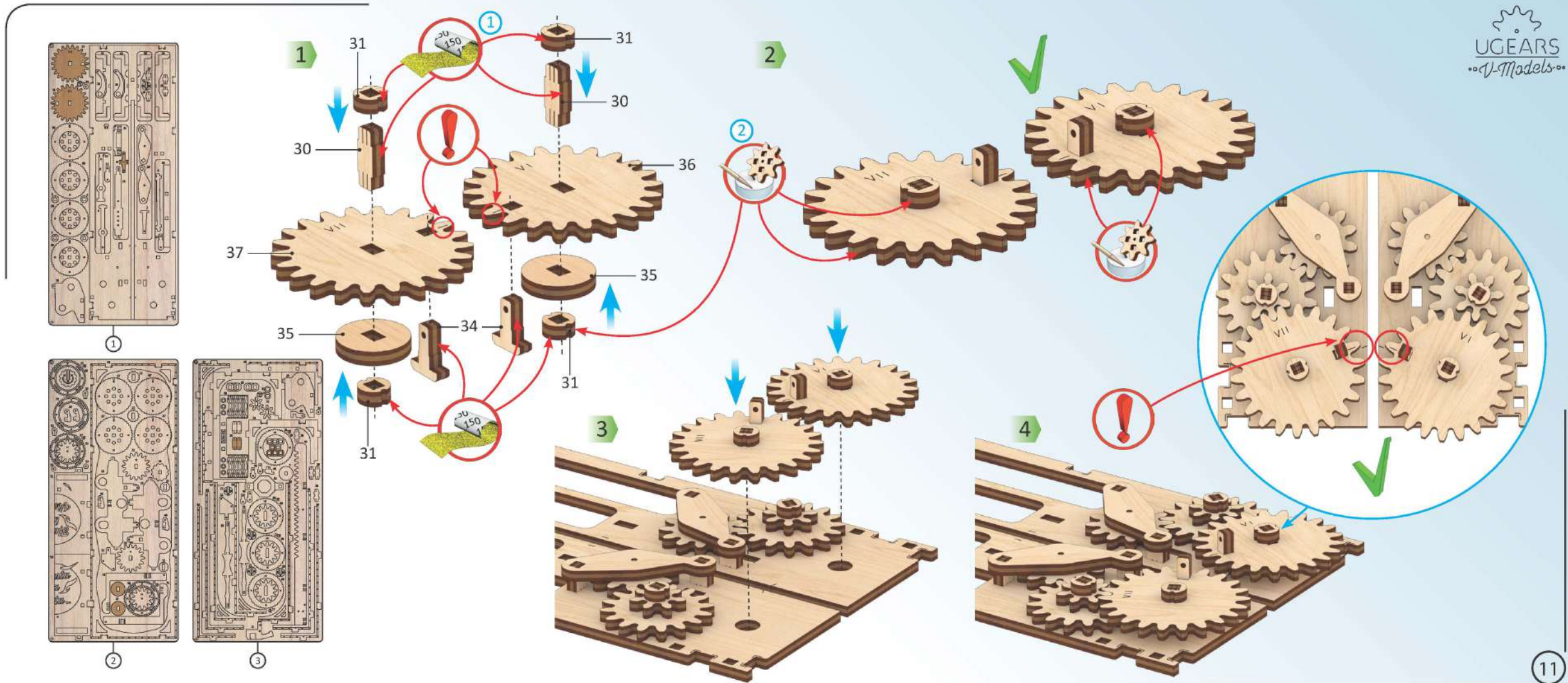

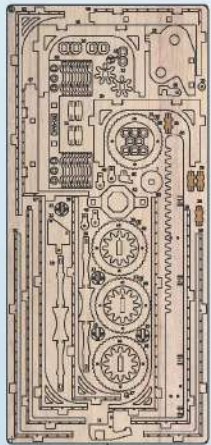

3

1

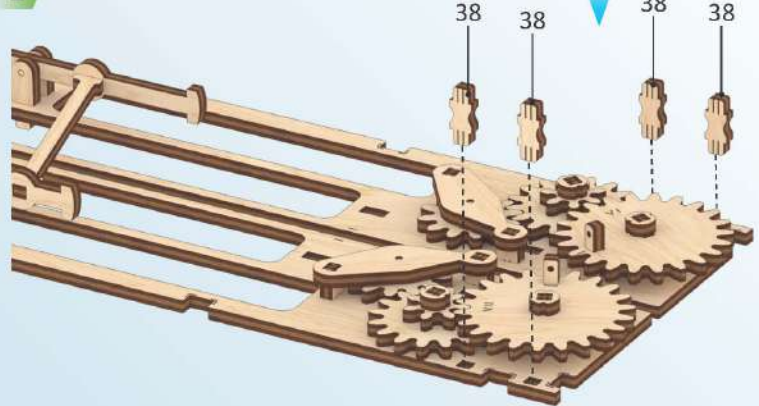

2

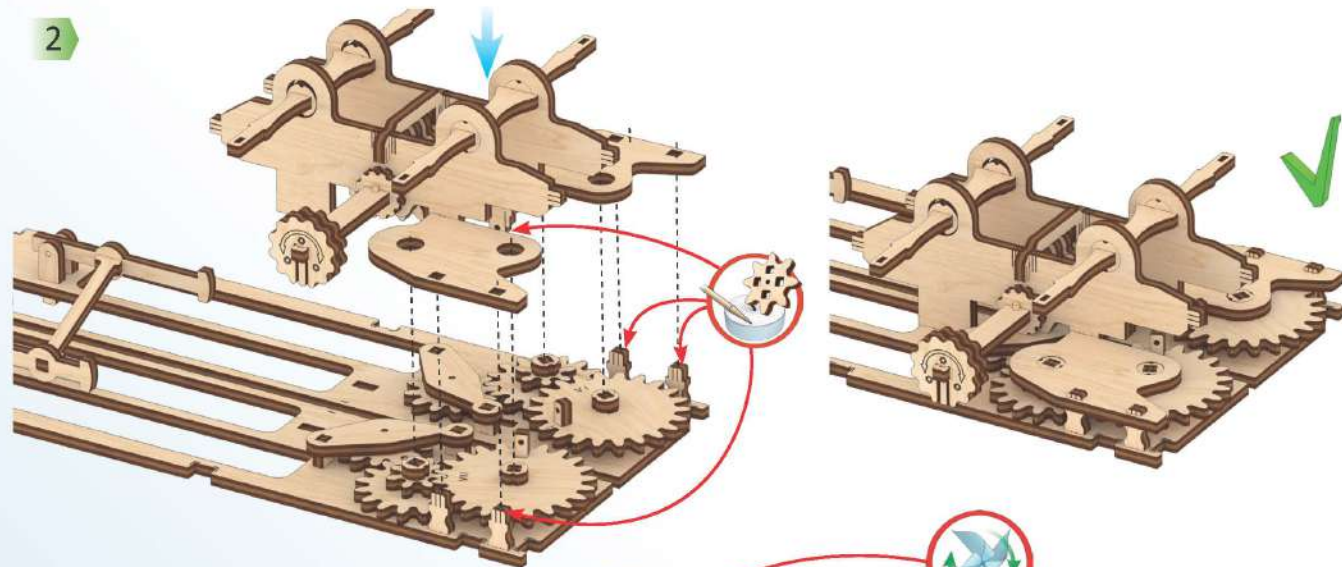

3

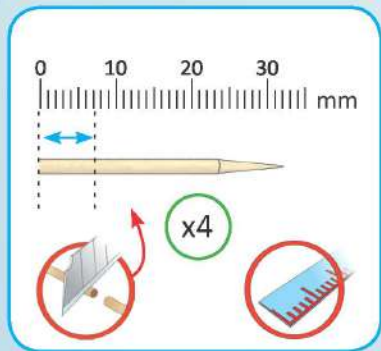

4

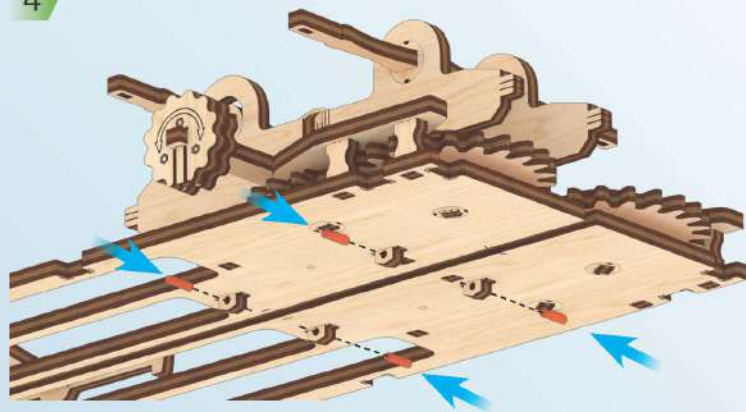

5

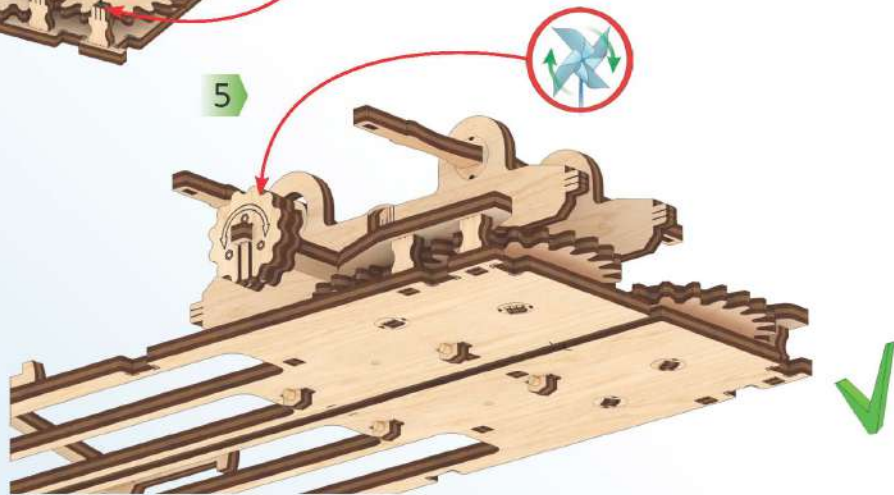

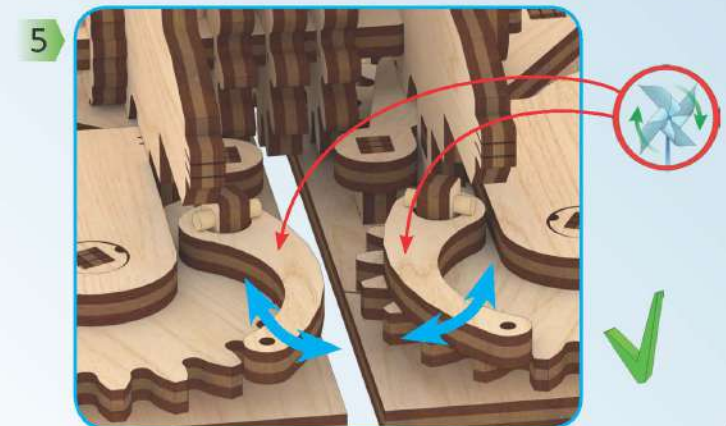
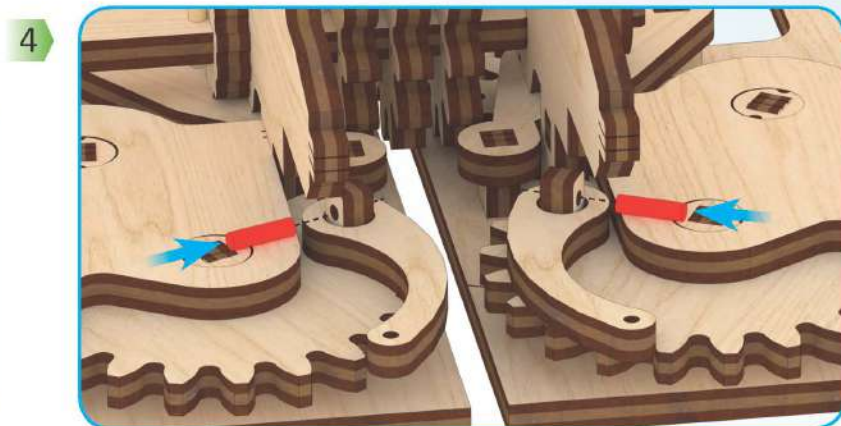
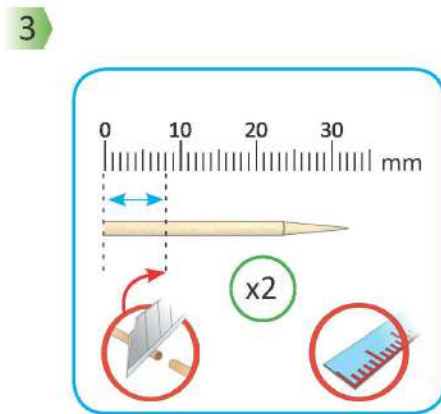
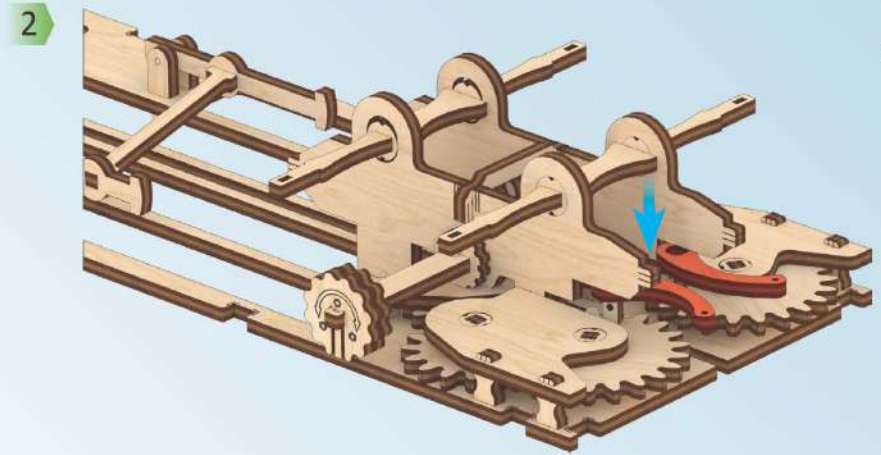
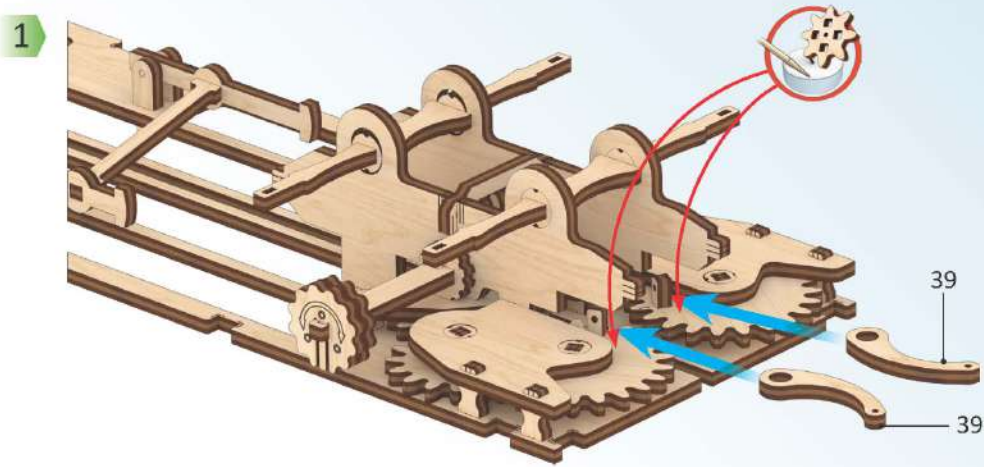
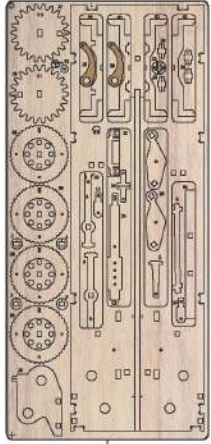

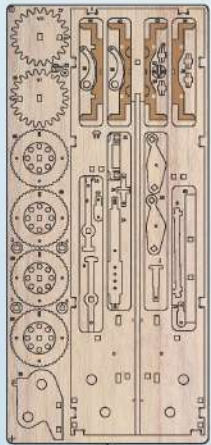

1

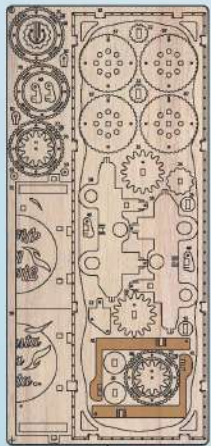

2

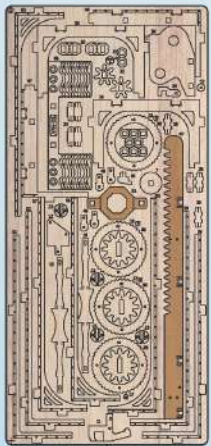

3

1

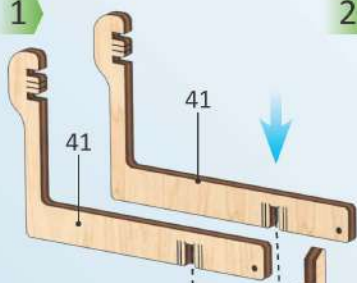

2

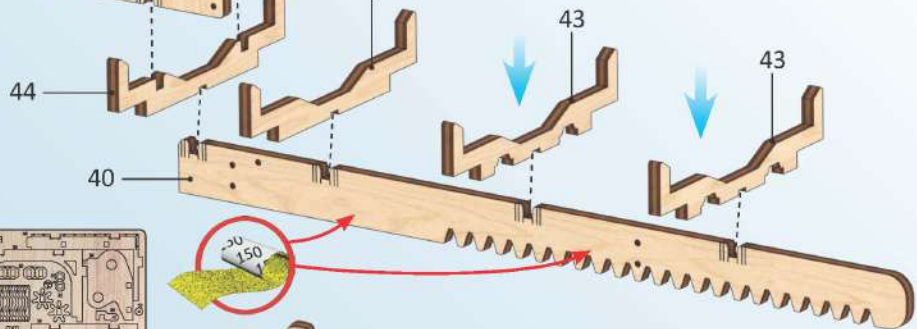
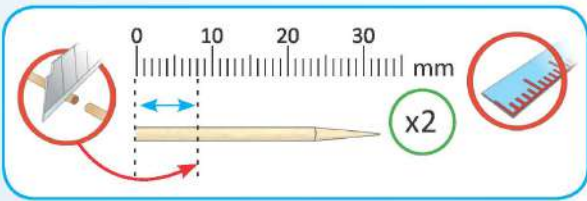

4

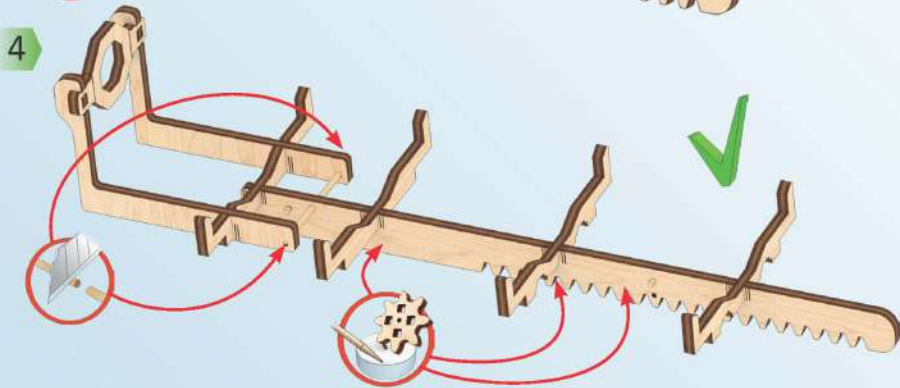

3

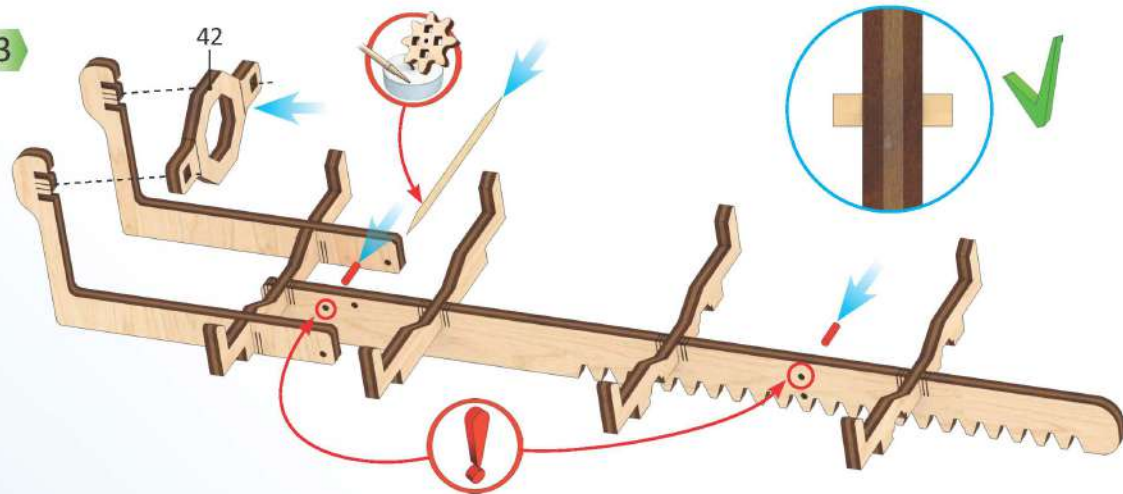

5

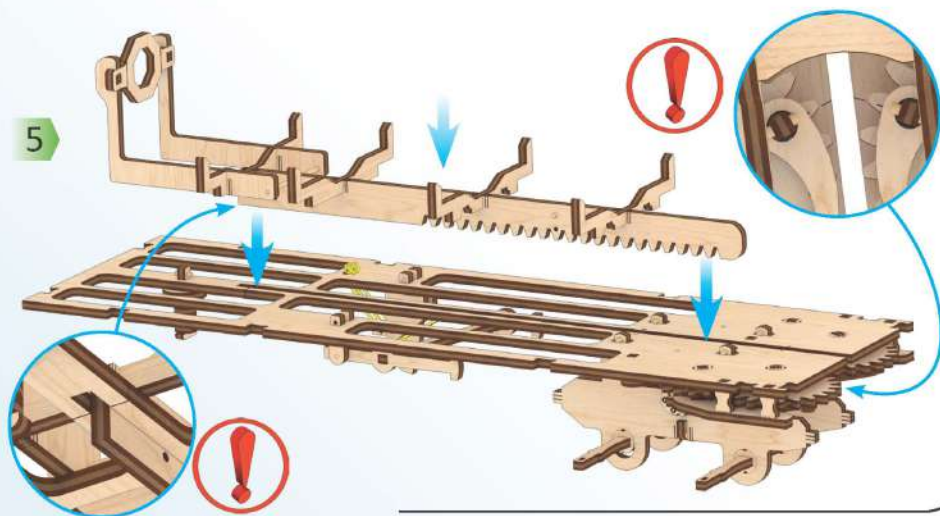

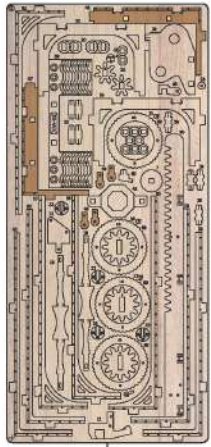

3

1

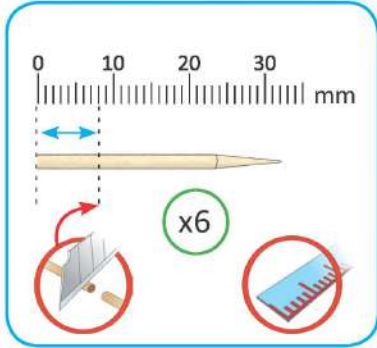

2

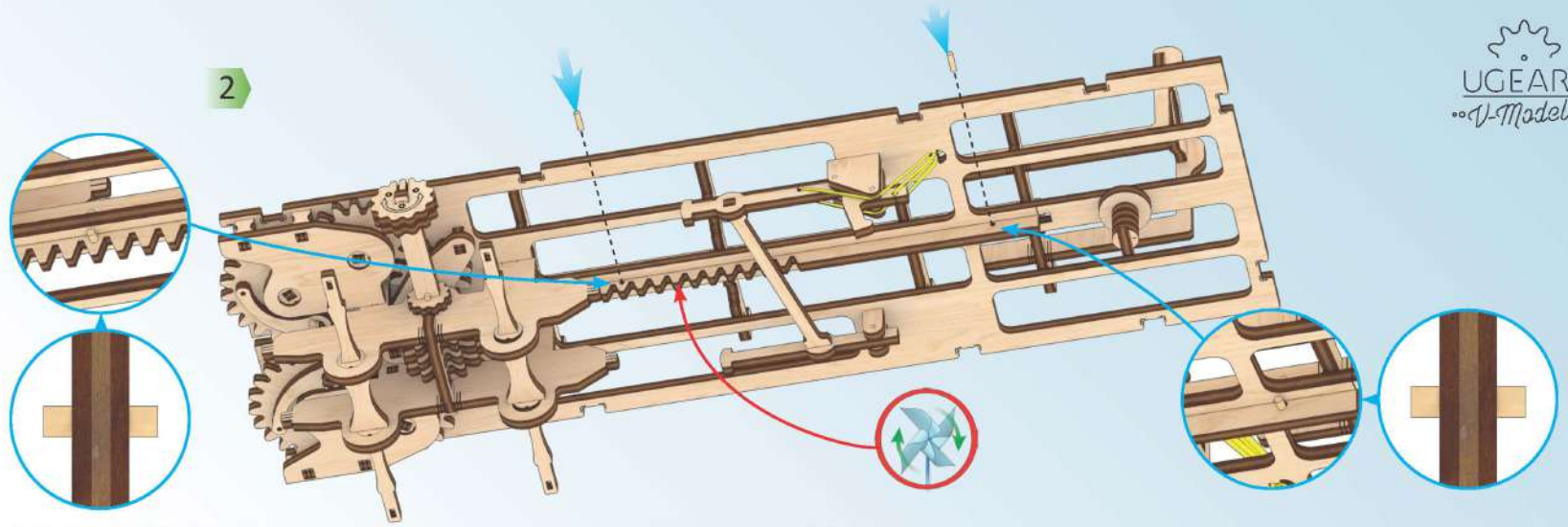

1

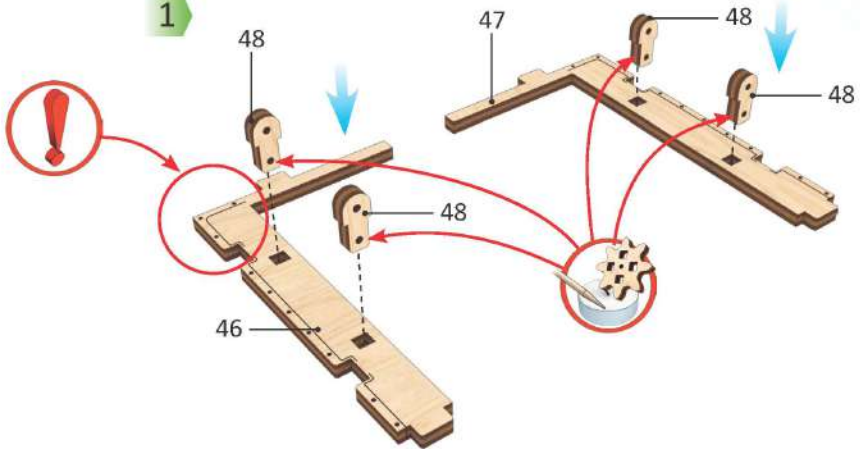

2

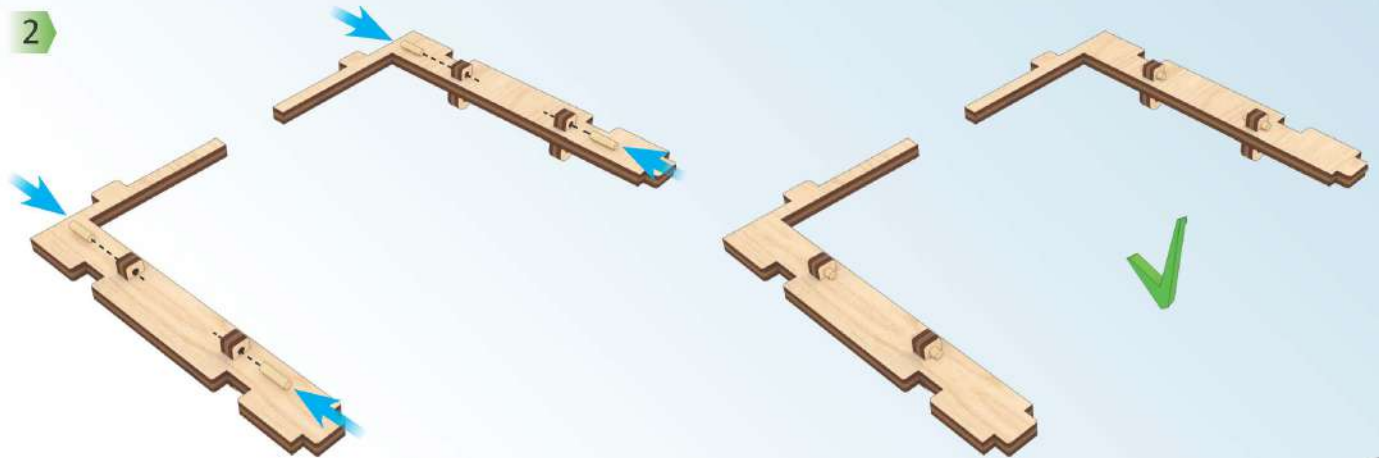

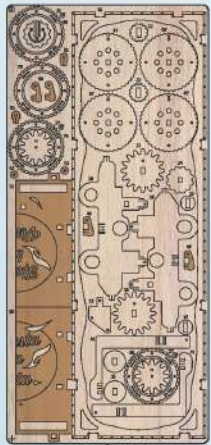

2

1

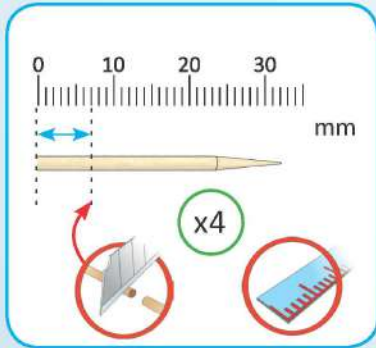

2

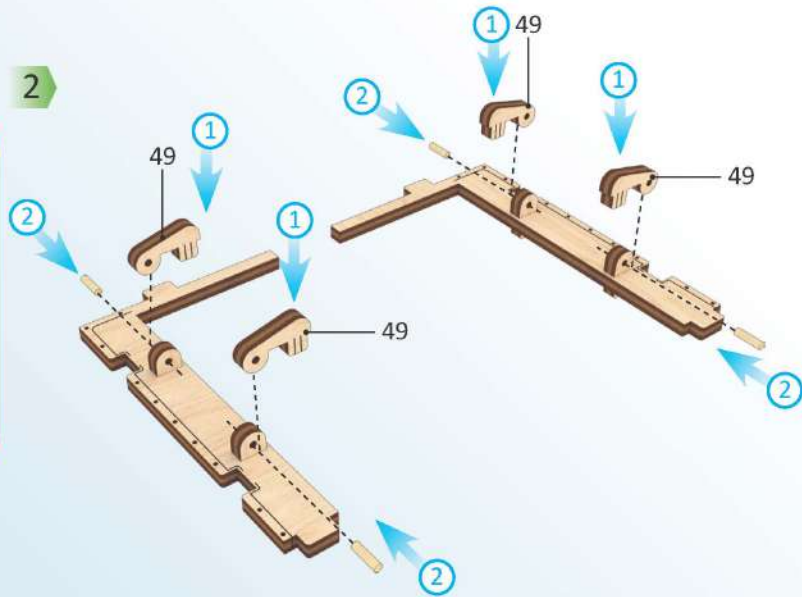

3

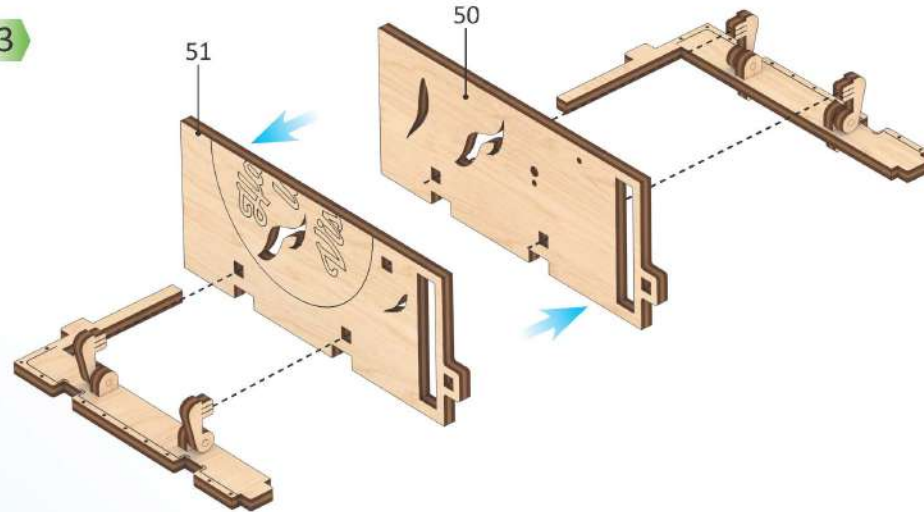

4

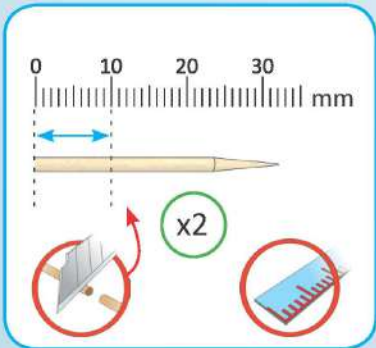

5

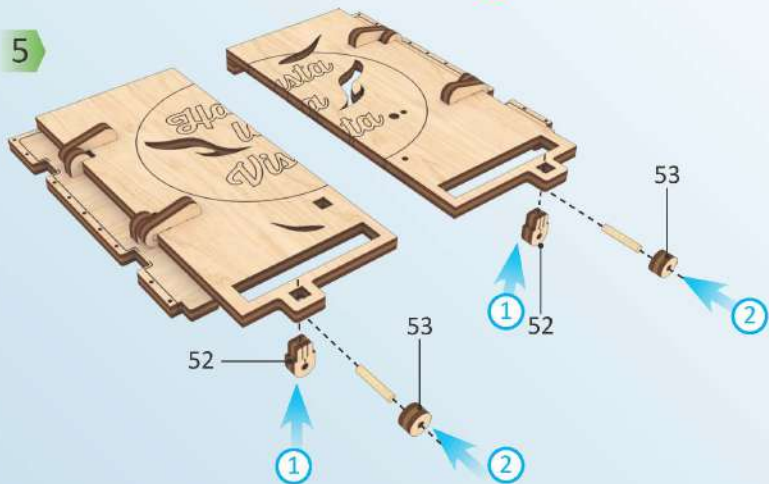

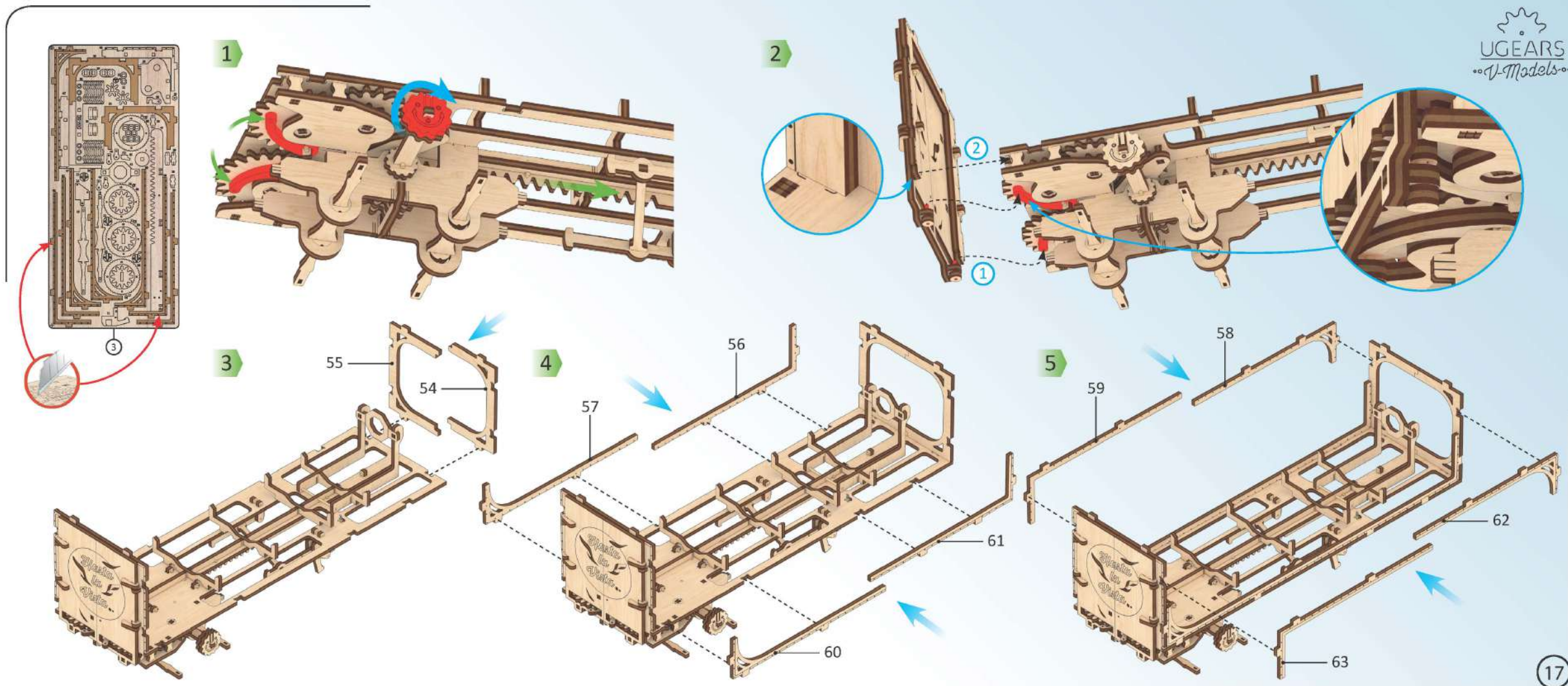

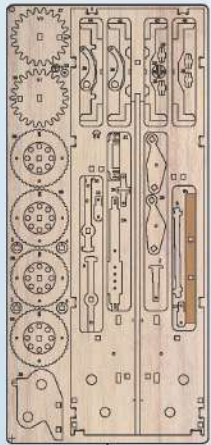

1

1

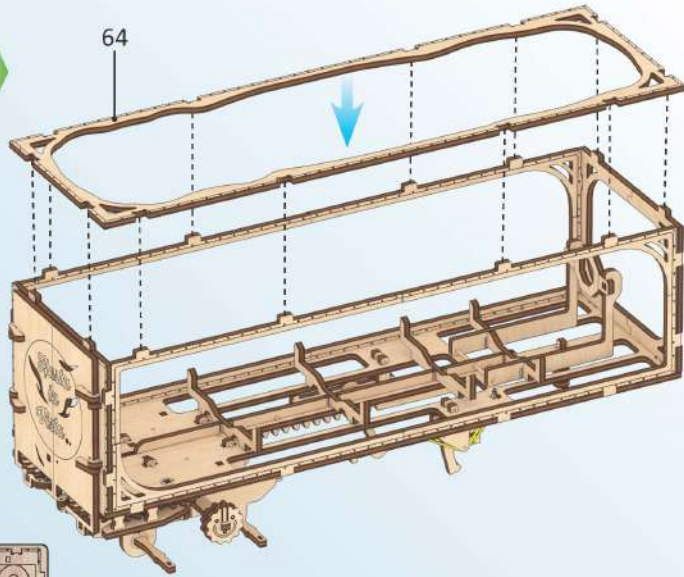

64

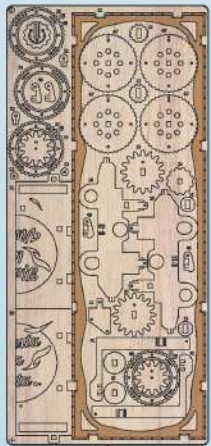

2

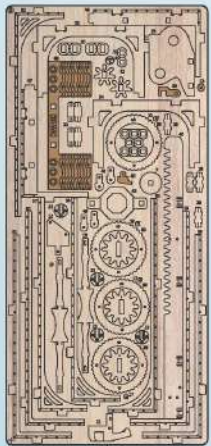

3

3

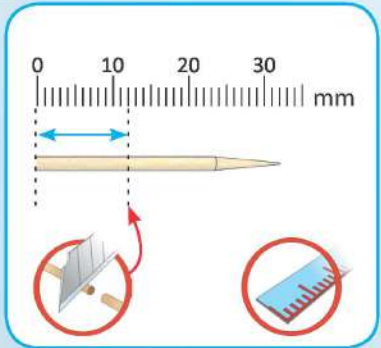

4

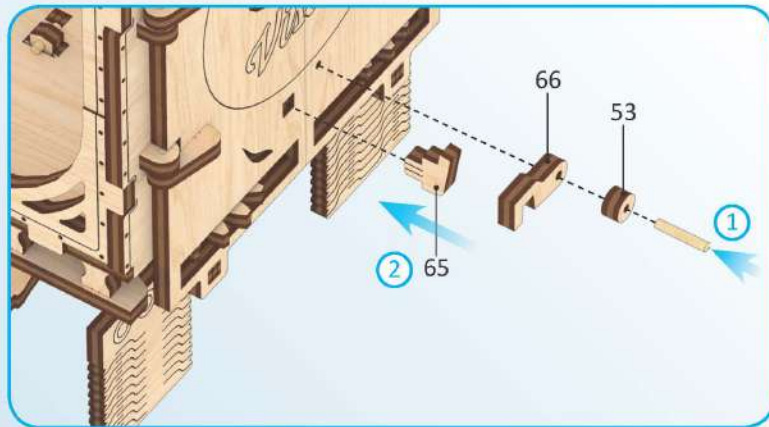

66

53

65

1

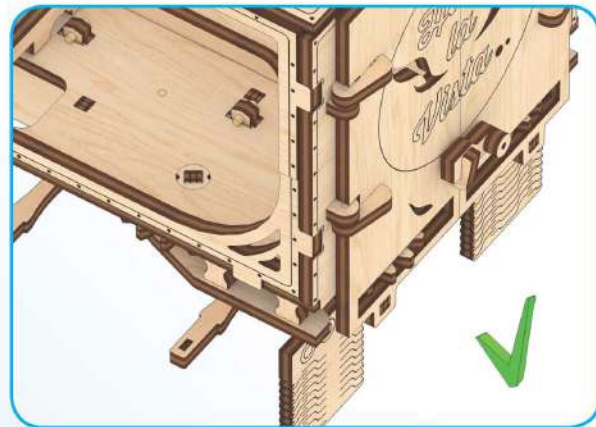

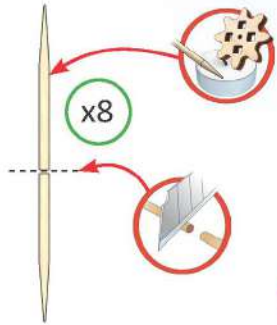
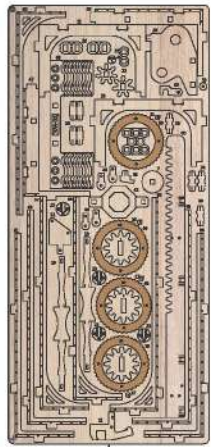
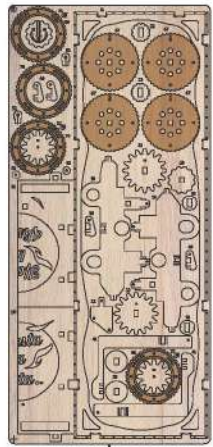
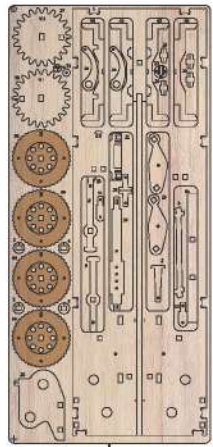

1

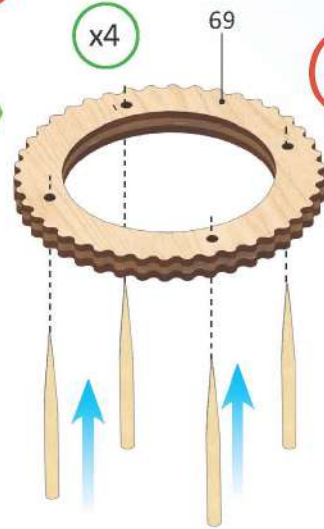

2

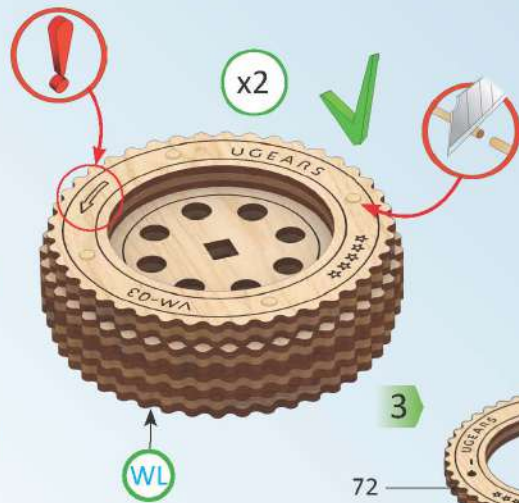
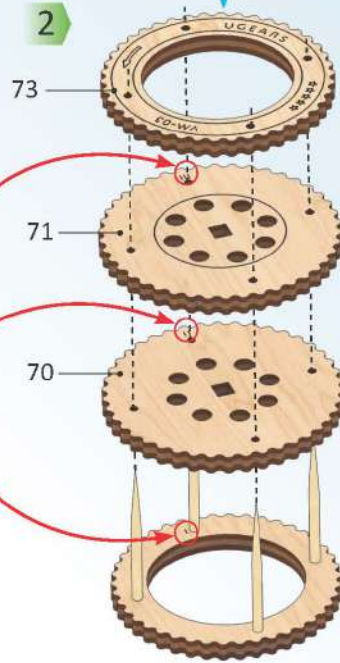

3

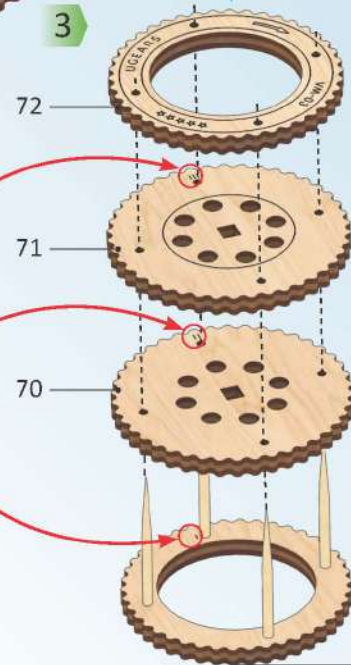

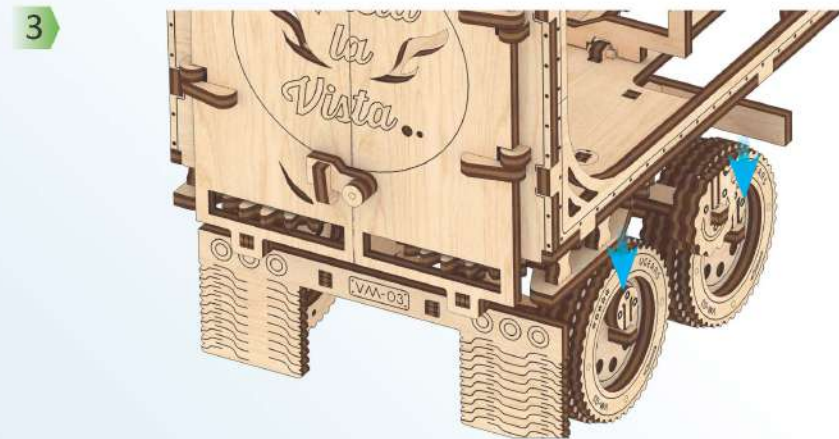
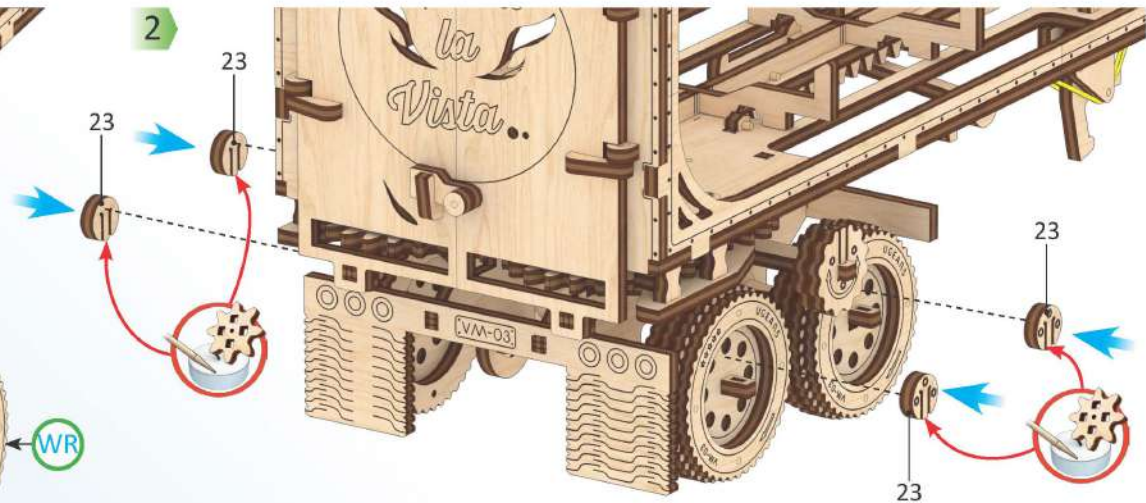
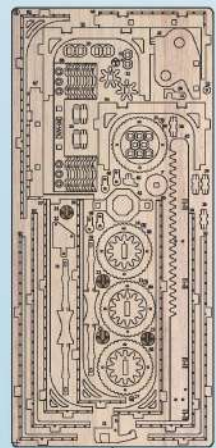
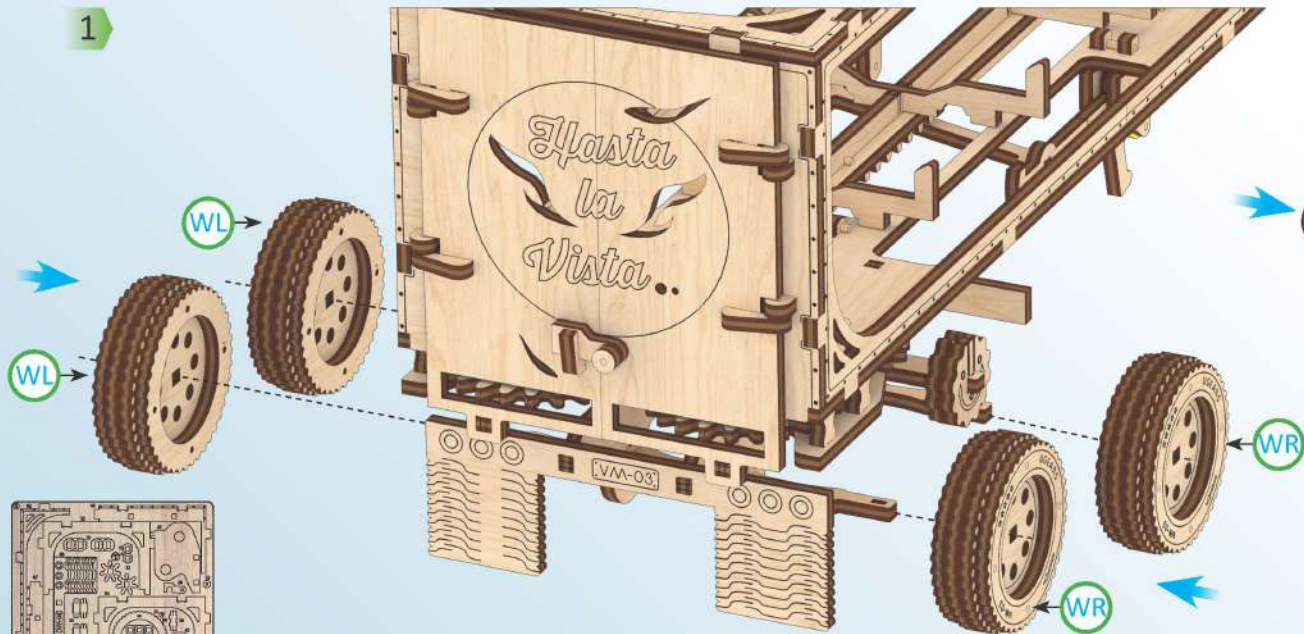

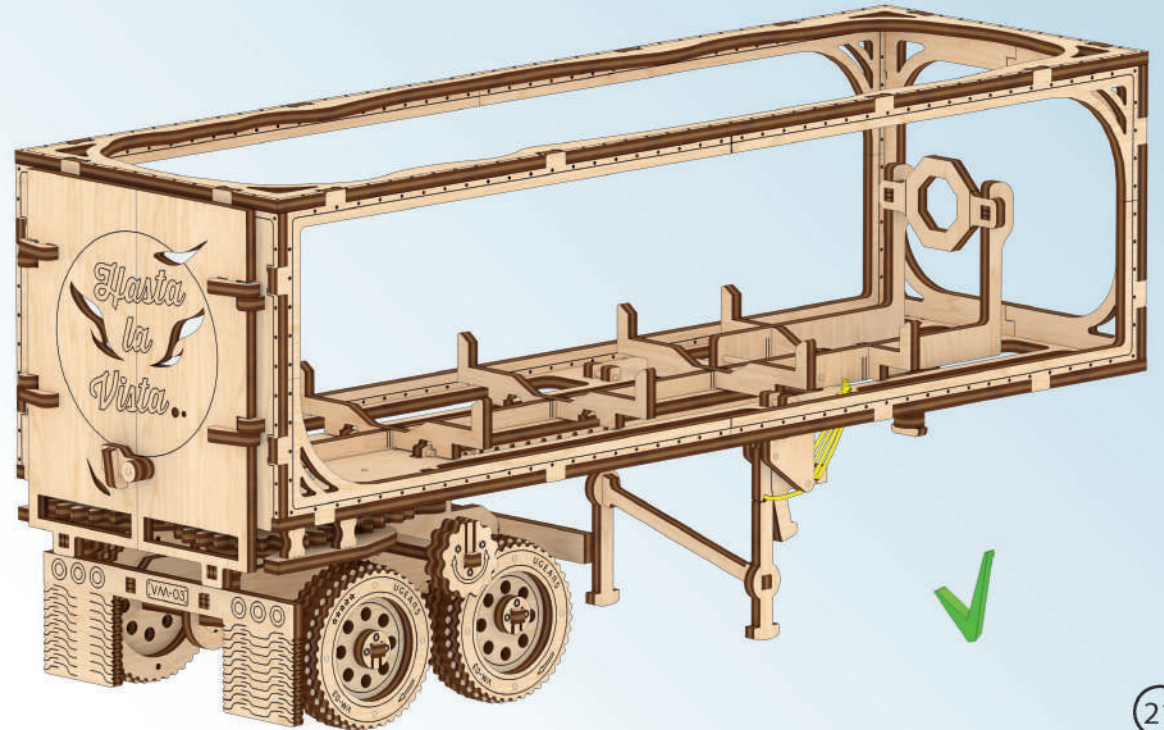
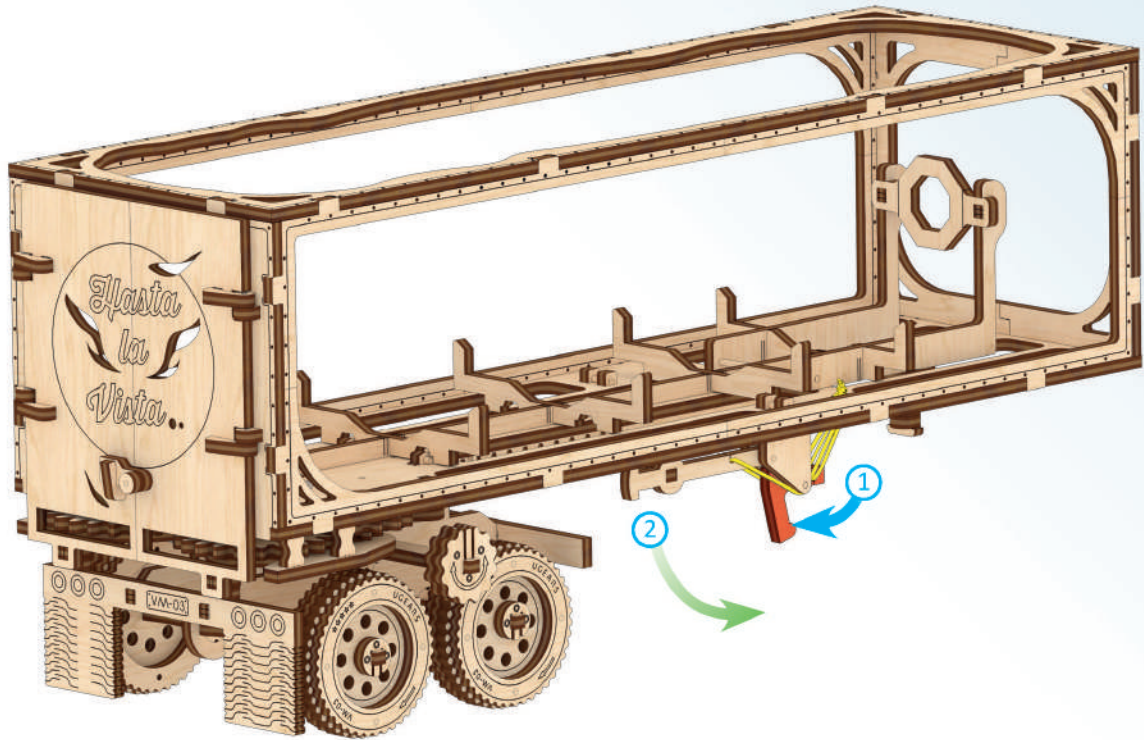

1

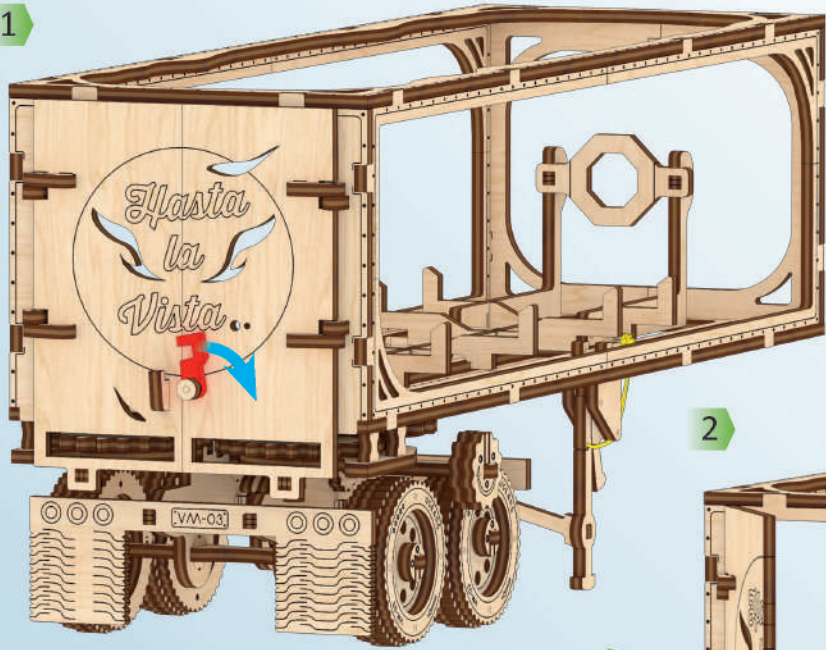

2

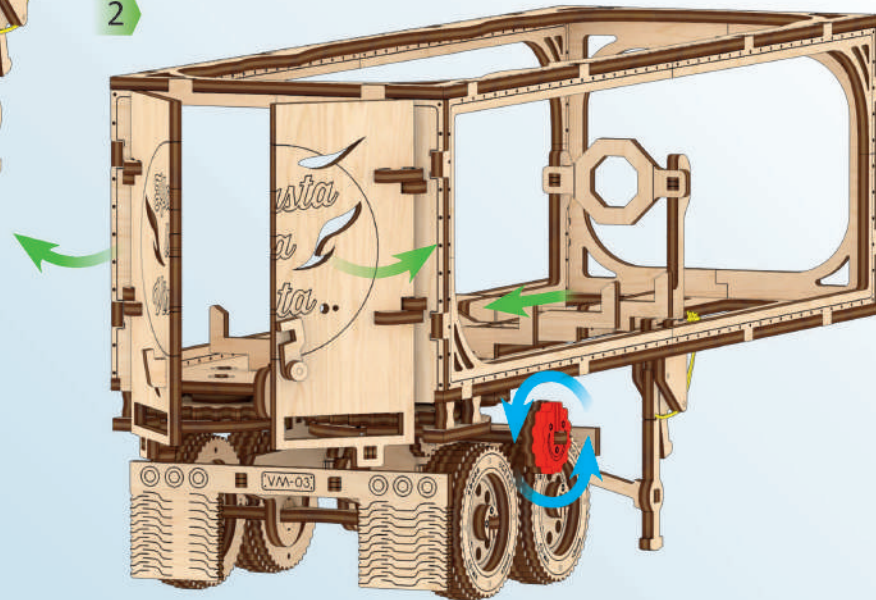

3

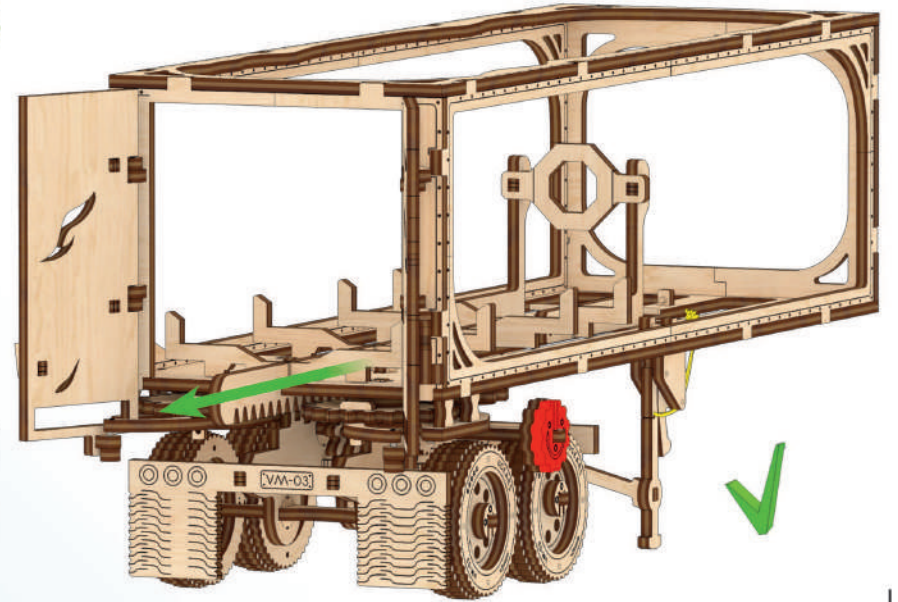

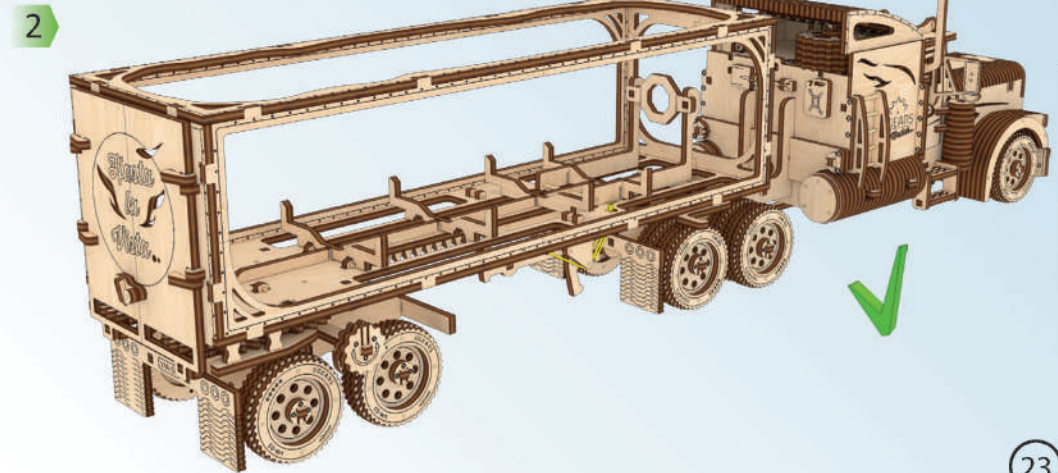
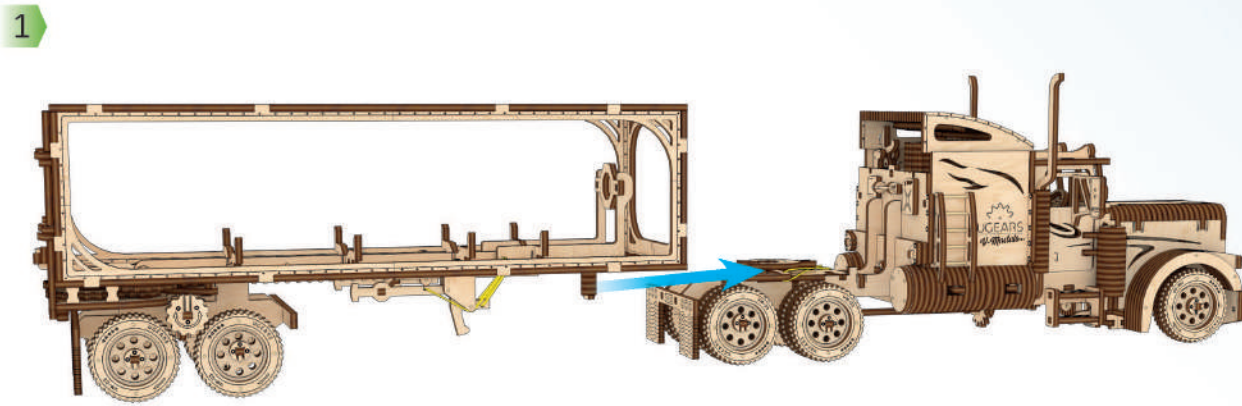
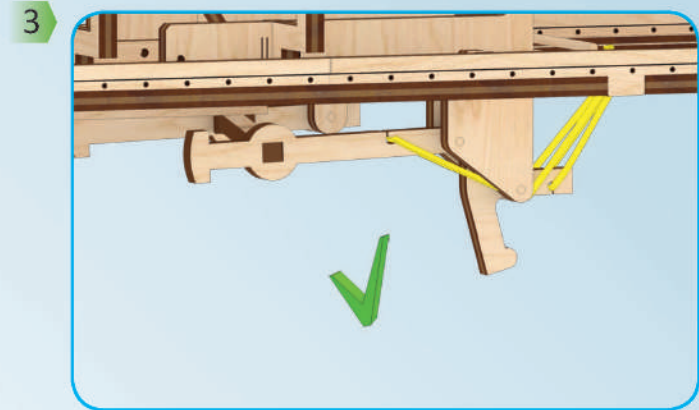
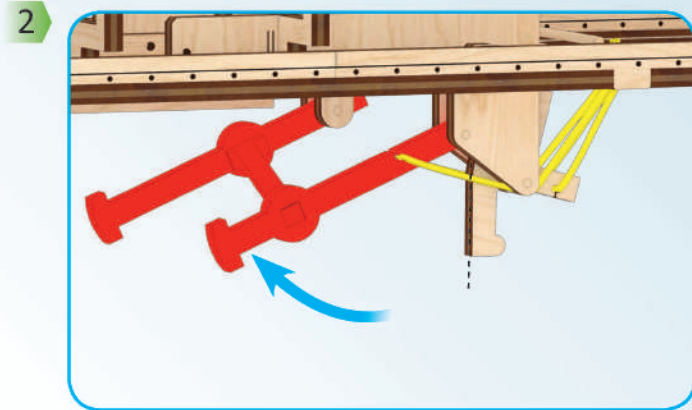
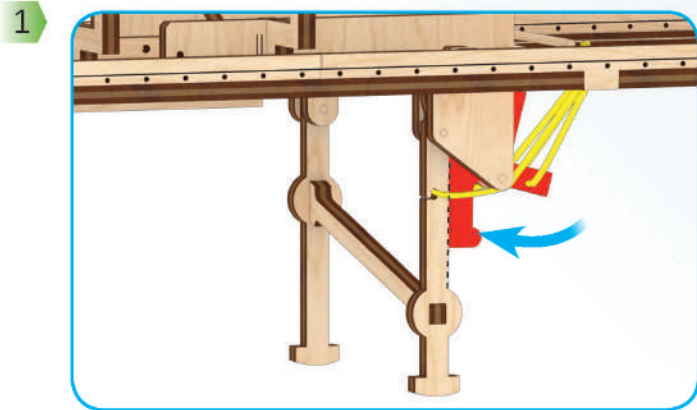

Assemble Me. Hook Up & Load Me

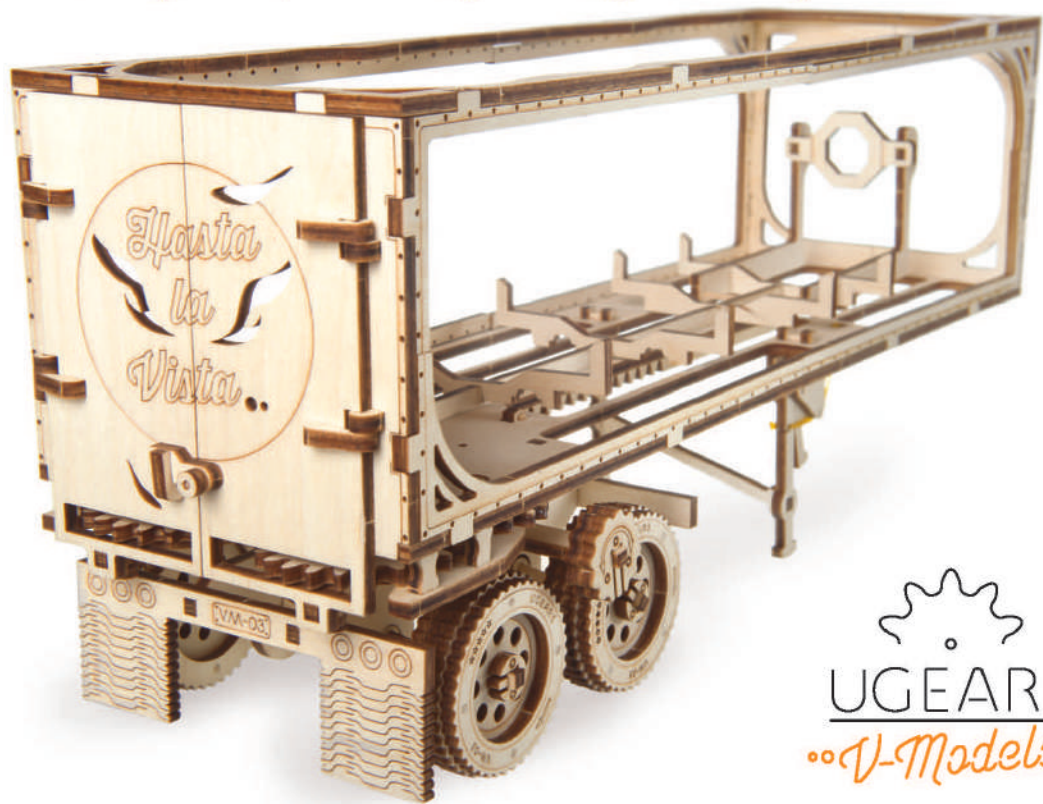

Watch the VIDEO

UGEAR.S®
U-Models

ENG Thanks for following along on this journey with us. UKR Дякуємо, що ви пройшли цей шлях з нами. DEU Vielen Dank, dass Sie diesen Weg mit uns gegangen sind. FRA Merci denous avoir accompagnés tout au long de ces étapes. POL Dziękujemy, że razem z nami pokonałeś tę drogę! SPA Gracias por haber recorrido el camino con nosotros. ITA Grazie per aver fatto uesto percorso con noi. TUR Bizimle bu yolu geçtiğiniz için teşekkür ederiz. RUS Спасибо, что вы прошли этот путь с нами. KOR UGEARS와 함께해 주셔서 감사합니다. CHI 感谢您参与有趣的模型装配过程。

ugearsmodels.com

